

Cable-Extension Displacement Sensor



FEATURES

- Full-scale ranges from 5 to 50 inches
- Rugged, low profile design
- Switch-selectable potentiometer and Wheatstone bridge output circuits
- Standard RJ-45 electrical connections.
- Compatible with all Vishay Micro-Measurements strain gage and high-level-signal instrumentation.
- Easy to install and use.

DESCRIPTION

The Vishay Micro-Measurements Cable-Extension Displacement Sensor provides a voltage signal linearly proportional to the extension of a retractable stainless steel cable. Used for indicating the displacement of the test structure, member or part to which the cable is attached, installation is quick and easy. Simply attach the base of the sensors to a

reference surface, the cable to the component being displaced, and the electrical leads to any instrument accepting strain-gage or high-level signal inputs. With the certified calibration data and wiring instructions provided with each sensor, you will be making displacement measurements in minutes.

SPECIFICATIONS

MODEL		CDS-05	CDS-010	CDS-20	CDS-30	CDS-40	CDS-50
Measurement Range	in [mm]	5 [127 mm]	10 [254 mm]	20 [508 mm]	30 [762 mm]	40 [1016 mm]	50 [1270 mm]
Accuracy	% FS	0.25	0.15	0.10	0.10	0.10	0.10
Resolution		Analog (Effectively infinite, limited only by instrumentation)					
Repeatability		Greater of ± 0.001 in [± 0.025 mm] or 0.02% FS					
Cable Retraction Force (min)	oz. [N]	3.5 [1.0]	8.4 [2.3]	8.4 [2.3]	6.3 [1.8]	4.2 [1.1]	3.5 [1.0]
Cable Extension Force (max)	oz. [N]	6.5 [1.8]	15.6 [4.3]	15.6 [4.3]	11.7 [3.3]	7.8 [2.2]	6.5 [1.8]
Cable Acceleration	g	3	11	11	5	4	3
Vibration	g, Hz	Up to 10, 0 - 2000					
Shock	g, mS	100, 0.1					
Sensor		Plastic-hybrid precision potentiometer					
Resistance	ohms	500					
Maximum Supply Voltage - Potentiometer	V	30					
Maximum Supply Voltage - Bridge	V	30					
Output - Bridge	mV/V FS	3.0 typical					
Case		Powder-painted aluminum alloy					
Cable		Nylon-coated stainless steel, 0.019 in [0.48 mm] diameter					
Electrical Connector		RJ-45 receptacle					
Weight	lb [kg]	2 [1] typ.					
Operating Temperature	$^{\circ}$ F [$^{\circ}$ C]	- 40 to + 200 [- 40 to 93]					
TC of Sensor	ppm/ $^{\circ}$ F [ppm/ $^{\circ}$ C]	88 [157]					
Humidity	% RH	100 at 90 $^{\circ}$ F [32 $^{\circ}$ C]					

Cable-Extension Displacement Sensor

DIMENSIONS

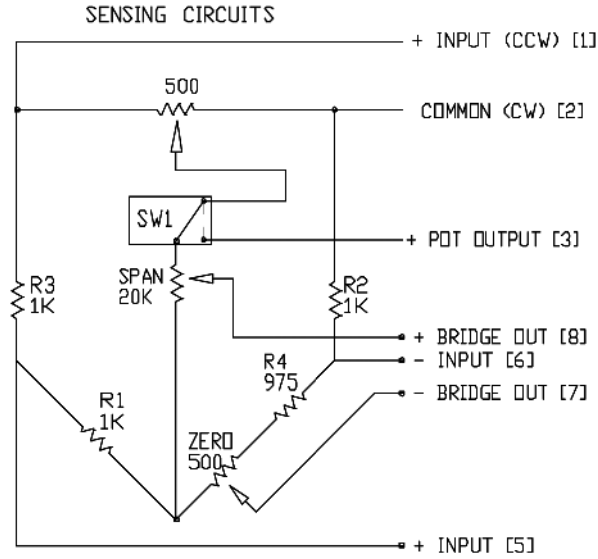

MEASUREMENT RANGE (INCHES)	5	10	20	30	40	50
DIMENSION *A*	0.16	0.65	0.65	0.43	0.35	0.16

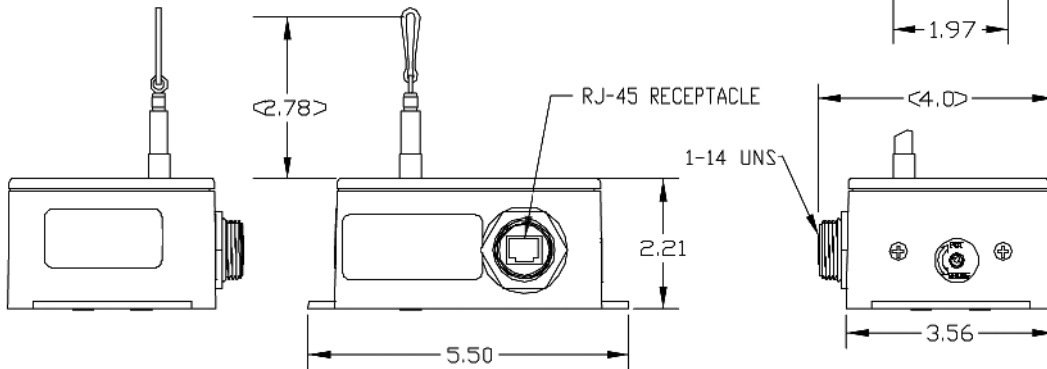
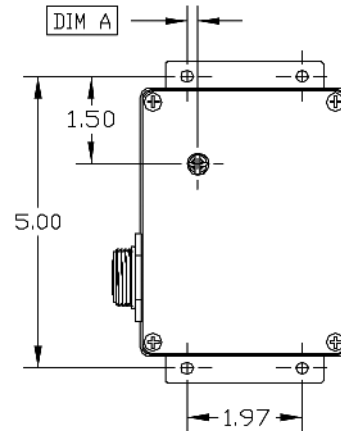
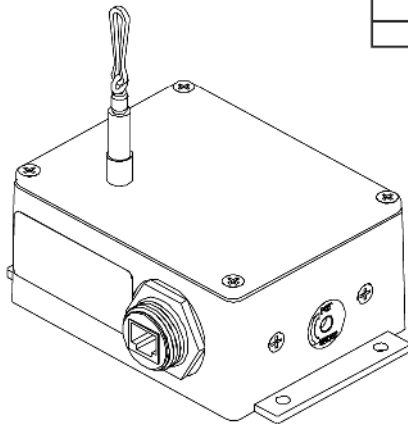



Disclaimer

All product specifications and data are subject to change without notice.

Vishay Intertechnology, Inc., its affiliates, agents, and employees, and all persons acting on its or their behalf (collectively, "Vishay"), disclaim any and all liability for any errors, inaccuracies or incompleteness contained herein or in any other disclosure relating to any product.

Vishay disclaims any and all liability arising out of the use or application of any product described herein or of any information provided herein to the maximum extent permitted by law. The product specifications do not expand or otherwise modify Vishay's terms and conditions of purchase, including but not limited to the warranty expressed therein, which apply to these products.

No license, express or implied, by estoppel or otherwise, to any intellectual property rights is granted by this document or by any conduct of Vishay.

The products shown herein are not designed for use in medical, life-saving, or life-sustaining applications unless otherwise expressly indicated. Customers using or selling Vishay products not expressly indicated for use in such applications do so entirely at their own risk and agree to fully indemnify Vishay for any damages arising or resulting from such use or sale. Please contact authorized Vishay personnel to obtain written terms and conditions regarding products designed for such applications.

Product names and markings noted herein may be trademarks of their respective owners.