

Carbon Film, Cylindrical, Fusible Resistors

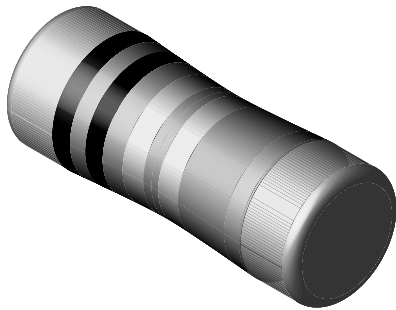

FEATURES

- Fusible resistor for constant voltage designed for overload protection
- Specially spiralled to provide the fusible function
- Flame retardant coating
- Used in battery chargers, TV-sets, cordless phones, PC/CPU-cooler
- Pure tin termination on nickel barrier, plated on press fit steel caps
- Compatible with lead (Pb)-free and lead containing soldering processes
- Lead (Pb)-free and RoHS compliant



STANDARD ELECTRICAL SPECIFICATIONS					
MODEL	POWER RATING ¹⁾ P ₇₀ W	TEMPERATURE COEFFICIENT ppm/K	TOLERANCE %	RESISTANCE RANGE Ω	E-SERIES
LCM0207SI	0.25	+ 300/- 250	± 5	R22 - 1K0	24

Note

1. Permissible dissipation depends on the maximum temperature at the solder point, the component placement density and the substrate material.
- Marking: According to IEC 60062; see also datasheet "surface mount resistor marking" (document number: 20020)

TECHNICAL SPECIFICATIONS		
PARAMETER	UNIT	LCM0207SI
Rated Dissipation at 70 °C	W	0.25
Minimum Overload to Fuse	W	> 1R0 < 1R0
Time to Fuse (max)	s	15
Thermal Resistance ²⁾	K/W	≤ 220
Voltage Coefficient	V ⁻¹	≥ 10 ⁷
Category Temperature Range	°C	- 55 to + 125
Failure Rate	10 ⁻⁹ /h	< 30
Weight/1000 pcs	g	71

Note

2. Based on measurements on test board acc. to EN 140400.

PART NUMBER AND PRODUCT DESCRIPTION³⁾

PART NUMBER⁴⁾: LCM02070B01008JBP

L	C	M	0	2	0	7	B	0	1	0	0	8	J	B	P		
---	---	---	---	---	---	---	---	---	---	---	---	---	---	---	---	--	--

MODEL/SIZE LCM0207	SPECIAL CHARACTER B = SI Fusible	TC 0 = neutral see data sheet for TC value	VALUE 3 digit value 1 digit multiplier Multiplier 7 = *10 ⁻³ 0 = *10 ⁰ 8 = *10 ⁻² 1 = *10 ¹ 9 = *10 ⁻¹	TOLERANCE J = ± 5 %	PACKING⁵⁾ BP BS	SPECIAL up to 2 digits 00 = standard
------------------------------	--	---	---	-------------------------------	---	---

PRODUCT DESCRIPTION: LCM0207SI 1R0 5% BP

LCM0207SI	1R0	5 %	BP
MODEL	RESISTANCE VALUE	TOLERANCE	PACKING ⁵⁾
LCM0207SI	1R0 = 1 Ω R22 = 0.22 Ω	± 5 %	BP BS

Note

3. Products can be ordered using either the PRODUCT DESCRIPTION or the PART NUMBER.
4. The PART NUMBER is shown to facilitate the introduction of a unified part numbering system. Currently, this PART NUMBER is applicable in the Americas only.
5. Please refer to table PACKING, see below.

Dimensions

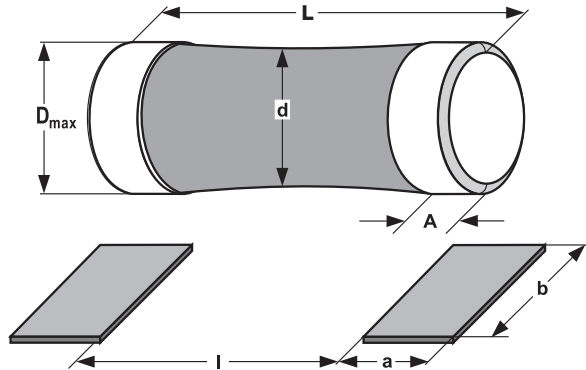

MODEL	DIMENSIONS [in millimeters]				
	D _{max}	d*	L	A _{max}	A _{min}
LCM0207SI	2.2	D - 0.4	5.8- 0.3	1.2	0.6

* d measured in the middle of the resistor

MODEL	SOLDER PAD DIMENSIONS [in millimeters]					
	REFLOW SOLDERING			WAVE SOLDERING		
	a	b	l	a	b	l
LCM0207SI	1.8	2.5	2.9	2.4	2.5	2.8

PACKING			
MODEL	BLISTER TAPE ON REEL ACC. IEC 60286-3		
	DIAMETER	PIECES/REEL	CODE
LCM0207SI	180 mm/7"	1500	BP
	330 mm/13"	7500	BS

Further information about PACKING see also datasheet "surface mount resistor packing" (document number: 20014).

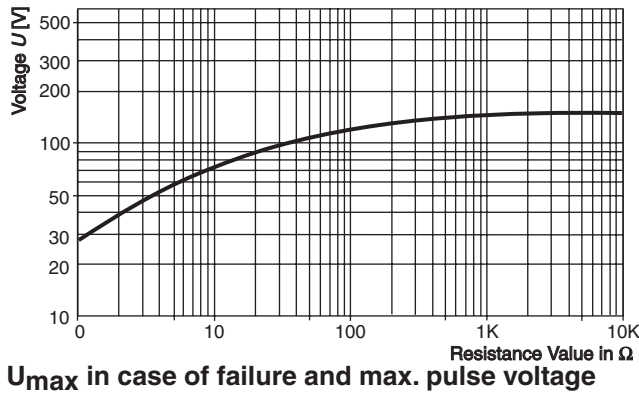
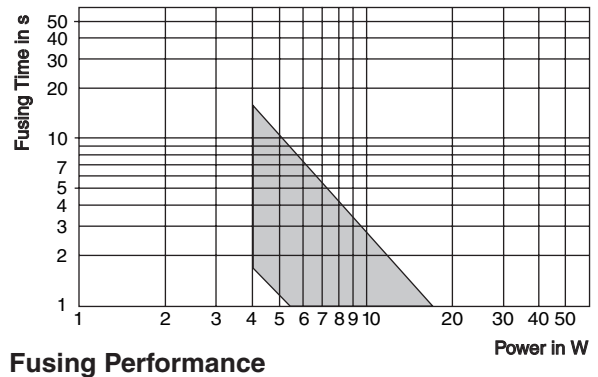
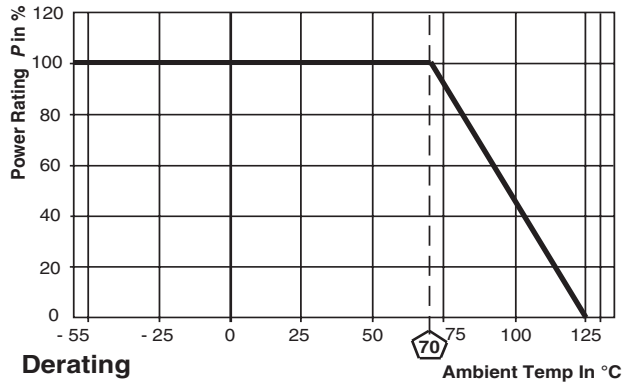



PERFORMANCE		
TEST	CONDITIONS OF TEST	REQUIREMENTS
Endurance Test at 70 °C IEC 60115-1, 4.25.1	1000 hours at 70 °C, 1.5 hours "ON", 0.5 hours "OFF"	≤ 2 %
Endurance at UCT IEC 60115-1, 4.25.3	1000 hours at 125 °C without load	≤ 2 %
Thermal Shock IEC 60115-1, 4.19 and IEC 60068-2-14	Rapid change between upper and lower category temperature, 5 cycles	≤ 0.5 %
Damp Heat Steady State IEC 60115-1, 4.24 and IEC 60068-2-78	56 days at 40 °C and 93 % relative humidity	≤ 2 %
Resistance to Soldering Heat IEC 60115-1, 4.18 and IEC 60068-2-58	10 seconds at 260 °C solder bath temperature	≤ 0.25 %

SOLDERING INFORMATION
<ul style="list-style-type: none"> • For reflow soldering only • Board has to be thoroughly cleaned after soldering. All flux materials must be completely removed

APPLICABLE SPECIFICATION
<ul style="list-style-type: none"> • EN 60115-1



Disclaimer

All product specifications and data are subject to change without notice.

Vishay Intertechnology, Inc., its affiliates, agents, and employees, and all persons acting on its or their behalf (collectively, "Vishay"), disclaim any and all liability for any errors, inaccuracies or incompleteness contained herein or in any other disclosure relating to any product.

Vishay disclaims any and all liability arising out of the use or application of any product described herein or of any information provided herein to the maximum extent permitted by law. The product specifications do not expand or otherwise modify Vishay's terms and conditions of purchase, including but not limited to the warranty expressed therein, which apply to these products.

No license, express or implied, by estoppel or otherwise, to any intellectual property rights is granted by this document or by any conduct of Vishay.

The products shown herein are not designed for use in medical, life-saving, or life-sustaining applications unless otherwise expressly indicated. Customers using or selling Vishay products not expressly indicated for use in such applications do so entirely at their own risk and agree to fully indemnify Vishay for any damages arising or resulting from such use or sale. Please contact authorized Vishay personnel to obtain written terms and conditions regarding products designed for such applications.

Product names and markings noted herein may be trademarks of their respective owners.