



Ceramic Disc, RFI, and Safety Capacitors

In accordance with IEC recommendations ceramic capacitors are subdivided into two classes:

- CERAMIC CLASS 1 or low-K capacitors are mainly manufactured of titanium dioxide or magnesium silicate
- CERAMIC CLASS 2 or high-K capacitors contain mostly alkaline titanate

MAIN FEATURES		
	CLASS 1	CLASS 2
Application	For temperature compensation of frequency discriminating circuits and filters, coupling and decoupling in high-frequency circuits where low losses and narrow capacitance tolerances are demanded. As RFI and safety capacitors.	As coupling and decoupling capacitors for such application where higher losses and a reduced capacitance stability are required. As RFI and safety capacitors.
Properties Temperature Dependence Capacitance	High stability of capacitance. Low dissipation factor up to higher frequencies. Defined temperature coefficient of capacitance, positive or negative, linear, and reversible. High insulation resistance. No voltage dependence. High long-term stability of electrical values.	High capacitance values with small dimensions. Non-linear dependence of capacitance on temperature.
DC Voltage Capacitance Dependence	None	Increasing with ϵ
Dissipation Factor $\tan \delta$	Maximum 1.5×10^{-3} (typical)	Maximum 35×10^{-3} (typical)
Insulation Resistance	$\geq 10^{10} \Omega$	$\geq 10^9 \Omega$
Capacitance Tolerances	$\pm 5 \%$, $\pm 10 \%$, $\pm 20 \%$	$\pm 10 \%$, $\pm 20 \%$, $+50 \%$ / -20% , $+80 \%$ / -20%
Rated Voltage	Up to 25 kV _{DC}	Up to 15 kV _{DC}

STANDARD SPECIFICATIONS	
GENERAL STANDARDS	
IEC 60062	Marking codes for resistors and capacitors
IEC 60068	Basic environmental testing procedures
SPECIAL STANDARDS FOR CERAMIC CAPACITORS	
EN 130600 and IEC 60384-8	Fixed capacitors of ceramic dielectric, class 1
EN 130700 and IEC 60384-9	Fixed capacitors of ceramic dielectric, class 2
STANDARDS FOR SPECIAL APPLICATION PURPOSES	
IEC 60384-14	RFI and safety capacitors
DIN EN 60384-14	
UL 60384-14	
CSA E60384-14	

MEASURING AND TESTING CONDITIONS		
	CLASS 1	CLASS 2
Capacitance and Dissipation Factor	$C \geq 1000 \text{ pF}$ 1 kHz, $1.0 V_{\text{RMS}}$ to $5 V_{\text{RMS}}$ $C < 1000 \text{ pF}$ 1 MHz, $1.0 V_{\text{RMS}}$ to $5 V_{\text{RMS}}$	$C \geq 100 \text{ pF}$ 1 kHz, $1.0 V_{\text{RMS}} \pm 0.2 V_{\text{RMS}}$ $C < 100 \text{ pF}$ 1 MHz, $1.0 V_{\text{RMS}} \pm 0.2 V_{\text{RMS}}$
Insulation Resistance	Rated voltage < 100 V: $\geq 100 \text{ V}$ to < 500 V: $\geq 500 \text{ V}$: Measuring time:	measuring voltage = $10 \text{ V} \pm 1 \text{ V}$ measuring voltage = $100 \text{ V} \pm 15 \text{ V}$ measuring voltage = $500 \text{ V} \pm 50 \text{ V}$ 60 s \pm 5 s
Dielectric Strength	Rated voltage: $\leq 500 \text{ V}$: > 500 V: Testing time:	test voltage = $2.5 \times U_{\text{R}}$ test voltage = $1.5 \times U_{\text{R}}$ 2 s

Note

- Climatic test conditions: Temperature 20 °C to 25 °C
Relative humidity 50 % to 70 %



MARKING

See individual datasheet.

CAPACITANCE CODING SYSTEM			
CAPACITANCE VALUE	CODE	CAPACITANCE VALUE	
	p33	0.33 pF	
	3p3	3.3 pF	
	33p	33 pF	
	330p	330 pF	
	n33	330 pF (0.33 nF)	
	3n3	3300 pF (3.3 nF)	
	33n	33 000 pF (33 nF)	
	330n	330 000 pF (330 nF)	
	μ33	0.33 μF	
	3μ3	3.3 μF	
CAPACITANCE TOLERANCE	CODE LETTER	C-TOLERANCE < 10 pF (pF)	C-TOLERANCE ≥ 10 pF (%)
	B	± 0.1	-
	C	± 0.25	-
	D	± 0.5	± 0.5
	F	± 1	± 1
	G	± 2	± 2
	H	-	± 2.5
	J	-	± 5
	K	-	± 10
	L	-	± 15
	M	-	± 20
	R	-	(+ 30 / - 20)
	S	-	(+ 50 / - 20)
	Z	-	(+ 80 / - 20)
RATED VOLTAGE	Clear text		

PRODUCTION CODE ACCORDING TO IEC 60062

The production code is indicated either with a 2 FIGURE CODE or with a 4 FIGURE CODE.

2 FIGURE CODE (YEAR / MONTH)

The 1st figure indicates the year and the 2nd figure indicates the month.

YEAR	2010	2011	2012	2013	2014	2015	2016	2017	2018	2019	2020	2021	2022	2023	2024	2025	2026	2027	2028	2029	2030
LETTER CODE	A	B	C	D	E	F	H	J	K	L	M	N	P	R	S	T	U	V	W	X	A

MONTH	January	February	March	April	May	June	July	August	September	October	November	December
LETTER / NUMBER CODE	1	2	3	4	5	6	7	8	9	O	N	D

4 FIGURE CODE (YEAR / WEEK)

The 1st two figures indicate the year and the second two figures indicate the week.

EXAMPLES

2014 March = E3
2017 December = JD
2019 May = L5

EXAMPLES

19th week 2014 = 1419
12th week 2016 = 1612
35th week 2020 = 2035

CLASS 1 CERAMIC TYPE TEMPERATURE COEFFICIENT OF THE CAPACITANCE FOR CLASS 1 CERAMIC CAPACITORS

$$\frac{\Delta C}{C} [\%] = 100 \times \alpha \times \Delta \vartheta$$

ΔC = capacitance change
 α = temperature coefficient in 10⁻⁶/°C
 $\Delta \vartheta$ = temperature change in °C

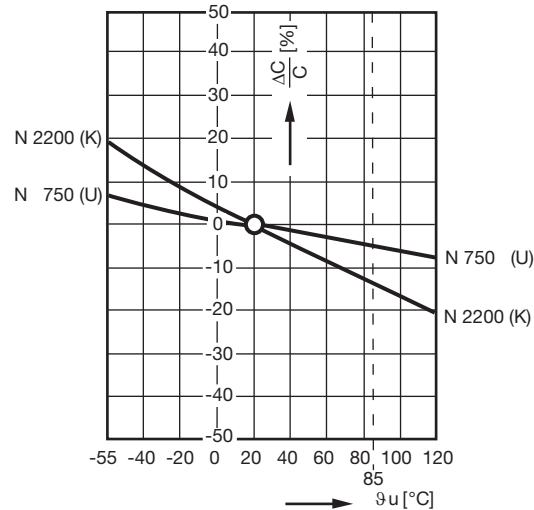

VOLTAGE DEPENDENCE OF CAPACITANCE

None

FREQUENCY DEPENDENCE OF CAPACITANCE

Maximum -2 at 1 MHz

DISSIPATION FACTOR

- For values greater than 50 pF: see datasheet
- For lower values the dissipation factor is calculated according to the type of ceramic (rated temperature coefficient) under consideration of the capacitance according to EN 130600

$$+100 \leq \alpha < -750: \quad 1.5 \times \left(\frac{150}{C} + 7 \right) \times 10^{-4}$$

$$+750 \leq \alpha < -1500: \quad 2 \times \left(\frac{150}{C} + 7 \right) \times 10^{-4}$$

$$+1500 \leq \alpha < -3300: \quad 3 \times \left(\frac{150}{C} + 7 \right) \times 10^{-4}$$

$$+3300 \leq \alpha < -5600: \quad 4 \times \left(\frac{150}{C} + 7 \right) \times 10^{-4}$$

$$\alpha \geq -5600: \quad 5 \times \left(\frac{150}{C} + 7 \right) \times 10^{-4}$$

- The dissipation factor as well as the measuring method to be agreed between manufacturer and user for values lower than 5 pF.

CLASS 2 CERAMIC TYPE

CAPACITANCE CHANGE AND DISSIPATION FACTOR VS. TEMPERATURE

CAPACITANCE CHANGE AND DISSIPATION FACTOR VS. FREQUENCY

CAPACITANCE CHANGE VS. DC VOLTAGE

CERAMIC DIELECTRIC: 2D3 / Y5T

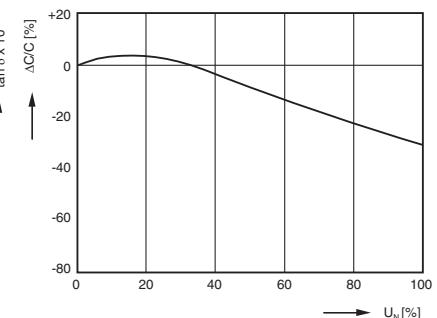
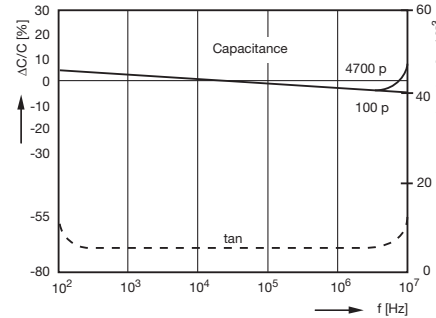
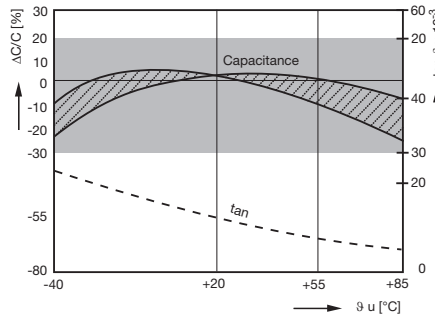

CERAMIC DIELECTRIC: 2E3 / Y5U

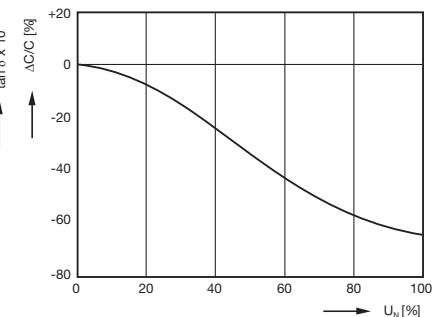
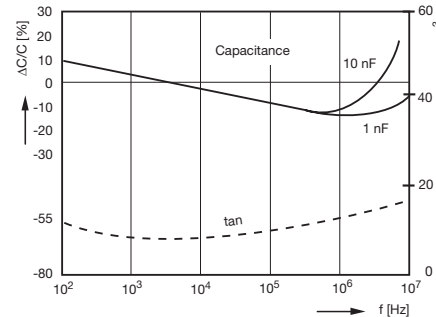
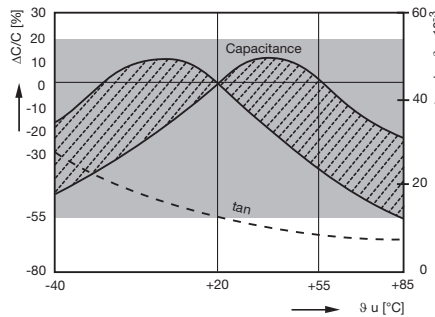

CERAMIC DIELECTRIC: 2F3 / Y5V

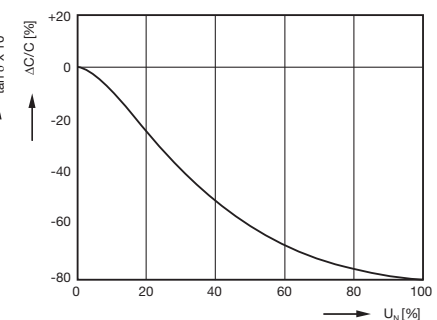
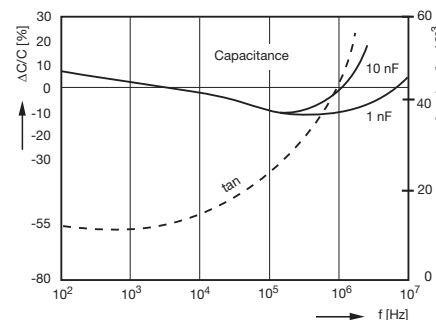
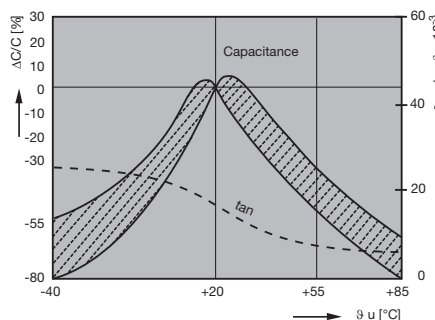



CAPACITANCE “AGING” OF CERAMIC CAPACITORS

Following the final heat treatment all class 2 ceramic capacitors reduce their capacitance value approximately according to logarithmic law due to their special crystalline construction. This change is called “aging”. If the capacitors are heat treated, for example when soldering, the capacitance increases again to a higher value and the aging process begins again.

Note

- The level of this de-aging is dependent on the temperature and the duration of the heat; an almost complete de-aging is achieved at 150 °C in one hour; these conditions also form the basis for reference measurements when testing. The capacitance change per time decade (aging constant) differs for the various types of ceramic but typical values can be taken from the table below.

CERAMIC MATERIAL	Y5T	Y5U	Y5V
AGING CONSTANT k	-4 %	-4 %	-5 %

$$k = \frac{100 \times (C_{t1} - C_{t2})}{C_{t1} \times \log_{10}(t1/t2)}$$

t1, t2 = measuring time point (h)
 C_{t1}, C_{t2} = capacitance values for the times t1, t2
 k = aging constant (%)

$$C_{t2} = C_{t1} \times (1 - k/100 \times \log_{10} [t1/t2])$$

REFERENCE MEASUREMENT

Due to aging it is necessary to specify an age for reference measurements which can be related to the capacitance with fixed tolerance. According to EN 130700 this time period is 1000 h.

If the shelf-life of the capacitor is known, the capacitance for t = 1000 h can be calculated with the aging constant.

In order to avoid the influence of the aging, it is important to de-age the capacitors before stress-testing. The following procedure is adopted (see also EN 130700):

- De-aging at 150 °C, 1 h
- Storage for 24 h at standard climatic conditions
- Initial measurement
- Stress
- De-aging at 150 °C, 1 h
- Storage for 24 h at standard climatic conditions
- Final measurement



COMPONENT CLIMATIC CATEGORY

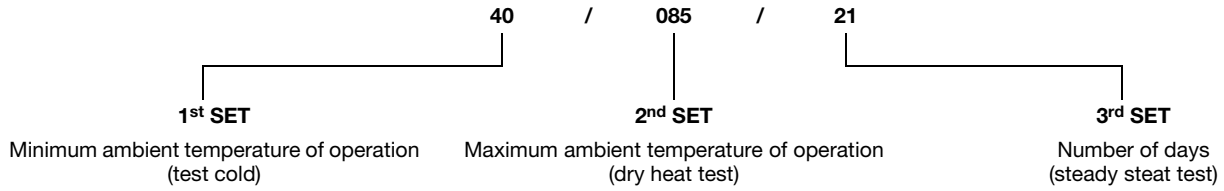

First set: two digits denoting the minimum ambient temperature of operation (cold test).

65	-65 °C
55	-55 °C
40	-40 °C
25	-25 °C
10	-10 °C
00	0 °C
05	+5 °C

Second set: three digits denoting the maximum ambient temperature (dry heat test).

155	+155 °C
125	+125 °C
110	+110 °C
090	+90 °C
085	+85 °C
080	+80 °C
075	+75 °C
070	+70 °C
065	+65 °C
060	+60 °C
055	+55 °C

Third set: two digits denoting the number of days of the damp heat steady state test (Ca).

56	56 days
21	21 days
10	10 days
04	4 days
00	The component is not required to be exposed to damp heat

Standard coding according to IEC 60068-1.

CATEGORY EXAMPLES
25/085/04
25/085/21
40/085/21
55/125/21
55/125/56



STORAGE

The capacitors must not be stored in a corrosive atmosphere, where sulphide or chloride gas, acid, alkali or salt are present. Exposure of the components to moisture, should be avoided. The solderability of the leads is not affected by storage of up to 24 months (temperature +10 °C to +35 °C, relative humidity up to 60 %). Class 2 ceramic dielectric capacitors are also subject to aging, see previous page.

SOLDERING

SOLDERING SPECIFICATIONS		
Soldering test for capacitors with wire leads: (according to IEC 60068-2-20, solder bath method)		
	SOLDERABILITY	RESISTANCE TO SOLDERING HEAT
Soldering temperature	235 °C ± 5 °C	260 °C ± 5 °C
Soldering duration	2 s ± 0.5 s	10 s ± 1 s
Distance from component body	≥ 2 mm	≥ 5 mm

SOLDERING RECOMMENDATIONS

Soldering of the component should be achieved using a Sn60/40 type or a silver-bearing Sn62/36/2Ag type solder. Ceramic capacitors are very sensitive to rapid changes in temperature (thermal shock) therefore the solder heat resistance specification (see Soldering Specifications table) should not be exceeded. Subjecting the capacitor to excessive heating may result in thermal shocks that can crack the ceramic body. Similarly, excessive heating can cause the internal solder junction to melt.

CLEANING

The components should be cleaned immediately following the soldering operation with vapor degreasers.

SOLVENT RESISTANCE

The coating and marking of the capacitors are resistant to the following test method: IEC 60068-2-45 (method XA).

MOUNTING

If a defined product stop is required for mounting on a PCB, a mechanically formed product stop (kinked or inline wire) or a mounting tool should be used.

We do not recommend modifying the lead terminals, e.g. bending or cropping. This action could break the coating or crack the ceramic insert. If however, the lead must be modified in any way, we recommend support of the lead with a clamping fixture next to the coating.



AQL / FIT VALUES / SUPPLIED QUALITY
AQL 0.1 FOR THE SUM OF THE ELECTRIC MAIN FAULTS

- C-tolerance > 1.5 x tolerance limit
- DF > 1.5 x catalog value
- R_{IS} < catalog value
- Inadequate dielectric breakdown
- Interruption

AQL 0.25 FOR THE SUM OF THE MECHANICAL MAIN FAULTS

- Marking wrong or missing
- Dimensions out of tolerance
- Coating failure
- Lead space out of tolerance
- Poor solderability of leads
- Wrong lead length

AQL 0.65 FOR SECONDARY FAULTS

- Coating extension out of tolerance
- Marking incomplete
- Tape dimensions out of tolerance
- Testing in accordance to IEC 60410

Notes

The following agreements are possible on request:

- Lower AQL values
- Confirmed initial random sampling test with appropriate report
- Report on production test findings
- Agreement on ppm concept

RELIABILITY

By careful control of the manufacturing process stages, the quality of the product is maintained at the highest possible level. To obtain data on the reliability of our ceramic capacitors, many long-term tests under increased temperature and voltage conditions have been carried out in our laboratories.

Based on the results of these tests, the following can be stated:

Reference conditions:	Ambient temperature:	40 °C ± 2 °C
	Relative humidity:	60 % ± 2 %
	Electrical stress:	50 % rated voltage (U _R)

Failure criteria: Short circuit (R ≤ 10⁻⁵ Ω) or open circuit

Failure tests:	Class 1 capacitors:	λ = 2 x 10 ⁻⁹ h ⁻¹
	Class 2 capacitors:	λ = 5 x 10 ⁻⁹ h ⁻¹

By derating the voltage load, greatly increased reliability can be predicted. Temperature, up to the maximum category temperature, is not believed to significantly affect the reliability.



PRODUCTION FLOWCHART

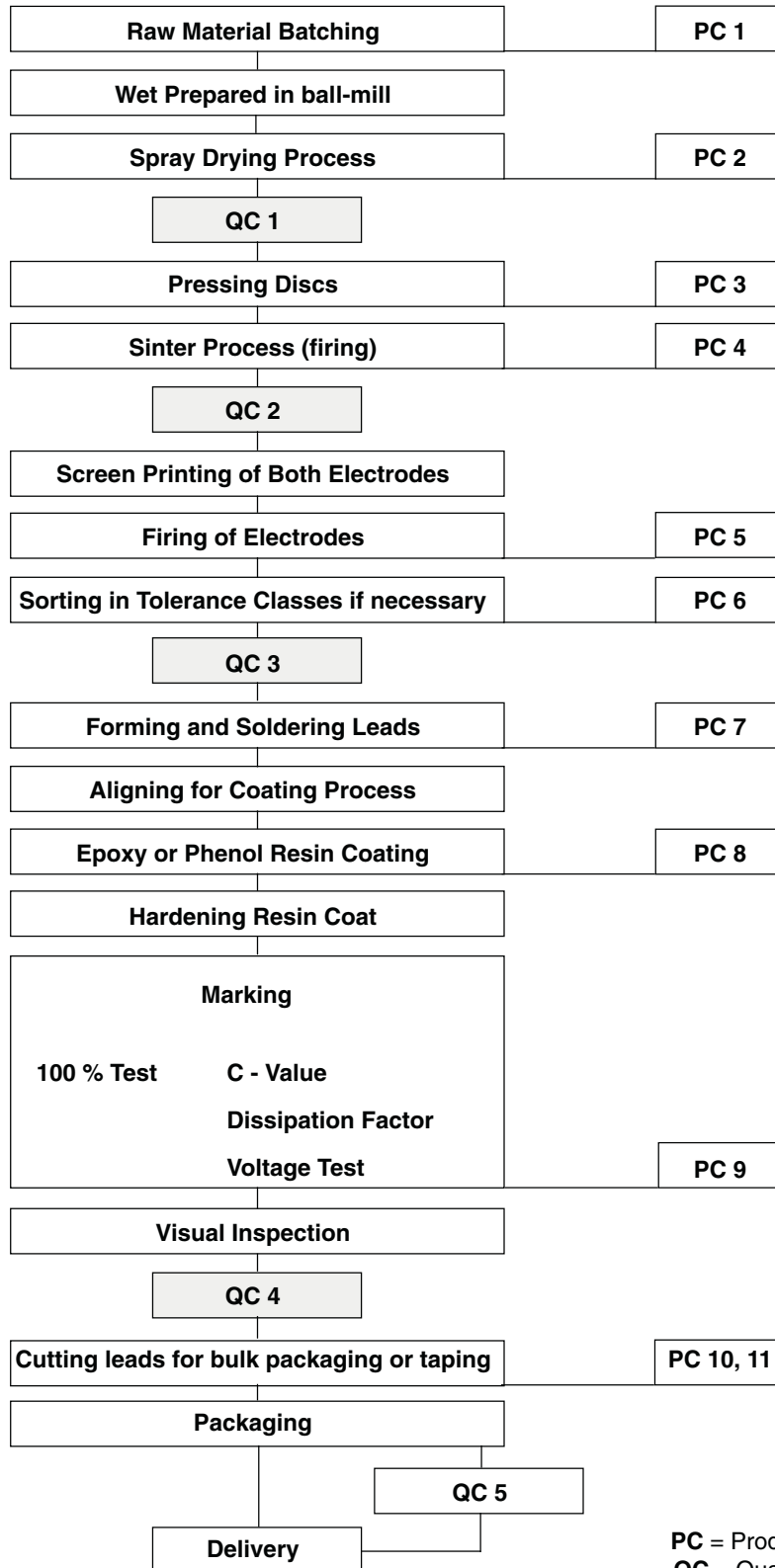

PC = Production Control
QC = Quality Control

AVAILABLE STANDARD LEAD CONFIGURATIONS

FORM 1
STRAIGHT LEAD

e	3.0 MAX.
L	30 - 3 or 10 ± 1

d	0.6 or 0.8
F	5.0* / 7.5 / 10 / 12.5

*) only when d = 0.6

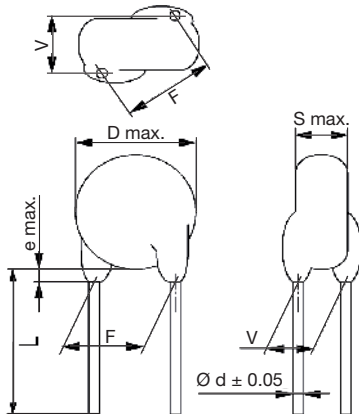

FORM 4
7.5 to 5.0 CRIMP

d	0.6
L	3.0 MIN.

D	B
≤ 9	6.8 ± 0.7
> 9	7.5 ± 0.7

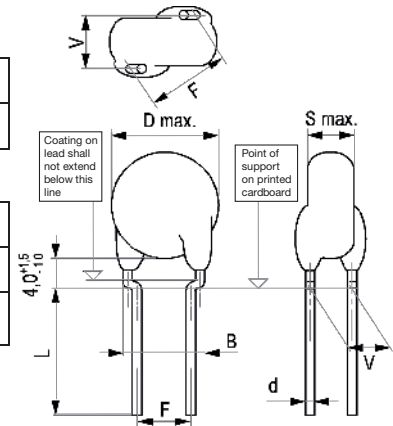

FORM 2
INSIDE CRIMP

d	0.6 or 0.8
L	3.0 MIN.

F	A
5.0*	4.0 - 1 + 0.5
7.5	4.0 ± 1.5
10	5.0 ± 1.5
12.5	6.0 ± 1.5

*) only when d = 0.6

WYO series: Kink = 1.4 + 0.5 - 0.2

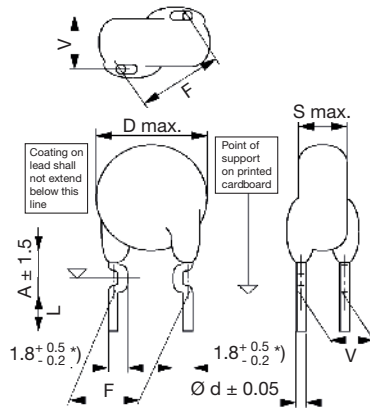

FORM 5
SNAP-IN

d	0.6	0.8
F	5.0* / 7.5 / 10 / 12.5	
L	2.8 MIN.	3.5 MIN.
H	2.6	3.3
P1	1.25	1.65
P2	1.65	1.95

*) only when d = 0.6

D	B
≤ 8	6.0 ± 1.5
> 8	7.0 ± 1.5

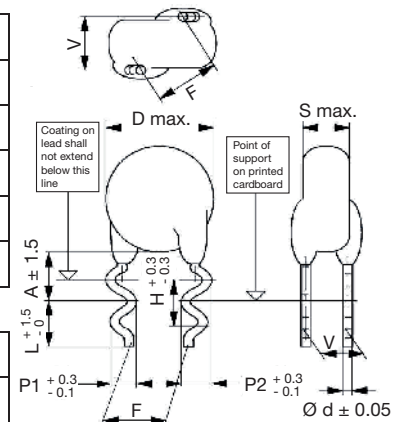

FORM 3
OUTSIDE CRIMP

F	d	A ± 1
5.0*	0.6	5.0
7.5	0.6	5.0
7.5	0.8	6.0
10	0.6	6.0
10	0.8	6.0
12.5	0.6	6.0
12.5	0.8	6.0

*) only when d = 0.6

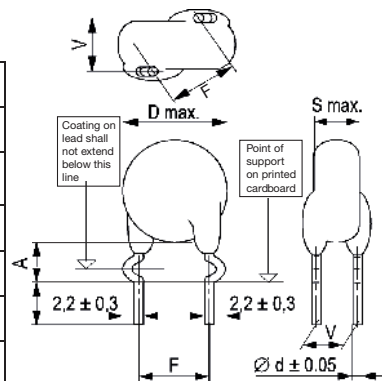

FORM 6
INLINE WIRE

F	d	A
5.0	0.6	4.5 MAX.
7.5	0.6	4.5 MAX.
10	0.8	6.0 MAX.
12.5	0.8	6.0 MAX.

F	L
7.5	2.8 MIN.
10	3.0 MIN.
12.5	3.0 MIN.

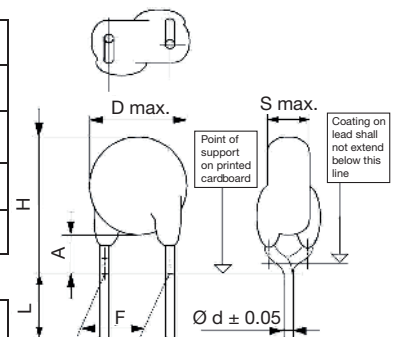

Note

- If a defined product stop is required for mounting on a PCB, a mechanically formed product stop (kinked or inline wire) or a mounting tool should be used

RADIAL TAPING OF CERAMIC DISC CAPACITORS					
DESIGNATION	SYMBOL	TAPING P	TAPING T	TAPING U	TAPING F
Pitch of component	P	12.7 ± 1		25.4 ± 1	
Pitch of sprocket hole	P ₀	12.7 ± 0.3		12.7 ± 0.3	
Distance, hole to lead	P ₁	3.85 ± 0.7		(0.5F) ± 0.7	
Distance, hole to center of component	P ₂	6.35 ± 1.3		12.7 ± 1.3	
Lead spacing	F	5.0 / 7.5 + 0.8 / - 0.2		5 / 7.5 / 10 / 12.5 ± 0.8	
Average deviation across tape	Δh	± 2.0 max.		± 3.0 max.	
Average deviation in direction of reeling	Δp	± 1.3 max.		± 1.3 max.	
Carrier tape width	W	18.0 + 1 / - 0.5		18.0 + 1 / - 0.5	
Hold-down tape width	W ₀	6		6	
Position of sprocket hole	W ₁	9.0 + 0.75 / - 0.5		9.0 + 0.75 / - 0.5	
Distance of hold-down tape	W ₂	3.0 max.		3.0 max.	
Distance between the abscissa and the bottom plane of the component body (straight leads)	H	16.5 ± 0.5	18.0 + 2 / - 0	20 ± 1	16.5 ± 0.5 18.0 + 2 / - 0 20.0 ± 1
Distance between the abscissa and the reference plane of the component with crimped leads (kinked leads)	H ₀	16.0 ± 0.5		16.0 ± 0.5	
Length of cut leads	L	11.0 max.		11.0 max.	
Diameter of sprocket hole	D ₀	4.0 ± 0.2		4.0 ± 0.2	
Total tape thickness	t	0.9 max.		0.9 max.	

PACKAGING VERSIONS

Reel Packaging

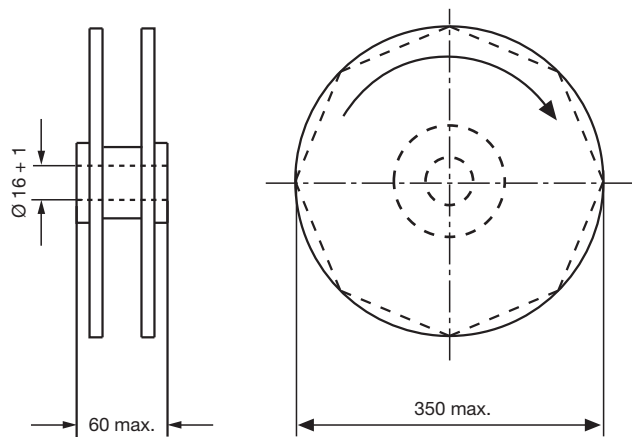

Ammo Packaging

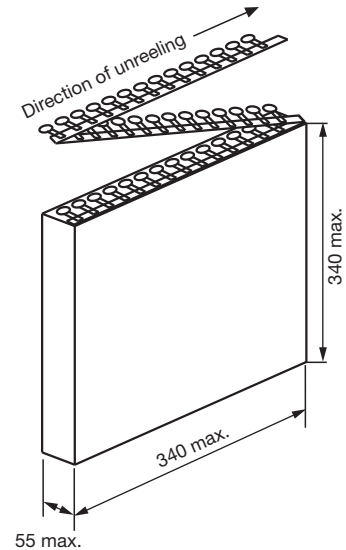



TAPING P / T / U COMPONENT PITCH 0.5" LEAD SPACING 5.0 mm

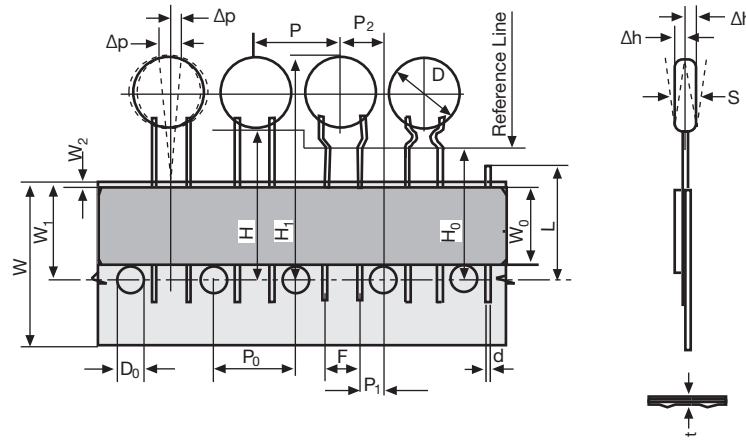

TAPING P / T / U COMPONENT PITCH 0.5" LEAD SPACING 7.5 mm

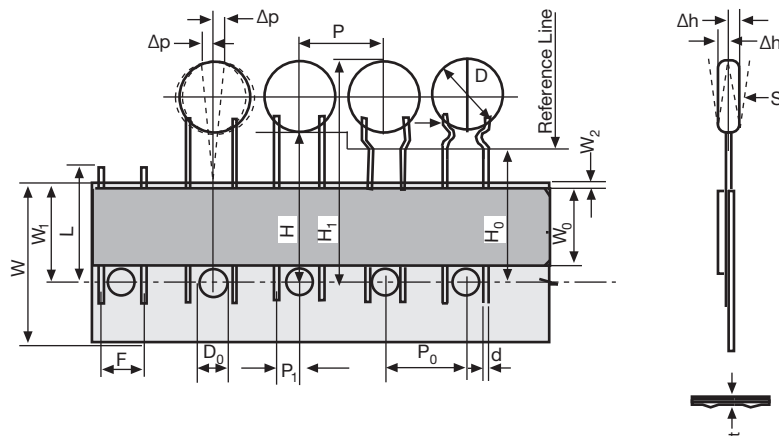

TAPING F COMPONENT PITCH 1.0" LEAD SPACING 5.0 mm, 7.5 mm, 10 mm, 12.5 mm

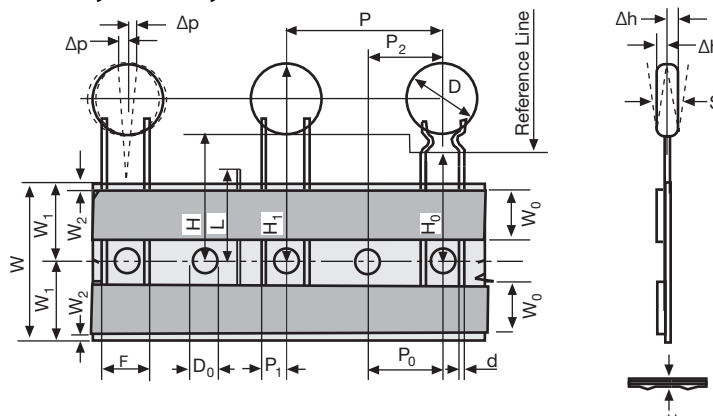

- Pulling force from the tape ≥ 5 N
- Tensile strength of tape ≥ 15 N
- Unreeling force of tape from reel ≥ 2.5 N

Maximum 0.5 % of all components on reel may be missing. A maximum of 3 consecutive components may be missing provided this gap is followed by 6 consecutive components. The splices shall have the same minimum strength as the tape. The splices must be not thicker than 1.5 mm, the sprocket holes may not be effected.



The ordering code is made up of a 14-digit code.

ORDERING INFORMATION						
EXAMPLE H... / I... / V... / W... SERIES						
WYO	472	M	CM	CF0	K	R
1 2 3	4 5 6	7	8 9	10 11 12	13	14
CAPACITOR SERIES	CAPACITANCE VALUE IN pF	TOLERANCE	RATED VOLTAGE	LEAD CONFIGURATION	INTERNAL CODE	RoHS
To be taken from the respective individual datasheet	1 st two digits represent significant figures 3 rd digit is the multiplier (x 10) e.g. 1.6 pF = 916 10 pF = 100 120 pF = 121 4700 pF = 472 22 nF = 223	J = ± 5 % K = ± 10 % M = ± 20 % S = + 50 % / - 20 % Z = + 80 % / - 20 %	AQ = 500 V _{DC} BA = 1 kV _{DC} BB = 2 kV _{DC} BC = 3 kV _{DC} BD = 4 kV _{DC} BE = 5 kV _{DC} BF = 6 kV _{DC} BP = 8 kV _{DC} BH = 10 kV _{DC} BJ = 15 kV _{DC} BQ = 25 kV _{DC} W1X Series: CV = 275 V _{AC} WYO Series: CM = 250 V _{AC} , 440 V _{AC} VKO Series: CQ = 300 V _{AC} , 440 V _{AC} WKO Series: CP = 300 V _{AC} , 440 V _{AC} WKP Series: CQ = 500 V _{AC} , 760 V _{AC} WKP Series: CP = 500 V _{AC} , 760 V _{AC}	<u>STRAIGHT LEADS OR INSIDE CRIMP</u> 10th digit Lead spacing B = 5.0 mm C = 7.5 mm D = 10 mm E = 12.5 mm 11th digit ⁽¹⁾ Lead length / dia. B = 6 + 0 - 1 / 0.6 D = 10 ± 1 / 0.6 H = 10 ± 1 / 0.8 Y = ≥ 20 / 0.6 F = 30 - 3 / 0.6 J = 30 - 3 / 0.8 S = ≥ 30 / 0.6 P = 45 ± 2 / 0.6 R = tape and reel L = tape and ammo 12th digit ⁽¹⁾ 0 = bulk Other = special type <u>OTHER LEAD CONFIGURATION</u> 10th digit Q = snap-in T = outside crimp U = 7.5 mm to 5 mm Y = inline wire <u>SPECIALTY</u> 10th digit R or S		 RoHS COMPLIANT RoHS compliant indicator

Note

⁽¹⁾ The schematic of the 11th and 12th digit is only applicable if the 10th digit is B, C, D, or E.



ORDER CODE, 10th, 11th AND 12th DIGIT - POSSIBLE LEAD AND PACKAGING COMBINATIONS

BULK PACKAGING						
	LEAD LENGTH L	LEAD DIA. d	LEAD SPACING F			
			5 mm	7.5 mm	10 mm	12.5 mm
Straight leads	30 mm - 3 mm	0.6 mm	BF0	CF0	DF0	EF0
		0.8 mm	-	CJ0	DJ0	EJ0
	10 mm ± 1 mm	0.6 mm	BD0	CD0	DD0	ED0
		0.8 mm	-	CH0	DH0	EH0
	6 mm - 1 mm	0.6 mm / 0.8 mm	BB0	CB0	DB0	EB0
	Preformed leads inside crimp	30 mm - 3 mm	0.6 mm	BFG	CFG	DFG
0.8 mm			-	CJG	DJG	EJG
Preformed leads outside crimp	5 mm ± 1 mm	0.6 mm	TA0	TC0	TE0	TG0
		0.8 mm	-	TD0	TF0	TH0
Preformed leads snap-in	Min. 2.8 mm	0.6 mm	QA0	QC0	QE0	QG0
	Min. 3.5 mm	0.8 mm	-	QD0	QF0	QH0
Inline wire	Min. 2.8 mm + 1.5 mm	0.6 mm	YA0	YC0	YE0	YG0
	Min. 3.0 mm + 2.0 mm	0.8 mm	YB0	YD0	YF0	YH0

REEL PACKAGING COMPONENT PITCH 12.7 mm						
	TAPING P		TAPING T		TAPING U	
Lead diameter 0.6 mm	H = 16.5 mm		H = 18.0 mm straight leads only H ₀ = 16.0 mm preformed leads only		H = 20.0 mm	
Lead spacing F	5 mm	7.5 mm	5 mm	7.5 mm	5 mm	7.5 mm
Body diameter D	Valid for ≤ 12 mm standard (> 12 mm to ≤ 13 mm on request)					
Straight leads	BRE	CRE	BRA	CRA	BRC	CRC
Preformed leads inside crimp	-	-	BRB	CRB	-	-
Preformed leads outside crimp	-	-	TAR	TCR	-	-
Preformed leads 7.5 mm to 5 mm	-	-	UAR	-	-	-
Preformed leads snap-in	-	-	QAR	QCR	-	-
Inline wire	-	-	YBR	YCR	-	-

REEL PACKAGING COMPONENT PITCH 25.4 mm						
	TAPING F					
Lead spacing F			5 mm	7.5 mm	10 mm	12.5 mm
Body diameter D			> 12 mm		All diameters	
Straight leads	H = 16.5 mm		BRT	CRT	DRT	ERT
	H = 18.0 mm		BRU	CRU	DRU	ERU
	H = 20.0 mm		BRY	CRY	DRY	ERY
Preformed leads inside crimp	H ₀ = 16.0 mm		BRZ	CRZ	DRZ	ERZ
Preformed leads outside crimp	H ₀ = 16.0 mm		-	-	TDR	TER
Inline wire	H ₀ = 16.0 mm		YRB	YRC	YRD	YRE

Note

- The lead diameter of the taped components is depending on the capacitance value and corresponds with the data given in the individual datasheets

AMMO PACKAGING COMPONENT PITCH 12.7 mm						
	TAPING P		TAPING T		TAPING U	
Lead diameter 0.6 mm	H = 16.5 mm		H = 18.0 mm straight leads only H ₀ = 16.0 mm preformed leads only		H = 20.0 mm	
Lead spacing F	5 mm	7.5 mm	5 mm	7.5 mm	5 mm	7.5 mm
Disc diameter D	Valid for ≤ 12 mm standard (> 12 mm to ≤ 13 mm on request)					
Straight leads	BLE	-	BLA	CLA	BLC	-
Preformed leads inside crimp	-	-	BLB	CLB	-	-
Preformed leads 7.5 mm to 5 mm	-	-	UAL	-	-	-
Inline wire	-	-	YAL	YLC	-	-

Note

- If a defined product stop is required for mounting on a PCB, a mechanically formed product stop (kinked or inline wire) or a mounting tool should be used