

Aluminum Capacitors Power Printed Wiring Style

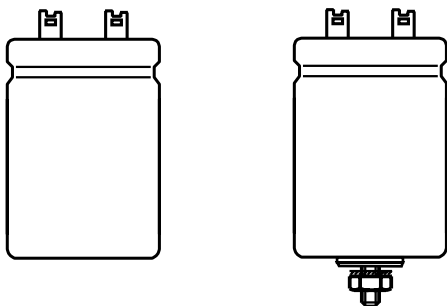

Component outlines

RoHS
COMPLIANT

FEATURES

- Polarized aluminum electrolytic capacitors, non-solid electrolyte
- Large types, cylindrical aluminum case, insulated
- Provided with keyed polarity
- Very long useful life: 15 000 h at 85 °C
- Low ESR, high ripple current capability
- High resistance to shock and vibration

APPLICATIONS

- Computer, telecommunication and industrial systems
- Smoothing and filtering
- Standard and switched mode power supplies
- Energy storage in pulse systems

MARKING

The capacitors are marked (where possible) with the following information:

- Rated capacitance (in μF)
- Tolerance on rated capacitance, code letter in accordance with IEC 60062 (Q for - 10/+ 30 %)
- Rated voltage (in V)
- Date code (YYMM)
- Name of manufacturer
- Code for factory of origin
- Polarity of the terminals and '-' sign to indicate the negative terminal, visible from the top and/or side of the capacitor
- Code number
- Climatic category in accordance with IEC 60068

QUICK REFERENCE DATA

DESCRIPTION	VALUE
	$\leq 100 \text{ V}$
Nominal case size ($\varnothing D \times L$ in mm)	25 x 30 to 40 x 100
Rated capacitance range (E6 series), C_R	470 μF to 68 000 μF
Tolerance on C_R	- 10 % to + 30 %
Rated voltage range, U_R	10 V to 100 V
Category temperature range	- 40 °C to + 85 °C
Endurance test at 85 °C	5000 h
Useful life at 85 °C	15 000 h
Useful life at 40 °C, 1.4 x I_R applied	200 000 h
Shelf life at 0 V, 85 °C	500 h
Based on sectional specification	IEC 60384-4/EN130300
Climatic category IEC 60068	40/085/56

SELECTION CHART FOR C_R , U_R AND RELEVANT NOMINAL CASE SIZES ($\varnothing D \times L$ in mm)

C_R (μF)	U_R (V)					
	10	16	25	40	63	100
470	-	-	-	-	-	25 x 30
680	-	-	-	-	-	25 x 40
1000	-	-	-	-	25 x 30	30 x 40
1500	-	-	-	25 x 30	25 x 40	35 x 40
2200	-	-	25 x 30	25 x 40	30 x 40	35 x 50
3300	-	25 x 30	25 x 40	30 x 40	35 x 40	40 x 50
4700	25 x 30	25 x 40	30 x 40	35 x 40	35 x 50	40 x 70
6800	25 x 40	30 x 40	35 x 40	35 x 50	40 x 50	40 x 100
10 000	30 x 40	35 x 40	35 x 50	40 x 50	40 x 70	-
15 000	35 x 40	35 x 50	40 x 50	40 x 70	40 x 100	-
22 000	35 x 50	40 x 50	40 x 70	40 x 100	-	-
33 000	40 x 50	40 x 70	40 x 100	-	-	-
47 000	40 x 70	40 x 100	-	-	-	-
68 000	40 x 100	-	-	-	-	-

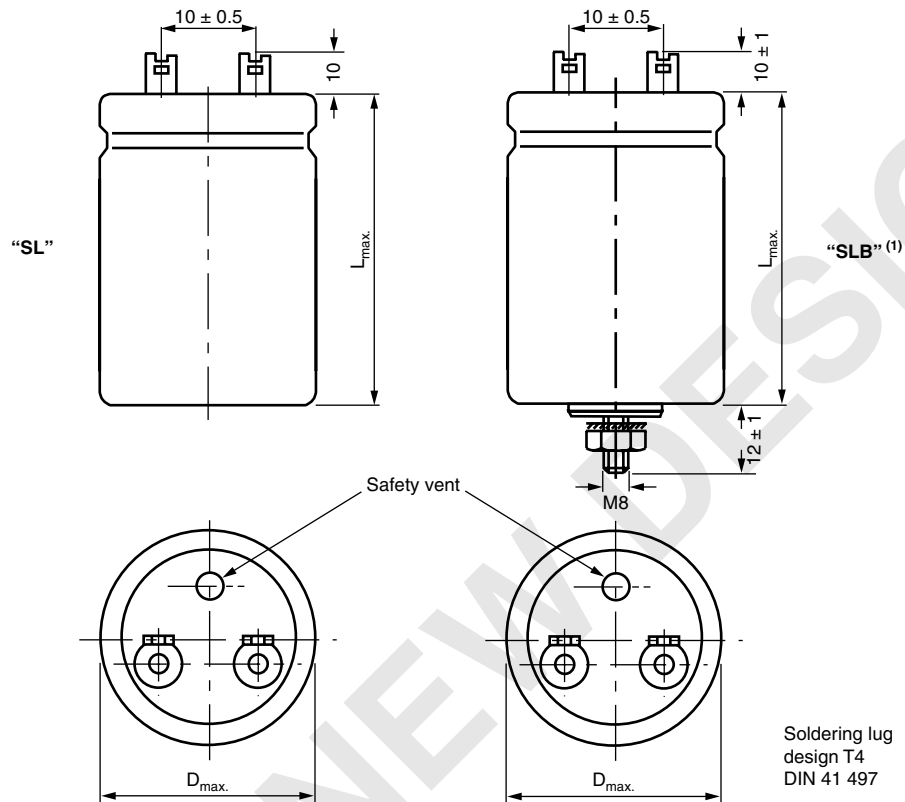
DIMENSIONS in millimeters **AND AVAILABLE FORMS**

Note

(1) The MOQ for SLB-version is 5000 pieces

DIMENSIONS in millimeters, MASS AND PACKAGING QUANTITIES					
NOMINAL CASE SIZE Ø D x L	Ø D _{max.}	L _{max.}	MASS (g)	PACKAGING QUANTITIES (units per box)	CARDBOARD BOX DIMENSIONS L x W x H
25 x 30	26	32	≈ 24	100	290 x 280 x 50
25 x 40	26	42	≈ 28	100	290 x 280 x 60
30 x 40	31	42	≈ 38	100	340 x 330 x 60
35 x 40	36	42	≈ 51	50	390 x 198 x 60
35 x 50	36	52	≈ 66	50	390 x 198 x 70
40 x 50	41	52	≈ 82	50	440 x 223 x 70
40 x 70	41	72	≈ 110	25	230 x 230 x 90
40 x 100	41	102	≈ 176	25	230 x 230 x 120

MOUNTING

When a number of capacitors are connected in a bank, they must not be closer together than 15 mm, when no derating of ripple current and/or temperature is applied.

ELECTRICAL DATA	
SYMBOL	DESCRIPTION
C_R	rated capacitance at 100 Hz
I_R	rated RMS ripple current at 100 Hz, 85 °C or at 20 kHz, 70 °C
I_{L1}	max. leakage current after 1 minute at U_R
I_{L5}	max. leakage current after 5 minutes at U_R
ESR	max. equivalent series resistance at 100 Hz
Z	max. impedance at 10 kHz

Note

(1) Unless otherwise specified, all electrical values apply at $T_a = 20\text{ °C}$, $P = 80\text{ kPa}$ to 120 kPa , $RH = 45\%$ to 75%

ORDERING EXAMPLE

EY01: 10 000 $\mu\text{F}/25\text{ V}$
Version 01: (no stud mounting)
Size: 35 mm x 50 mm
Ordering code: MALLEY01CD510E02W

EY02: 10 000 $\mu\text{F}/25\text{ V}$
Version 02: (stud mounting) ⁽²⁾
Size: 35 mm x 50 mm
Ordering code: MALLEY02CD510E01W

Note

(2) MOQ for Version 02: 5000 pieces

ELECTRICAL DATA AND ORDERING INFORMATION									
U_R (V)	C_R 100 Hz (μF)	NOMINAL CASE SIZE $\varnothing D \times L$ (mm)	I_R 100 Hz 85 °C (A)	I_R 20 kHz 70 °C (A)	I_{L1} 1 min (mA)	I_{L5} 5 min (mA)	ESR 100 Hz ($\text{m}\Omega$)	Z 10 kHz ($\text{m}\Omega$)	ORDERING CODE
10	4700	25 x 30	2.4	4.6	0.28	0.10	74	50	MALLEY01AV447C02W
	6800	25 x 40	3.2	6.1	0.41	0.14	51	37	MALLEY01AB468C02W
	10 000	30 x 40	3.8	7.2	0.60	0.20	39	29	MALLEY01BB510C02W
	15 000	35 x 40	4.1	7.8	0.90	0.30	35	26	MALLEY01CB515C02W
	22 000	35 x 50	5.0	9.5	1.32	0.44	27	21	MALLEY01CD522C02W
	22 000	40 x 40	4.2	8.0	1.32	0.44	36	27	MALLEY01DB522C02W
	33 000	40 x 50	5.0	9.5	1.98	0.66	29	22	MALLEY01DD533C02W
	47 000	40 x 70	6.8	12.9	2.82	0.94	20	17	MALLEY01DG547C02W
68 000	40 x 100	9.2	17.5	4.08	1.36	15	14	MALLEY01DM568C02W	
16	3300	25 x 30	2.4	4.6	0.32	0.11	75	50	MALLEY01AV433D02W
	4700	25 x 40	3.1	5.9	0.45	0.15	52	37	MALLEY01AB447D02W
	6800	30 x 40	3.7	7.0	0.65	0.22	40	30	MALLEY01BB468D02W
	10 000	35 x 40	4.1	7.8	0.96	0.32	36	27	MALLEY01CB510D02W
	15 000	35 x 50	5.0	9.5	1.44	0.48	28	21	MALLEY01CD515D02W
	15 000	40 x 40	4.2	8.0	1.44	0.48	36	27	MALLEY01DB515D02W
	22 000	40 x 50	5.0	9.5	2.12	0.71	29	22	MALLEY01DD522D02W
	33 000	40 x 70	6.7	12.7	3.17	1.06	20	17	MALLEY01DG533D02W
47 000	40 x 100	9.1	17.3	4.51	1.51	15	14	MALLEY01DM547D02W	
25	2200	25 x 30	2.3	4.4	0.33	0.11	78	52	MALLEY01AV422E02W
	3300	25 x 40	3.1	5.9	0.49	0.17	53	38	MALLEY01AB433E02W
	4700	30 x 40	3.7	7.0	0.70	0.24	42	31	MALLEY01BB447E02W
	6800	35 x 40	4.1	7.8	1.02	0.34	37	28	MALLEY01CB468E02W
	10 000	35 x 50	5.0	9.5	1.50	0.50	28	21	MALLEY01CD510E02W
	10 000	40 x 40	4.2	8.0	1.50	0.50	36	27	MALLEY01DB510E02W
	15 000	40 x 50	5.0	9.5	2.25	0.75	29	22	MALLEY01DD515E02W
	22 000	40 x 70	6.8	12.9	3.30	1.10	20	17	MALLEY01DG522E02W
33 000	40 x 100	9.2	17.5	4.95	1.65	15	14	MALLEY01DM533E02W	
40	1500	25 x 30	2.0	3.8	0.36	0.12	112	68	MALLEY01AV415G02W
	2200	25 x 40	2.7	5.1	0.53	0.18	76	51	MALLEY01AB422G02W
	3300	30 x 40	3.3	6.3	0.79	0.27	57	41	MALLEY01BB433G02W
	4700	35 x 40	3.8	7.2	1.13	0.38	48	35	MALLEY01CB447G02W
	6800	35 x 50	4.7	8.9	1.64	0.55	36	27	MALLEY01CD468G02W
	6800	40 x 40	4.1	7.8	1.64	0.55	45	33	MALLEY01DB468G02W
	10 000	40 x 50	4.9	9.3	2.40	0.80	35	27	MALLEY01DD510G02W
	15 000	40 x 70	6.6	12.5	3.60	1.20	25	20	MALLEY01DG515G02W
22 000	40 x 100	9.0	17.1	5.28	1.76	18	16	MALLEY01DM522G02W	
63	1000	25 x 30	1.8	3.4	0.38	0.13	122	74	MALLEY01AV410J02W
	1500	25 x 40	2.5	4.7	0.57	0.19	83	54	MALLEY01AB415J02W
	2200	30 x 40	3.1	5.9	0.83	0.28	57	41	MALLEY01BB422J02W
	3300	35 x 40	3.6	6.8	1.25	0.42	48	35	MALLEY01CB433J02W
	4700	35 x 50	4.4	8.3	1.78	0.60	36	27	MALLEY01CD447J02W
	4700	40 x 40	3.8	7.2	1.78	0.60	45	33	MALLEY01DB447J02W
	6800	40 x 50	4.7	8.9	2.57	0.86	35	27	MALLEY01DD468J02W
	10 000	40 x 70	6.2	11.8	3.78	1.26	25	20	MALLEY01DG510J02W
15 000	40 x 100	8.5	16.1	5.67	1.89	18	16	MALLEY01DM515J02W	

ELECTRICAL DATA AND ORDERING INFORMATION									
U_R (V)	C_R 100 Hz (μ F)	NOMINAL CASE SIZE \varnothing D x L (mm)	I_R 100 Hz 85 °C (A)	I_R 20 kHz 70 °C (A)	I_{L1} 1 min (mA)	I_{L5} 5 min (mA)	ESR 100 Hz (m Ω)	Z 10 kHz (m Ω)	ORDERING CODE
100	470	25 x 30	1.4	2.7	0.28	0.10	247	172	MALLEY01AV347L02W
	680	25 x 40	1.9	3.6	0.41	0.14	170	116	MALLEY01AB368L02W
	1000	30 x 40	2.5	4.7	0.60	0.20	123	88	MALLEY01BB410L02W
	1500	35 x 40	3.1	5.8	0.90	0.30	94	71	MALLEY01CB415L02W
	2200	35 x 50	3.9	7.4	1.32	0.44	69	55	MALLEY01CD422L02W
	2200	40 x 40	3.6	6.8	1.32	0.44	81	65	MALLEY01DB422L02W
	3300	40 x 50	4.6	8.7	1.98	0.66	59	48	MALLEY01DD433L02W
	4700	40 x 70	6.2	11.7	2.82	0.94	42	36	MALLEY01DG447L02W
	6800	40 x 100	8.2	15.5	4.08	1.36	32	28	MALLEY01DM468L02W

ADDITIONAL ELECTRICAL DATA		
PARAMETER	CONDITIONS	VALUE
Voltage		
Surge voltage	≤ 250 V versions	$U_s = 1.15 \times U_R$
Reverse voltage		$U_{rev} \leq 1$ V
Current		
Leakage current	After 1 minute at U_R	$I_{L1} \leq 0.006 C_R \times U_R + 4 \mu$ A
	After 5 minutes at U_R	$I_{L5} \leq 0.002 C_R \times U_R + 4 \mu$ A
Inductance		
Equivalent series inductance (ESL)	Case \varnothing D = 25 mm	max. 25 nH
	Case \varnothing D = 30 and 35 mm	max. 30 nH
	Case \varnothing D = 40 mm	max. 35 nH

LIFETIME TABLE rated voltage: ≤ 100 V

INTERRELATION BETWEEN ALTERNATING CURRENT, AMBIENT TEMPERATURE AND LIFETIME																
I/I_R (frequency dependent)						SURFACE TEMPERATURE RISE ΔT_0 (°C)	LIFETIME MULTIPLIER (depending on I/I_R and T_a)									
FREQUENCY (Hz)							AMBIENT TEMPERATURE T_a (°C)									
50	100	250	500	1000	> 2500		40	45	50	55	60	65	70	75	80	85
0.19	0.20	0.21	0.22	0.22	0.23	0.2	63	40	26	17	11	7.3	5.0	3.4	2.3	1.63
0.38	0.40	0.42	0.43	0.45	0.47	0.7	55	35	23	15	9.9	6.7	4.5	3.1	2.2	1.51
0.56	0.60	0.63	0.65	0.67	0.70	1.5	45	29	19	13	8.5	5.7	3.9	2.7	1.9	1.33
0.75	0.80	0.84	0.86	0.89	0.94	2.5	35	23	15	10	6.9	4.7	3.3	2.3	1.6	1.13
0.94	1.00	1.05	1.08	1.12	1.17	3.8	26	17	12	7.9	5.4	3.7	2.6	1.8	1.3	1.00
1.13	1.20	1.26	1.29	1.34	1.41	5.4	18	13	8.6	5.9	4.1	2.9	2.0	1.4	1.0	
1.31	1.40	1.47	1.51	1.56	1.64	7.4	13	8.7	6.1	4.2	3.0	2.1	1.5	1.1		
1.50	1.60	1.68	1.72	1.79	1.87	9.6	8.3	5.9	4.2	3.0	2.1	1.5	1.1			
1.69	1.80	1.89	1.94	2.01	2.11	12	5.4	3.9	2.8	2.0	1.4	1.0				
1.88	2.00	2.10	2.15	2.23	2.34	15	3.4	2.5	1.8	1.3						
2.06	2.20	2.30	2.37	2.45	2.58	18	2.1	1.5	1.1							
2.25	2.40	2.51	2.58	2.68	2.81	21	1.2									

Notes
 I_R 100 Hz alternating current (A) at upper category temperature T_{UC} taken from datasheet

 I User current (A)

 T_a Ambient temperature of capacitor (°C)

 ΔT_0 Surface temperature rise of capacitor caused by AC load (°C)

 L Lifetime multiplier



Disclaimer

All product specifications and data are subject to change without notice.

Vishay Intertechnology, Inc., its affiliates, agents, and employees, and all persons acting on its or their behalf (collectively, "Vishay"), disclaim any and all liability for any errors, inaccuracies or incompleteness contained herein or in any other disclosure relating to any product.

Vishay disclaims any and all liability arising out of the use or application of any product described herein or of any information provided herein to the maximum extent permitted by law. The product specifications do not expand or otherwise modify Vishay's terms and conditions of purchase, including but not limited to the warranty expressed therein, which apply to these products.

No license, express or implied, by estoppel or otherwise, to any intellectual property rights is granted by this document or by any conduct of Vishay.

The products shown herein are not designed for use in medical, life-saving, or life-sustaining applications unless otherwise expressly indicated. Customers using or selling Vishay products not expressly indicated for use in such applications do so entirely at their own risk and agree to fully indemnify Vishay for any damages arising or resulting from such use or sale. Please contact authorized Vishay personnel to obtain written terms and conditions regarding products designed for such applications.

Product names and markings noted herein may be trademarks of their respective owners.