

## Surface Mount Multilayer Ceramic Chip Capacitors for Commodity Applications

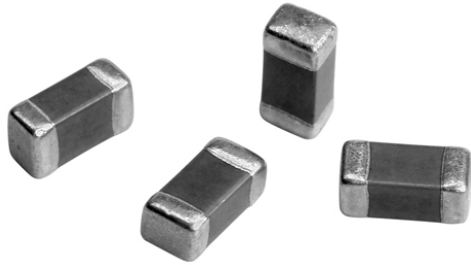

### FEATURES

- Class 3 dielectric
- Four standard sizes
- High capacitance per unit volume
- Supplied in tape on reel
- For high frequency applications
- Ni-barrier with 100 % tin terminations
- Dry sheet technology process
- Base Metal Electrode System (BME)
- Halogen-free according to IEC 61249-2-21



**RoHS**  
COMPLIANT  
HALOGEN  
**FREE**

### APPLICATIONS

- Consumer electronics
- Telecommunications
- Data processing
- Mobile applications

### ELECTRICAL SPECIFICATIONS

**Note:** Electrical characteristics values - temperature at 20 °C, unless otherwise specified

**Operating Temperature:** - 25 °C to + 85 °C

**Capacitance Range:** 100 pF to 22 µF

**Voltage Rating:** 6.3 Vdc to 100 Vdc

**Temperature Coefficient of Capacitance (TCC):**

+ 30 %/- 80 % without voltage applied

**Dissipation Factor (DF):**

**6.3 V:** ≤ 20 %

**10 V:** ≤ 12.5 %

**16 V:** for Cap. < 1 µF ≤ 7.0 %

≤ 9 % for 0402 ≥ 0.068 µF; 0603 ≥ 0.68 µF

**16 V:** for Cap. ≥ 1.0 µF ≤ 9 %

≤ 12.5 % for 0805 ≥ 4.7 µF; 1206 ≥ 10 µF

**25 V:** ≤ 5 %

≤ 7 % for 0402 ≥ 0.047 pF; 0603 ≥ 0.1 µF; 0805 ≥ 0.33 µF; 1206 ≥ 1 µF

≤ 9 % for 0402 ≥ 0.068 µF; 0603 ≥ 0.47 µF; 1206 ≥ 4.7 µF

≥ 50 V: ≤ 5.0 %

≤ 7 % for 0603 ≥ 0.1 µF; 0805 ≥ 0.47 µF

**Aging Rate:**

6.3 V: 12.5 % maximum per decade

10 V/16 V: 9 % maximum per decade

≥ 25 V: 7 % maximum per decade

**Insulation Resistance (IR):**

10 GΩ or 500 ΩF whichever is less

**Dielectric Withstanding Voltage (DWV):**

This is the maximum voltage the capacitors are tested for 1 to 5 s period and the charge/discharge current does not exceed 50 mA

≤ 50 Vdc: DWV at 250 % of rated voltage

100 Vdc: DWV at 300 % of rated voltage

### DIMENSIONS in inches [millimeters]

SIZE CODE	L	W	T MAX.	MB
0402 (1005)	0.040 ± 0.002 [1.0 ± 0.05]	0.020 ± 0.002 [0.5 ± 0.05]	0.022 [0.55]	0.010 + 0.002/- 0.004 [0.25 + 0.05/- 0.10]
0603 (1608)	0.063 + 0.006/- 0.004 [1.6 + 0.15/- 0.10]	0.030 + 0.006/- 0.004 [0.8 + 0.15/- 0.10]	0.038 [0.95]	0.015 ± 0.006 [0.40 ± 0.15]
0805 (2012)	0.080 ± 0.008 [2.0 ± 0.20]	0.050 ± 0.008 [1.25 ± 0.20]	0.058 [1.45]	0.020 ± 0.008 [0.50 ± 0.20]
1206 (3216)	0.125 + 0.012/- 0.004 [3.2 + 0.30/- 0.10]	0.063 + 0.012/- 0.004 [1.6 + 0.30/- 0.10]	0.075 [1.90]	0.025 ± 0.008 [0.60 ± 0.20]

### ORDERING INFORMATION

VJ0402	V	103	M	X	Q	C	W1BC
SIZE CODE	DIELECTRIC	CAPACITANCE	TOLERANCE	TERMINATION	VOLTAGE	PACKAGING	PROCESS CODE FOR BASIC COMMODITY
0402 0603 0805 1206	V = Y5V	two significant digits followed by the number of zeros: 103 = 10 000 pF	M = ± 20 % Z = - 20/+ 80 %	X = Ni-Barrier	Y = 6.3 V Q = 10 V J = 16 V X = 25 V A = 50 V B = 100 V	C = 7" reel/paper P = 13" reel/paper T = 7" reel/blister R = 13" reel/blister	



# VJ...W1BC Y5V Dielectric

Surface Mount Multilayer Ceramic Chip Capacitors  
for Commodity Applications

Vishay

SELECTION CHART																					
DIELECTRIC		Y5V																			
EIA CAP.	EIA SIZE CAP.	0402					0603					0805					1206				
		6.3 V	10 V	16 V	25 V	50 V	100 V	10 V	16 V	25 V	50 V	100 V	10 V	16 V	25 V	50 V	100 V	10 V	16 V	25 V	50 V
102	1000 pF																				
122	1200 pF																				
152	1500 pF																				
182	1800 pF																				
222	2200 pF																				
272	2700 pF																				
332	3300 pF																				
392	3900 pF																				
472	4700 pF																				
562	5600 pF																				
682	6800 pF																				
822	8200 pF																				
103	0.01 µF		N	N	N	N		S	S	S	S		A	A	A	A	B	B	B	B	B
123	0.012 µF		N	N	N	N		S	S	S	S		A	A	A	A		B	B	B	B
153	0.015 µF		N	N	N	N		S	S	S	S		A	A	A	A	B	B	B	B	B
183	0.018 µF		N	N	N	N		S	S	S	S		A	A	A	A		B	B	B	B
223	0.022 µF		N	N	N	N		S	S	S	S		A	A	A	A	B	B	B	B	B
273	0.027 µF		N	N	N	N		S	S	S	S		A	A	A	A		B	B	B	B
333	0.033 µF		N	N	N	N		S	S	S	S		A	A	A	A	B	B	B	B	B
393	0.039 µF		N	N	N			S	S	S	S		A	A	A	A		B	B	B	B
473	0.047 µF		N	N	N			S	S	S	S		A	A	A	A	B	B	B	B	B
563	0.056 µF		N	N	N			S	S	S	S		A	A	A	A		B	B	B	B
683	0.068 µF		N	N	N			S	S	S	S		A	A	A	A	B	B	B	B	B
823	0.082 µF		N	N	N			S	S	S	S		A	A	A	A		B	B	B	B
104	0.1 µF	N	N	N	N			S	S	S	S		A	A	A	A	B	B	B	B	B
154	0.15 µF		N					S	S	S	S		A	A	A	A		B	B	B	C
224	0.22 µF		N					S	S	S			A	A	A	A		B	B	B	C
334	0.33 µF	N	N					S	S	S			B	B	B	B		B	B	B	
474	0.47 µF	N	N					S	S				B	B	B	B		B	B	B	
684	0.68 µF	N						S	X				B	B	D	D		B	B	B	
105	1 µF	N						S	X				B	B	D	D		C	C	C	
155	1.5 µF							S					D	D				C	C	C	
225	2.2 µF							S					D	D				C	C	C	J
335	3.3 µF												D	D				J	J	J	
475	4.7 µF												D	D				J	J	J	
685	6.8 µF												I					J	J		
106	10 µF												I					J	J		
226	22 µF																	P			
336	33 µF																				
476	47 µF																				
686	68 µF																				
107	100 µF																				

**Note:**

Letters indicate product thickness, please see packaging quantities

PACKAGING						
SIZE (inch/mm)	THICKNESS (mm)	THICKNESS SYMBOL	PAPER TAPE		PLASTIC TAPE	
			7" reel (C)	13" reel (P)	7" reel (T)	13" reel (R)
0402 (1002)	0.50 ± 0.05	N	10K	50K		
0603 (1608)	0.80 ± 0.07	S	4K	15K		
	0.80 + 0.15/- 0.10	X	4K	15K		
0805 (2012)	0.60 ± 0.10	A	4K	15K		
	0.80 ± 0.10	B	4K	15K		
	1.25 ± 0.10	D			3K	10K
1206 (3216)	1.25 ± 0.20	I			3K	10K
	0.80 ± 0.10	B	4K	15K		
	0.95 ± 0.10	C			3K	10K
	1.15 ± 0.15	J			3K	10K
	1.25 ± 0.10	D			3K	10K
	1.60 ± 0.20	G			2K	
	1.60 ± 0.30/- 0.10	P			2K	

### COVER TAPE (POLYESTER - ANTISTATIC)

PROPERTIES OF COVER TAPE	
PARAMETER	WIDTH
Breaking force	≥ 10.7 N
Elongation at break	≥ 63 %
Surface resistance	< 10 <sup>10</sup> Ω/sq.
Softening point	71 ± 5 °C
Thickness	62 μm

### CARRIER TAPE (POLYCARBONATE)

PROPERTIES OF CARRIER TAPE	
PARAMETER	WIDTH
Thickness	190 to 280 μm
Tensile strength at break	> 60 N/mm <sup>2</sup>
Elongation at break	100 to 150 %
Surface resistance	> 10 <sup>12</sup> Ω/sq.

### PAPER TAPE SPECIFICATIONS

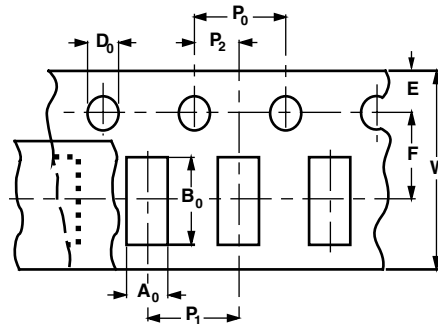

DIMENSIONS OF PAPER TAPE in millimeters								
SYMBOL	PRODUCT SIZE CODE							
	0402		0603		0805		1206	
	SIZE	TOL.	SIZE	TOL.	SIZE	TOL.	SIZE	TOL.
A <sub>0</sub>	0.62	± 0.05	1.02	± 0.05	1.50	± 0.10	2.00	± 0.10
B <sub>0</sub>	1.12	± 0.05	1.82	± 0.05	2.30	± 0.10	3.50	± 0.10
W	8.00	± 0.10	8.00	± 0.10	8.00	± 0.10	8.00	± 0.10
E	1.75	± 0.05	1.75	± 0.05	1.75	± 0.05	1.75	± 0.10
F	3.50	± 0.05	3.50	± 0.05	3.50	± 0.05	3.50	± 0.05
D <sub>0</sub>	1.55	± 0.05	1.55	± 0.05	1.55	± 0.05	1.50	± 0.05
P <sub>0</sub>	4.00	± 0.10	4.00	± 0.10	4.00	± 0.10	4.00	± 0.10
P <sub>1</sub>	2.00	± 0.05	4.00	± 0.10	4.00	± 0.10	4.00	± 0.10
P <sub>2</sub>	2.00	± 0.05	2.00	± 0.05	2.00	± 0.05	2.00	± 0.05



**BLISTER TAPE SPECIFICATIONS**

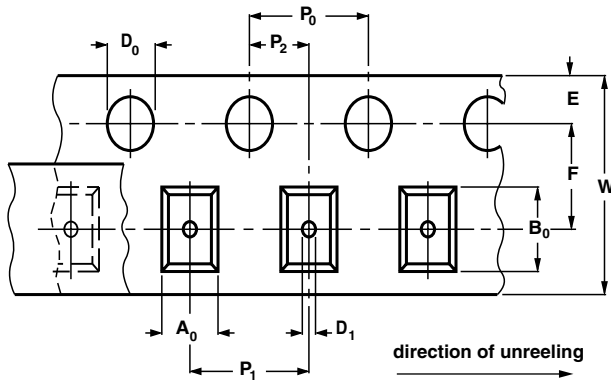

<b>DIMENSIONS OF BLISTER TAPE</b> in millimeters			
DIMENSION	PRODUCT		TOLERANCE
	0805	1206	
A <sub>0</sub>	< 1.57	< 2.00	-
B <sub>0</sub>	< 2.45	< 3.60	-
W	8.00	8.00	± 0.10
E	1.75	1.75	± 0.10
F	3.50	3.50	± 0.05
D <sub>0</sub>	1.50	1.50	± 0.05
D <sub>1</sub>	1.00	1.00	± 0.10
P <sub>0</sub>	4.00	4.00	± 0.10
P <sub>1</sub>	4.00	4.00	± 0.10
P <sub>2</sub>	2.00	2.00	± 0.05

**REEL SPECIFICATIONS**

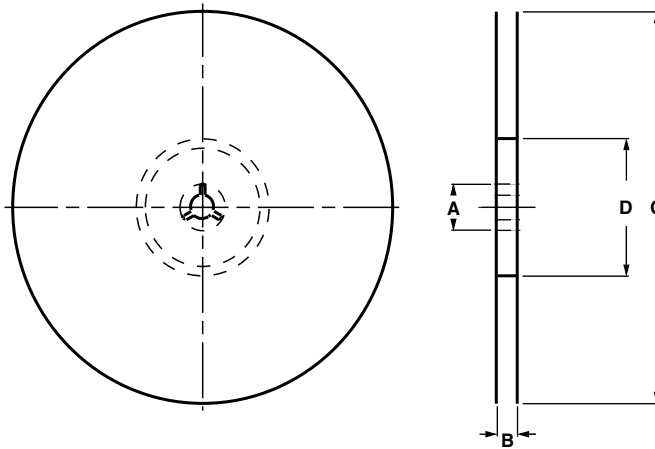

<b>REEL DIMENSIONS AND TAPE WIDTH</b> in millimeters		
	Ø 180 mm; 7"	Ø 330 mm; 13"
A	13.0 ± 1.0	13.0 ± 0.5
B	9.0 ± 1.0	9.0 ± 1.0
C	178.0 ± 1.0	330.0 ± 1.0
D	60.5 ± 1.0	100.0 ± 1.0



## Disclaimer

All product specifications and data are subject to change without notice.

Vishay Intertechnology, Inc., its affiliates, agents, and employees, and all persons acting on its or their behalf (collectively, "Vishay"), disclaim any and all liability for any errors, inaccuracies or incompleteness contained herein or in any other disclosure relating to any product.

Vishay disclaims any and all liability arising out of the use or application of any product described herein or of any information provided herein to the maximum extent permitted by law. The product specifications do not expand or otherwise modify Vishay's terms and conditions of purchase, including but not limited to the warranty expressed therein, which apply to these products.

No license, express or implied, by estoppel or otherwise, to any intellectual property rights is granted by this document or by any conduct of Vishay.

The products shown herein are not designed for use in medical, life-saving, or life-sustaining applications unless otherwise expressly indicated. Customers using or selling Vishay products not expressly indicated for use in such applications do so entirely at their own risk and agree to fully indemnify Vishay for any damages arising or resulting from such use or sale. Please contact authorized Vishay personnel to obtain written terms and conditions regarding products designed for such applications.

Product names and markings noted herein may be trademarks of their respective owners.