

Ø 5 mm Film Dielectric Trimmers

TEST VOLTAGE (DC) FOR 1 MINUTE:

300 V

MAXIMUM CONTACT RESISTANCE:

10 mΩ

MINIMUM INSULATION RESISTANCE:

10 000 MΩ

CATEGORY TEMPERATURE RANGE:**PP**

- 40 to + 70 °C

PC, PTFE

- 40 to + 85 °C

CLIMATIC CATEGORY (IEC 60068):**PP**

40/070/21

PC, PTFE

40/085/21

MINIMUM STORAGE TEMPERATURE:

- 55 °C

RELATED SPECIFICATION:

IEC 60418-1 and 4

EFFECTIVE ANGLE OF ROTATION:

180° (rotation in 180° only, see "Life of Trimmer")

OPERATING TORQUE:**C_{MAX} < 20 pF**

1 to 15 mNm

C_{MAX} ≥ 20 pF

1 to 25 mNm

MAXIMUM AXIAL THRUST:

2 N

FEATURES

- Housing diameter 5 mm
- Top and bottom or top adjustment
- Round head
- Vertical version

APPLICATIONS

- For consumer and industrial equipment

DESCRIPTION:

The vanes of the trimmer are stacked on a sturdy plastic base. The color of the base indicates the maximum capacitance (see Electrical Data Tables). The dielectric is a film of polypropylene (PP) or polytetrafluorethylene (PTFE) for the standard versions and polycarbonate (PC) for the economic and hexagonal head versions. The dielectric supports the vanes in such a way that good stability is ensured and no microphony can occur.

Flux absorption between the vanes is prevented.

Cleaning with solvents is not advised.

QUALITY LEVEL:

Sampling and data evaluation for quality level in accordance with "MIL-STD-105D" and "IEC 60410":

< 0.15 % major defects

< 0.65 % minor defects

Each capacitor is tested for minimum C_{max} and is also subjected to the full test voltage.

C_{min}/C_{max}:

0.35/1.5 to 4/27 pF

RATED VOLTAGE (DC):

150 V

TEST VOLTAGE (DC) FOR 1 MINUTE:

300 V

LIFE OF TRIMMER:

Maximum 10 cycles: Rotation in 180° only (the electrical and mechanical performance is not guaranteed if rotated beyond 10 cycles)

**RoHS**
COMPLIANT

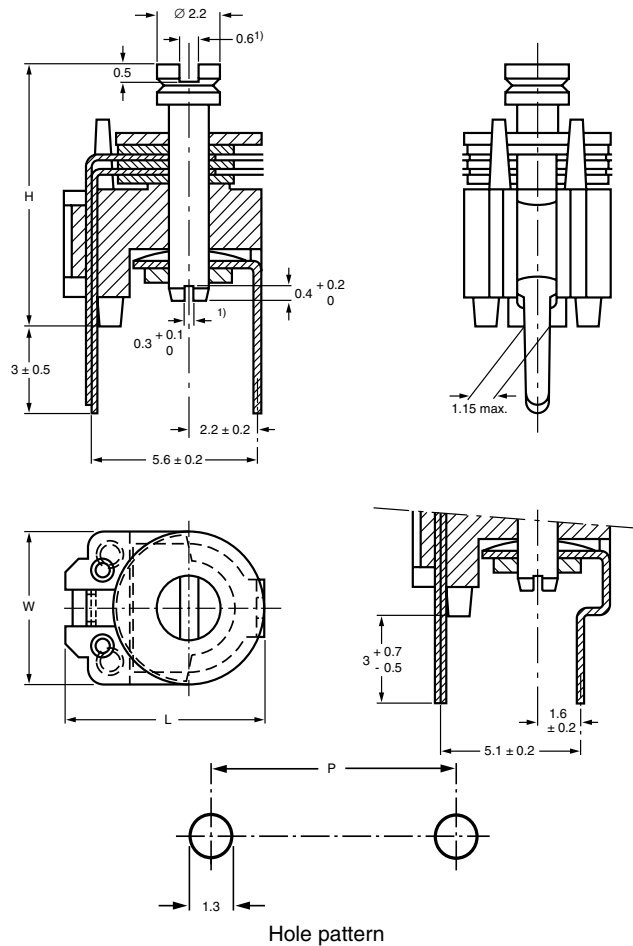

Hole pattern
 Trimmers BFC2 808 series, with round head
 Dimensions in millimeters

STANDARD VERSIONS; CAPACITANCE AND RELEVANT PHYSICAL DIMENSIONS

C_{min}/C_{max} (pF)	H_{max} (mm)	W_{max} (mm)	L_{max} (mm)
0.35/1.5	7.0	5.5	7.3
1.5/5	7.0	5.5	7.3
3/10	7.0	5.5	7.3
3/15	8.8	5.5	7.3
4/20	8.8	5.5	7.3
4/27	9.0	6.2	7.8

ECONOMIC VERSIONS; RELEVANT PHYSICAL DIMENSIONS

TYPE OF HEAD	H_{max} (mm)	W_{max} (mm)	L_{max} (mm)
Round	7.7	5.5	7.3



MOUNTING

The trimmer has a lead pitch of 5.08 mm or 5.6 mm and can be mounted on printed-circuit boards with a minimum hole diameter of 1.25 mm.

PACKAGING

Bulk packaged in cardboard boxes lined with expanded plastic, 1000 units per box.

ORDERING INFORMATION

C _{min} /C _{max} (pF)	CATALOG NUMBER BFC2 808		
	TOP AND BOTTOM ADJUSTMENT (P = 5.6 mm)	TOP ADJUSTMENT ONLY (P = 5.6 mm)	TOP ADJUSTMENT ONLY (P = 5.08 mm)
STANDARD VERSIONS: POLYTETRAFLUORETHYLENE, ROUND HEAD			
0.35/1.5	22158	-	-
STANDARD VERSIONS: POLYPROPYLENE, ROUND HEAD			
1.2/5	-	24508	-
1.5/5	23508	-	20508
1.5/7	-	24708	-
3/10	23109	-	20109
3/15	23159	-	20159
4/20	23209	-	20209
4/27	23279	-	20279
ECONOMIC VERSIONS: POLYCARBONATE, ROUND HEAD			
1.5/7	-	20126	-
1.6/15	-	20127	-
3/20	-	20123	-
3.5/27	-	20128	-

ELECTRICAL DATA STANDARD VERSIONS WITH ROUND HEAD

GUARANTEED MAX. C _{min} / MIN. C _{max} AT 200 KHz (pF)	TAN δ AT C _{max} x 10 ⁻⁴		TEMP. COEFF. ¹⁾ (10 ⁻⁶ /K)	MIN. f _{res} AT C _{max} (MHz)	COLOUR OF BASE	SMALLEST PACKAGING QUANTITY	CATALOG NUMBER BFC2
	1 MHz	100 MHz					
0.35/1.5	≤ 10	-	- 450 ± 550	-	-	1000 808 22158
1.2/5	≤ 10	-	- 200 ± 550	-	grey	1000 808 24508
1.5/5	≤ 10	≤ 25	- 200 ± 550	700	grey	1000 808 20508
						 808 23508
1.5/7	≤ 10	-	- 50 ± 550	-	grey	1000 808 24708
3/10	≤ 10	≤ 25	- 250 ± 550	500	yellow	1000 808 20109
						 808 23109
3/15	≤ 10	≤ 25	- 250 ± 550	400	blue	1000 808 20159
						 808 23159
4/20	≤ 10	≤ 25	- 250 ± 400	300	green	1000 808 20209
						 808 23209
4/27	≤ 10	≤ 25	- 250 ± 400	300	red	1000 808 20279
						 808 23279

Note:

1. C: 60 % to 80 % of C_{max}; T_{amb}: from + 20 °C to + 70 °C

ECONOMIC VERSIONS WITH ROUND HEAD

REFERENCE C_{min}/C_{max} (pF)	TAN δ AT $C_{max} \times 10^{-4}$ (1 MHz)	TEMP. COEFF. ($10^{-6}/K$)	COLOUR OF BASE	SMALLEST PACKAGING QUANTITY	CATALOG NUMBER BFC2
1.5/7	≤ 70	- 50 \pm 550	grey	1000	... 808 20126
1.6/15	≤ 70	- 50 \pm 550	blue	1000	... 808 20127
3/20	≤ 70	- 50 \pm 550	green	1000	... 808 20123
3.5/27	≤ 70	- 100 \pm 400	red	1000	... 808 20128

TEST PROCEDURES AND REQUIREMENTS

IEC 60418-1 CLAUSE	IEC 60068 TEST METHOD	TEST	PROCEDURE	REQUIREMENTS
4.2		method of mounting	method A	
14		capacitance drift	after TC measurement	$\Delta C/C: \leq 3\%$ for $C_{max} \leq 10$ pF $\Delta C/C: \leq 2\%$ for $C_{max} > 10$ pF
19		thrust	axial thrust of 2 N	$\Delta C/C: \leq 0.4\%$
21		robustness of terminations:		
21.1	Ua	tensile	1 N	no damage
21.2	Ub	bending	1 cycle	no damage
22	Na	rapid change of temperature	1 cycle; 0.5 hours at lower and 0.5 hours at upper category temperature	$\Delta C/C: \leq 2.5\%$
23	T	soldering:		
	Ta	solderability	solder bath immersion 3 mm; 235 °C; 2 s	good wetting no mechanical damage
	Tb	resistance to heat	solder bath: 260 °C; 10 s	no mechanical damage
24	Eb	impact bump	4000 \pm 10 bumps; 40 g; 6 ms	$\Delta C/C: \leq 1\%$; no mechanical damage
25	Fc	vibration	frequency 10 to 55 Hz; amplitude 0.75 mm; 1.5 hours	$\Delta C/C: \leq 1\%$; no mechanical damage
26		climatic sequence:		$\Delta C/C: \leq 4\%$
26.1	B	dry heat	16 hours at upper category temperature	$\tan \delta$ or PP and PTFE foil: $\leq 15 \times 10^{-4}$ $\tan \delta$ for PC foil: $\leq 80 \times 10^{-4}$ $R_{ins}: \geq 10\,000$ M Ω rotor contact R: ≤ 10 m Ω
26.2	D	damp heat accelerated, first cycle	1 cycle; 24 hours; + 40 °C; 95 to 100 % RH	voltage proof: 300 V for 1 minute
26.3	Aa	cold	16 hours; - 40 °C	visual examination: no mechanical damage
26.5		damp heat accelerated, remaining cycles	1 cycle; 24 hours; + 40 °C; 95 to 100% RH	operating torque: 1 to 20 mNm for $C_{max} < 20$ pF; 1 to 30 mNm for $C_{max} \geq 20$ pF



IEC 60418-1 CLAUSE	IEC 60068 TEST METHOD	TEST	PROCEDURE	REQUIREMENTS
27	Ca	damp heat steady state	21 days; + 40 °C; 90 to 95 % RH	$\Delta C/C: \leq 3 \%$ tan δ for PP and PTFE foil: $\leq 15 \times 10^{-4}$; tan δ for PC foil: $\leq 80 \times 10^{-4}$ $R_{ins}: \geq 10\,000 \text{ M}\Omega$; rotor contact R: $\leq 10 \text{ m}\Omega$ voltage proof: 300 V for 1 minute visual examination: no mechanical damage operating torque: 1 to 20 mNm for $C_{max} < 20 \text{ pF}$; 1 to 30 mNm for $C_{max} \geq 20 \text{ pF}$
29		mechanical endurance	10 cycles Maximum 10 cycles: rotation in 180° only. (The electrical and mechanical performance is not guaranteed if rotated beyond 10 cycles)	$\Delta C/C: \leq 3 \%$ $\Delta C/C$ after axial thrust: $\leq 0.3 \%$; rotor contact R: $\leq 10 \text{ m}\Omega$ voltage proof: 300 V for 1 minute visual examination: no mechanical damage operating torque: 0.5 to 22.5 mNm for $C_{max} < 20 \text{ pF}$; 0.5 to 30 mNm for $C_{max} \geq 20 \text{ pF}$



Disclaimer

ALL PRODUCT, PRODUCT SPECIFICATIONS AND DATA ARE SUBJECT TO CHANGE WITHOUT NOTICE TO IMPROVE RELIABILITY, FUNCTION OR DESIGN OR OTHERWISE.

Vishay Intertechnology, Inc., its affiliates, agents, and employees, and all persons acting on its or their behalf (collectively, "Vishay"), disclaim any and all liability for any errors, inaccuracies or incompleteness contained in any datasheet or in any other disclosure relating to any product.

Vishay makes no warranty, representation or guarantee regarding the suitability of the products for any particular purpose or the continuing production of any product. To the maximum extent permitted by applicable law, Vishay disclaims (i) any and all liability arising out of the application or use of any product, (ii) any and all liability, including without limitation special, consequential or incidental damages, and (iii) any and all implied warranties, including warranties of fitness for particular purpose, non-infringement and merchantability.

Statements regarding the suitability of products for certain types of applications are based on Vishay's knowledge of typical requirements that are often placed on Vishay products in generic applications. Such statements are not binding statements about the suitability of products for a particular application. It is the customer's responsibility to validate that a particular product with the properties described in the product specification is suitable for use in a particular application. Parameters provided in datasheets and/or specifications may vary in different applications and performance may vary over time. All operating parameters, including typical parameters, must be validated for each customer application by the customer's technical experts. Product specifications do not expand or otherwise modify Vishay's terms and conditions of purchase, including but not limited to the warranty expressed therein.

Except as expressly indicated in writing, Vishay products are not designed for use in medical, life-saving, or life-sustaining applications or for any other application in which the failure of the Vishay product could result in personal injury or death. Customers using or selling Vishay products not expressly indicated for use in such applications do so at their own risk and agree to fully indemnify and hold Vishay and its distributors harmless from and against any and all claims, liabilities, expenses and damages arising or resulting in connection with such use or sale, including attorneys fees, even if such claim alleges that Vishay or its distributor was negligent regarding the design or manufacture of the part. Please contact authorized Vishay personnel to obtain written terms and conditions regarding products designed for such applications.

No license, express or implied, by estoppel or otherwise, to any intellectual property rights is granted by this document or by any conduct of Vishay. Product names and markings noted herein may be trademarks of their respective owners.