

Film Dielectric Trimmers



FEATURES

- High temperature type
- Housing dimensions:
6 mm x 8 mm x 9 mm
- For a basic grid of 2.54 mm
- Top and bottom adjustment
- Round head
- Mounting: radial
- Material categorization: for definitions of compliance please see www.vishay.com/doc?99912

RoHS
COMPLIANT

APPLICATIONS

- Antennas
- Impedance matching circuits
- Medical
- RF
- For fine adjustment in professional applications

QUICK REFERENCE DATA		
Rated DC voltage	300 V _{DC}	
Test DC voltage for 1 min	600 V _{DC}	
Maximum contact resistance	5 mΩ	
Minimum insulation resistance between stator and rotor	10 000 MΩ	
Category temperature range	-40 °C to +125 °C	
Climatic category (IEC 60068)	40/125/21	
Minimum storage temperature	-55 °C	
Related specification	IEC 60418-1 and 4	
Effective angle of rotation	180° (rotation in 180° only, see "Life of trimmer")	
Operating torque	C _{max.} < 3.5 pF	1 mNm to 15 mNm
	C _{max.} ≥ 3.5 pF	1 mNm to 20 mNm
Maximum axial thrust	2 N	
Capacitance range (C _{min.} / C _{max.})	1.2 pF / 3.5 pF to 2 pF / 18 pF	
Life of trimmer	Maximum 10 cycles: rotation in 180° only (the electrical and mechanical performance is not guaranteed if rotated beyond 10 cycles)	
Quality level	Sampling and data evaluation for quality level in accordance with "MIL-STD-105D" and "IEC 60410": < 0.15 % major defects < 0.65 % minor defects Each capacitor is tested for minimum C _{max.} and is also subjected to the full test voltage.	

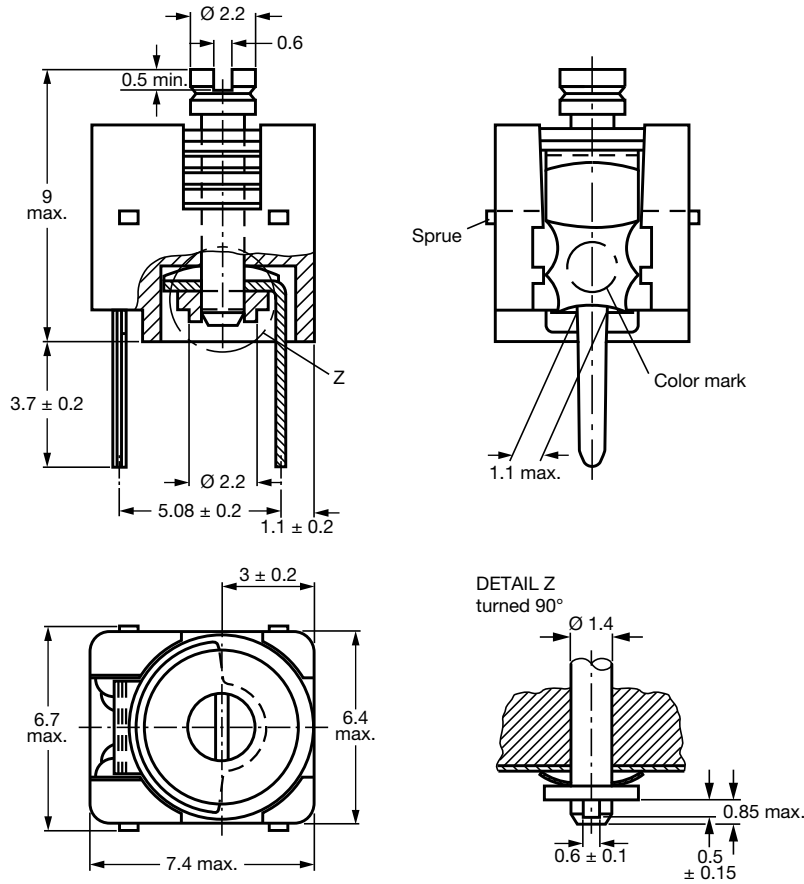
DIMENSIONS in millimeters

Trimmers BFC2 809 05... series, with round heads

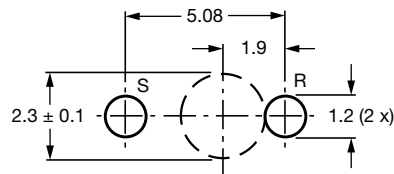

Hole pattern

ADJUSTMENT

For top adjustment a screwdriver or trimming key can be used; for bottom adjustment a key is required as shown below.

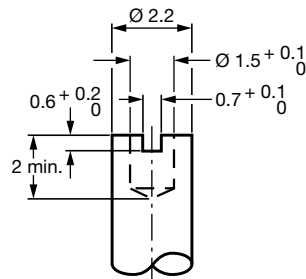

Bottom adjustment key



ORDERING INFORMATION			
C _{min.} / C _{max.} (pF)	CATALOG NUMBER BFC2 809 05...		
	TOP AND BOTTOM ADJUSTMENT		
	ROUND HEAD	ROUND HEAD AND FLUX GUARD	
1.2 / 3.5	215	001	
1.8 / 10	216	002	
2 / 18	217	003	

MOUNTING

The trimmer can be mounted on printed-circuit boards with a minimum hole diameter of 2.54 mm.

PACKAGING

Blister packs of 70 units each. For smallest packaging quantity (SPQ) see "Electrical Data" table.

ELECTRICAL DATA									
GUARANTEED MAX. C _{min.} / MIN. C _{max.} AT 200 kHz (pF)	SHAPE OF HEAD	FIG.	tan δ AT C _{max.} x 10 ⁻⁴		TEMP. COEFF. ⁽¹⁾ (10 ⁻⁶ /K)	MIN. f _{res} AT C _{max.} (MHz)	COL. OF DOT	SPQ	CATALOG NUMBER BFC2
			1 MHz	100 MHz					
1.2 / 3.5	Round	1	≤ 10	≤ 20	-250 ± 350	850	Orange	700 809 05001
								700 809 05215
1.8 / 10	Round	1	≤ 10	≤ 20	-250 ± 350	1200	None	700 809 05002
								580 809 05216
2 / 18	Round	1	≤ 10	≤ 25	-250 ± 350	360	Red	700 809 05217
								700 809 05003

Note

⁽¹⁾ C: 60 % to 80 % of C_{max.}; T_{amb.}: from +20 °C to +125 °C

SOLDERING CONDITIONS

For general soldering conditions and wave soldering profile, we refer to the application note "Soldering Guidelines for Film Capacitors": www.vishay.com/doc?28171

TEST PROCEDURES AND REQUIREMENTS				
IEC 60418-1 CLAUSE	IEC 60068 TEST METHOD	TEST	PROCEDURE	REQUIREMENTS
4.2		Method of mounting	Method A	
14		Capacitance drift	After TC measurement	ΔC/C: ≤ 2.5 %; 4 % for 2 pF
19		Thrust	Axial thrust of 2 N	ΔC/C: ≤ 0.3 %
21		Robustness of terminations:		
21.1	Ua	Tensile	1 N	No damage
21.2	Ub	Bending	1 cycle	No damage
22	Na	Rapid change of temperature	1 cycle; 0.5 h at lower and 0.5 h at upper category temperature	ΔC/C: ≤ 2.5 %
23	T	Soldering:		
	Ta	Solderability	Solder bath immersion 3 mm; 235 °C; 2 s	Good wetting, no mechanical damage
	Tb	Resistance to heat	Solder bath: 260 °C; 10 s	No mechanical damage



TEST PROCEDURES AND REQUIREMENTS					
IEC 60418-1 CLAUSE	IEC 60068 TEST METHOD	TEST	PROCEDURE	REQUIREMENTS	
24	Eb	Impact bump	4000 ± 10 bumps; 40 g; 6 ms	$\Delta C/C: \leq 0.6 \%$; no mechanical damage	
25	Fc	Vibration	Frequency 10 Hz to 55 Hz; amplitude 0.35 mm; 1.5 h	$\Delta C/C: \leq 0.6 \%$; no mechanical damage	
26	B	Climatic sequence:		$\Delta C/C: \leq 2.5$	
26.1		Dry heat	16 h at upper category temperature	$\tan \delta: \leq 10 \times 10^{-4}$ for $C_{max.} < 18 \text{ pF}$; $\tan \delta: \leq 40 \times 10^{-4}$ for $C_{max.} \geq 18 \text{ pF}$ $R_{ins.}: \geq 10\,000 \text{ M}\Omega$; rotor contact R: $\leq 5 \text{ m}\Omega$	
26.2		Damp heat accelerated, first cycle	1 cycle; 24 h; +40 °C; 95 % to 100 % RH	Voltage proof: 600 V for 1 min	
26.3		Aa	Cold	16 h; -40 °C	Visual examination: no mechanical damage
26.5		Damp heat accelerated, remaining cycles	1 cycle; 24 h; +40 °C; 95 % to 100 % RH	Operating torque: 1 mNm to 20 mNm	
27	Ca	Damp heat steady state	21 days; +40 °C; 90 % to 95 % RH	$\Delta C/C: \leq 2.5 \%$ $\tan \delta: \leq 10 \times 10^{-4}$ for $C_{max.} < 18 \text{ pF}$; $\tan \delta: \leq 25 \times 10^{-4}$ for $C_{max.} \geq 18 \text{ pF}$ $R_{ins.}: \geq 10\,000 \text{ M}\Omega$; rotor contact R: $\leq 5 \text{ m}\Omega$ Voltage proof: 600 V for 1 min Visual examination: no mechanical damage Operating torque: 1 mNm to 20 mNm	
29		Mechanical endurance	10 cycles Maximum 10 cycles: rotation in 180° only (the electrical and mechanical performance is not guaranteed if rotated beyond 10 cycles)	$\Delta C/C: \leq 0.3 \%$; $\leq 2.5 \%$ for 2 pF $\Delta C/C$ after axial thrust: $\leq 0.3 \%$; rotor contact R: $\leq 5 \text{ m}\Omega$ Voltage proof: 600 V for 1 min Visual examination: no mechanical damage Operating torque: 1 mNm to 20 mNm	



Disclaimer

ALL PRODUCT, PRODUCT SPECIFICATIONS AND DATA ARE SUBJECT TO CHANGE WITHOUT NOTICE TO IMPROVE RELIABILITY, FUNCTION OR DESIGN OR OTHERWISE.

Vishay Intertechnology, Inc., its affiliates, agents, and employees, and all persons acting on its or their behalf (collectively, "Vishay"), disclaim any and all liability for any errors, inaccuracies or incompleteness contained in any datasheet or in any other disclosure relating to any product.

Vishay makes no warranty, representation or guarantee regarding the suitability of the products for any particular purpose or the continuing production of any product. To the maximum extent permitted by applicable law, Vishay disclaims (i) any and all liability arising out of the application or use of any product, (ii) any and all liability, including without limitation special, consequential or incidental damages, and (iii) any and all implied warranties, including warranties of fitness for particular purpose, non-infringement and merchantability.

Statements regarding the suitability of products for certain types of applications are based on Vishay's knowledge of typical requirements that are often placed on Vishay products in generic applications. Such statements are not binding statements about the suitability of products for a particular application. It is the customer's responsibility to validate that a particular product with the properties described in the product specification is suitable for use in a particular application. Parameters provided in datasheets and / or specifications may vary in different applications and performance may vary over time. All operating parameters, including typical parameters, must be validated for each customer application by the customer's technical experts. Product specifications do not expand or otherwise modify Vishay's terms and conditions of purchase, including but not limited to the warranty expressed therein.

Except as expressly indicated in writing, Vishay products are not designed for use in medical, life-saving, or life-sustaining applications or for any other application in which the failure of the Vishay product could result in personal injury or death. Customers using or selling Vishay products not expressly indicated for use in such applications do so at their own risk. Please contact authorized Vishay personnel to obtain written terms and conditions regarding products designed for such applications.

No license, express or implied, by estoppel or otherwise, to any intellectual property rights is granted by this document or by any conduct of Vishay. Product names and markings noted herein may be trademarks of their respective owners.