

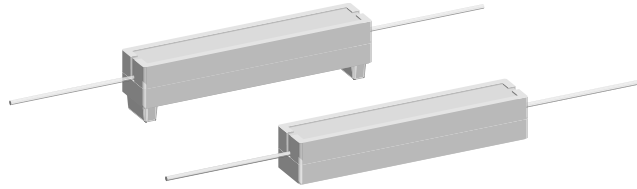

Wirewound/Metal Film Resistors, Commercial Power, Axial Lead



FEATURES

- High power dissipation in small volume
- Ideal for pulsing applications
- Completely welded construction
- Non-flammable
- High heat and moisture resistance
- Low inductance version available on request



RoHS
COMPLIANT

Please reference the Vishay Dale closest equivalents: CP, CP High Volume (for CP datasheet please visit our website: <http://www.vishay.com/doc?30213> and for CP High Volume datasheet: <http://www.vishay.com/doc?30113>).

Note:

- There may be slight differences between the Vishay Phoenix and the Vishay Dale crosses

TECHNOLOGY

AMW: The resistor element is a resistive wire, which is wound on a ceramic rod.

AMF: The resistive element is a metal film resistor consisting of a metal layer deposited over a high grade ceramic rod.

For both AMW and AMF, tinned copper leads are connected to the caps by welding. The resistor body is housed in a rectangular ceramic case with a special, inorganic potting which is non-flammable, will not melt even at high overloads and is resistant to most commonly used cleaning solvents.

STANDARD ELECTRICAL SPECIFICATIONS				
MODEL	POWER RATING $P_{40^\circ\text{C}}$ W	RESISTANCE RANGE ⁽¹⁾ Ω	TOLERANCE ⁽²⁾ %	E-SERIES Decade Values
AMW03	3	0.1 - 2.0K	± 5	24
AMF03		100 - 39K		
AMW05	5	0.1 - 4.7K		
AMF05		100 - 51K		
AMW07	7	0.1 - 6.2K		
AMF07		100 - 51K		
AMW10	10	0.1 - 10K		
AMF10		1K - 100K		
AMW15	15 at 25 °C	0.1 - 10K		
AMW20	20 at 25 °C	0.1 - 15K		

Notes:

⁽¹⁾ Special resistance values available upon request

⁽²⁾ Other tolerances available upon request

TECHNICAL SPECIFICATIONS						
PARAMETER	UNIT	AMW	AMF03	AMF05	AMF07	AMF10
Limiting Voltage	V	$\sqrt{P \times R}$	750	1000	1200	1500
Insulation Voltage	V	> 2000				
Temperature Coefficient ⁽³⁾	ppm/°C	R < 10 Ω : 0 to 600; R ≥ 10 Ω : - 100 to + 150;	± 250			
Operating Temperature	°C	- 55 to + 275				
Short Time Overload	-	5 x rated power for 5 s				

Note:

⁽³⁾ Temperature Coefficient of ± 30, 50 or 90 ppm/°C available on AMW upon request



DIMENSIONS in millimeters (inches)						
<p>FLAT VERSION</p> <p>STAND-OFF VERSION</p>						
TYPE	A	H	B	E	Ød	L (1)
AMW03 AMF03	22.2 ± 1.5 (0.87 ± 0.06)	8.0 ± 1.0 (0.32 ± 0.04)	8.0 ± 1.0 (0.32 ± 0.04)	9.5 ± 1.0 (0.374 ± 0.04)	0.80 ± 0.03 (0.031 ± 0.001)	28.0 ± 2.5 (1.11 ± 0.098)
AMW05 AMF05	22.2 ± 1.5 (0.87 ± 0.06)	9.5 ± 1.0 (0.37 ± 0.04)	9.5 ± 1.0 (0.37 ± 0.04)	11 ± 1.0 (0.433 ± 0.04)		
AMW07 AMF07	35 ± 1.5 (1.38 ± 0.059)	9.5 ± 1.0 (0.37 ± 0.04)	9.5 ± 1.0 (0.37 ± 0.04)	11.9 ± 1.0 (0.469 ± 0.04)		
AMW10 AMF10	48 ± 2 (1.89 ± 0.079)	9.5 ± 1.0 (0.37 ± 0.04)	9.5 ± 1.0 (0.37 ± 0.04)	11.9 ± 1.0 (0.469 ± 0.04)		
AMW15	48 ± 2 (1.89 ± 0.079)	12.5 ± 1.0 (0.49 ± 0.04)	12.5 ± 1.0 (0.49 ± 0.04)	15.9 ± 1.0 (0.626 ± 0.04)		
AMW20	63.5 ± 2 (2.5 ± 0.079)	12.5 ± 1.0 (0.49 ± 0.04)	12.5 ± 1.0 (0.49 ± 0.04)	15.9 ± 1.0 (0.626 ± 0.04)		

Note:

(1) Long leads (38.1 mm) available on request

ELECTRICAL CHARACTERISTICS

The power that the resistor can dissipate depends on the operating temperature.

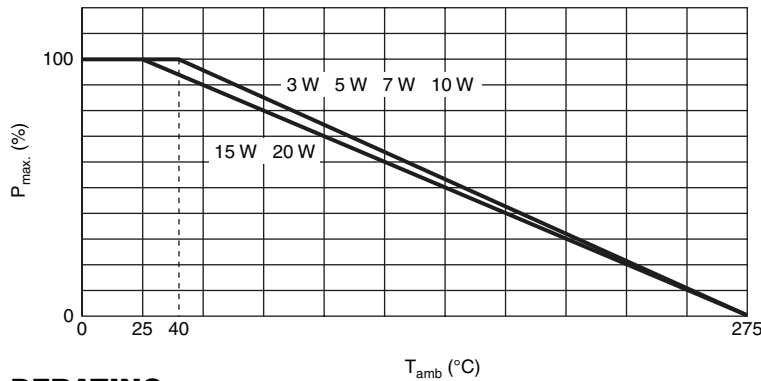

DERATING

Maximum dissipation (P_{max}) in percentage of rated power as a function of ambient temperature (T_{amb})

Notes:

Application information available on request:

- Pulse load behavior
- High frequency behavior (self inductance)
- Hot spot and solder spot curves



MARKING

The resistor is marked with the resistor type, the rated power, the nominal resistance value (R for values Ω and K for values k Ω), the tolerance and the production date (week and year) in red on the resistor body.

Example:

PHX	AMW07	212
5K1	5 %	7 W

Example: AMW07 - 5.1 k Ω - 5 % - year 2002 - week 12

ORDERING INFORMATION						
PRODUCT	TOLERANCE	ORDERING CODE	VERSION	LEAD \varnothing in millimeters (inches)	PACKAGING	QUANTITY (pieces)
AMW03	$\pm 5 \%$	2306 350 13xxx	FLAT	0.80 (0.031)	BOX	250
		2306 350 23xxx	STAND-OFF			
AMF03		2306 356 13xxx	FLAT			
		2306 356 23xxx	STAND-OFF			
AMW05		2306 351 13xxx	FLAT			
		2306 351 23xxx	STAND-OFF			
AMF05		2306 357 13xxx	FLAT			
		2306 357 23xxx	STAND-OFF			
AMW07		2306 352 13xxx	FLAT			
		2306 352 23xxx	STAND-OFF			
AMF07		2306 358 13xxx	FLAT			
		2306 358 23xxx	STAND-OFF			
AMW10		2306 353 13xxx	FLAT			
		2306 353 23xxx	STAND-OFF			
AMF10		2306 359 13xxx	FLAT			
		2306 359 23xxx	STAND-OFF			
AMW15		2306 354 13xxx	FLAT			
		2306 354 23xxx	STAND-OFF			
AMW20		2306 355 13xxx	FLAT			
		2306 355 23xxx	STAND-OFF			
						100

Last Digit of Ordering Code

RESISTANCE DECADE	LAST DIGIT
0.1 - 0.91 Ω	7
1 - 9.1 Ω	8
10 - 91 Ω	9
100 - 910 Ω	1
1 - 9.1 k Ω	2
10 - 91 k Ω	3
100 - 910 k Ω	4

The resistors have 12 digit ordering code starting with 2306. The next 5 digits indicate the resistor type and packaging, see table ORDERING INFORMATION.

The last 3 digits indicate the resistance value:

- The first 2 digits of these last 3 indicate the actual resistance value
- The last digit indicates the resistance decade in accordance with table "Last Digit of Ordering Code"

Example:

AMW05, 47 Ω , $\pm 5 \%$, flat case, box of 250 pieces is **230635113479**



NAFTA ORDERING INFORMATION						
PRODUCT	TOLERANCE	NAFTA ORDERING CODE	VERSION	LEAD Ø in millimeters (inches)	PACKAGING	QUANTITY (pieces)
AMW03	± 5 %	AMW03WxxxxxJ	FLAT	0.80 (0.031)	BOX	250
		AMW03WxxxxxJSO	STAND-OFF			
AMF03		AMF03WxxxxxJ	FLAT			
		AMF03WxxxxxJSO	STAND-OFF			
AMW05		AMW05WxxxxxJ	FLAT			
		AMW05WxxxxxJSO	STAND-OFF			
AMF05		AMF05WxxxxxJ	FLAT			
		AMF05WxxxxxJSO	STAND-OFF			
AMW07		AMW07WxxxxxJ	FLAT			
		AMW07WxxxxxJSO	STAND-OFF			
AMF07		AMF07WxxxxxJ	FLAT			
		AMF07WxxxxxJSO	STAND-OFF			
AMW10		AMW10WxxxxxJ	FLAT			
		AMW10WxxxxxJSO	STAND-OFF			
AMF10		AMF10WxxxxxJ	FLAT			
		AMF10WxxxxxJSO	STAND-OFF			
AMW15		AMW15WxxxxxJ	FLAT			
		AMW15WxxxxxJSO	STAND-OFF			
AMW20		AMW20WxxxxxJ	FLAT			
		AMW20WxxxxxJSO	STAND-OFF			
						100

Examples of the Ohmic Value

Value	5 DIGITS
1 Ω	1R000
10 Ω	10R00
100 Ω	100R0
1 kΩ	1K000
10 kΩ	10K00
100 kΩ	100K0

The ohmic value in the NAFTA ordering code (see table NAFTA ORDERING INFORMATION) is represented by the “xxxxx” in the middle of the above ordering code. The table “Examples of the Ohmic Value” gives some examples on how to use these 5 digits.

Example:
AMW03, 47 Ω, ± 5 %, flat case, box of 250 pieces is **230635113479**



PACKAGING in millimeters (inches)

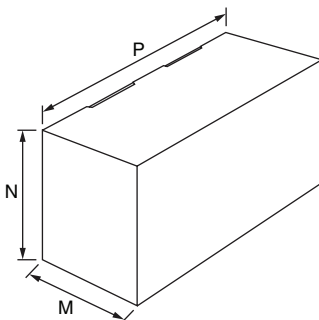

PRODUCT	VERSION	P	M	N	QUANTITY (pieces)	
AMW03 AMF03	FLAT	227 (8.94)	92 (3.62)	100 (3.94)	250	
	STAND-OFF	227 (8.94)	92 (3.62)	-		
AMW05 AMF05	FLAT	256 (10.08)	92 (3.62)	105 (4.13)		
	STAND-OFF	256 (10.08)	92 (3.62)	-		
AMW07 AMF07	FLAT	256 (10.08)	105 (4.13)	105 (4.13)		
	STAND-OFF	256 (10.08)	105 (4.13)	-		
AMW10 AMF10	FLAT	256 (10.08)	118 (4.65)	105 (4.13)		
	STAND-OFF	256 (10.08)	118 (4.65)	-		
AMW15	FLAT	264 (10.39)	119 (4.69)	72 (2.83)		100
	STAND-OFF	264 (10.39)	119 (4.69)	-		
AMW20	FLAT	264 (10.39)	135 (5.32)	72 (2.83)		
	STAND-OFF	264 (10.39)	135 (5.32)	-		



TESTS AND REQUIREMENTS

Essentially all tests are carried out in accordance to the schedule of IEC publications 60115-1, category 65/275/56 (rated temperature range - 65 °C to + 275 °C; damp heat, long term, 56 days and along the lines of IEC publications 60068-2); "Recommended basic climatic and mechanical robustness testing procedure for electronic components" and under standard atmosphere conditions according to IEC 60068-1 subclause 5.3, unless otherwise specified. In some instances deviations from IEC applications were necessary for our method specified.

PERFORMANCE				
IEC 60115-1 CLAUSE	IEC 60068-2 TEST METHOD	TEST	PROCEDURE	REQUIREMENTS
4.6.1.1		Insulation resistance	500 V _{DC} during 1 min; V-block method	R _{ins min} 100 MΩ
4.7		Voltage proof on insulation	1000 V _{RMS} during 1 min; V-block method	No breakdown or flashover
4.8		Temperature coefficient	Between - 55 °C at + 275 °C AMW R < 10 Ω R ≥ 10 Ω AMF	0 to 600 ppm/°C; - 100 to 150 ppm/°C ± 250 ppm/°C
4.13		Short time overload	Dissipation 5 x P _n ; 5 s, V _{max} for: AMF03 ≤ 1500 V AMF05 ≤ 2000 V AMF07 ≤ 2500 V AMF10 ≤ 3000 V	ΔR/R _{max} ± 4 % + 0.05 Ω
4.16	21(U)	Robustness of terminations:		
4.16.2	21(Ua1)	Tensile all samples	Load 10 N; 10 s	No visible damage
4.16.3	21(Ub)	Bending half number of samples	Load 5 N; 4 x 90°	ΔR/R _{max} ± 2 % + 0.05 Ω
4.16.4	21(Uc)	Tension other half of samples	3 x 360° in opposite directions	
4.17	20(Ta)	Solderability (after aging)	16 h at 155 °C; leads immersed in flux 600, leads immersed 2 mm for 2 ± 0.5 s in a solder bath at 235 ± 5 °C	Good tinning; no damage ΔR/R _{max} ± 0.5 % + 0.05 Ω
4.18	20(Tb)	Resistance to soldering heat	Thermal shock: 3 s, 350 °C; 6 mm from body	ΔR/R _{max} ± 4 % + 0.05 Ω
4.19	14(Na)	Rapid change of temperature	30 min at - 55 °C and 30 min + 275 °C; 5 cycles	No visual damage ΔR/R _{max} ± 5 % + 0.05 Ω
4.23		Climatic sequence:		
4.23.2	2(Ba)	Dry heat	16 h, 275 °C	
4.23.3	30(Db)	Damp heat (accelerated) 1st cycle	24 h, 25 °C to 55 °C; 90 to 100 % RH	ΔR/R _{max} ± 3 % + 0.05 Ω
4.23.4	1(Aa)	Cold	2 h, - 65 °C	
4.23.6	30 (Db)	Damp heat (accelerated) remaining cycles	6 days; 55 °C; 90 to 98 % RH	
4.24	3 (Ca)	Damp heat (steady state)	56 days; 40 °C; 90 to 95 % RH; loaded with 0.01 P _n	ΔR/R _{max} ± 3 % + 0.05 Ω
4.25.1		Endurance (at 40 °C)	1000 h loaded with P _n or V _{max} ; 1.5 h ON and 0.5 h OFF	No damage ΔR/R _{max} ± 5 % + 0.1 Ω



Disclaimer

ALL PRODUCT, PRODUCT SPECIFICATIONS AND DATA ARE SUBJECT TO CHANGE WITHOUT NOTICE TO IMPROVE RELIABILITY, FUNCTION OR DESIGN OR OTHERWISE.

Vishay Intertechnology, Inc., its affiliates, agents, and employees, and all persons acting on its or their behalf (collectively, "Vishay"), disclaim any and all liability for any errors, inaccuracies or incompleteness contained in any datasheet or in any other disclosure relating to any product.

Vishay makes no warranty, representation or guarantee regarding the suitability of the products for any particular purpose or the continuing production of any product. To the maximum extent permitted by applicable law, Vishay disclaims (i) any and all liability arising out of the application or use of any product, (ii) any and all liability, including without limitation special, consequential or incidental damages, and (iii) any and all implied warranties, including warranties of fitness for particular purpose, non-infringement and merchantability.

Statements regarding the suitability of products for certain types of applications are based on Vishay's knowledge of typical requirements that are often placed on Vishay products in generic applications. Such statements are not binding statements about the suitability of products for a particular application. It is the customer's responsibility to validate that a particular product with the properties described in the product specification is suitable for use in a particular application. Parameters provided in datasheets and / or specifications may vary in different applications and performance may vary over time. All operating parameters, including typical parameters, must be validated for each customer application by the customer's technical experts. Product specifications do not expand or otherwise modify Vishay's terms and conditions of purchase, including but not limited to the warranty expressed therein.

Hyperlinks included in this datasheet may direct users to third-party websites. These links are provided as a convenience and for informational purposes only. Inclusion of these hyperlinks does not constitute an endorsement or an approval by Vishay of any of the products, services or opinions of the corporation, organization or individual associated with the third-party website. Vishay disclaims any and all liability and bears no responsibility for the accuracy, legality or content of the third-party website or for that of subsequent links.

Vishay products are not designed for use in life-saving or life-sustaining applications or any application in which the failure of the Vishay product could result in personal injury or death unless specifically qualified in writing by Vishay. Customers using or selling Vishay products not expressly indicated for use in such applications do so at their own risk. Please contact authorized Vishay personnel to obtain written terms and conditions regarding products designed for such applications.

No license, express or implied, by estoppel or otherwise, to any intellectual property rights is granted by this document or by any conduct of Vishay. Product names and markings noted herein may be trademarks of their respective owners.