

## Transformers Pulse, Trigger Type

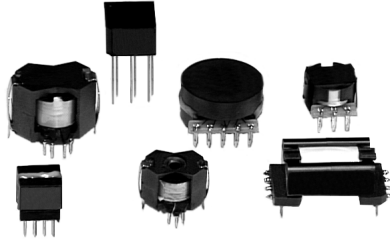

### FEATURES

- Integrated Services Digital Network transformers that provide isolation for the line card and terminal in conjunction with both "S/T" and "U" interfaces.
- Designed to meet the CCITT 1.430 pulse wave form template requirements.
- Isolation voltage levels available for U.S. and international applications.
- Printed circuit board mountable in both through-hole and surface mount packages..
- Standard and custom configurations available.
- PT-100 series used for "S/T" interfaces.
- PT-200 series used for "U" interfaces.



**RoHS**  
COMPLIANT

### STANDARD ELECTRICAL SPECIFICATIONS

MODEL	TURNS RATIO	PRIMARY INDUCTANCE MIN. (MH)	PRIMARY DCR MAX. (Ohms)	SECONDARY DCR MAX. (Ohms)	LEAKAGE INDUCTANCE MAX. (μH)	PRIMARY/SECONDARY HIPOT (V RMS)	STYLE NUMBER	SCHEMATIC NUMBER
PT-100-01	1 CT : 2 CT	20	1.2	11.0	30	1500	1	1
PT-100-02	1 CT : 2 CT	20	1.2	11.0	30	1500	2	2
PT-100-04	1 CT : 2 CT	20	3.0	4.5	15	1500	4	4
PT-100-05	1 CT : 2.5 CT	22	2.8	6.5	20	1500	1	1
PT-100-06	1 CT : 1 CT	22	2.8	2.8	10	1500	5	6
PT-100-08	1 CT : 1.8 CT	22	2.8	5.5	20	1500	1	1
PT-100-09	1 CT : 2 CT	22	8.0	15.0	30	1500	7	5
PT-100-012	1 CT : 2 CT	22	2.8	5.5	10	2000	9	4
PT-200-01	2.5 : 1	72	8.5	2.0	160	1100	3	3
PT-200-02	2 : 1 CT	25	11.0	3.5	20	1100	6	7
PT-200-03	2 : 1	30	2.3	2.0	200	1100	8	8
PT-200-08	1.6 : 1	13	3.0	3.0	55	2000	6	9

### TRANSFORMER CROSS REFERENCE FOR TRANSCEIVER CHIPS

MODEL	TURNS RATIO	IC MANUFACTURER	IC PART NUMBER
PT-100-01	1 CT : 2 CT	SIEMENS	PEB2080/2085/2081
PT-100-02	1 CT : 2 CT	SIEMENS	PEB2080/2085/2081
PT-100-04	1 CT : 2 CT	AMD	79C30A
		MITEL	MT8930
		NATIONAL	TP3420
PT-100-05	1 CT : 2.5 CT	INTEL	29C53
		AT&T	T7250/T7252
PT-100-06	1 CT : 1 CT	MOTOROLA	MC145474
			MC145475
PT-100-08	1 CT : 1.8 CT	INTEL	29C53
PT-100-09	1 CT : 2 CT	SIEMENS	PEB2080/2085
		AMD	79C30A
		MITEL	MT8930
		NATIONAL	TP3420
PT-100-012*	1 CT : 2 CT	SIEMENS	PEB2080/2085/2081
		AMD	79C30A
		MITEL	MT8930
		NATIONAL	TP3420
PT-200-01	2.5 : 1	AT&T	T7262/T7263
PT-200-02	2 : 1 CT	MOTOROLA	MC145472
PT-200-03	2 : 1	MITEL	MT8972
PT-200-08*	1.6 : 1**	SIEMENS	PEB2091

\*Hipot voltage will meet international safety standards. \*\*Low profile.

### SCHEMATICS

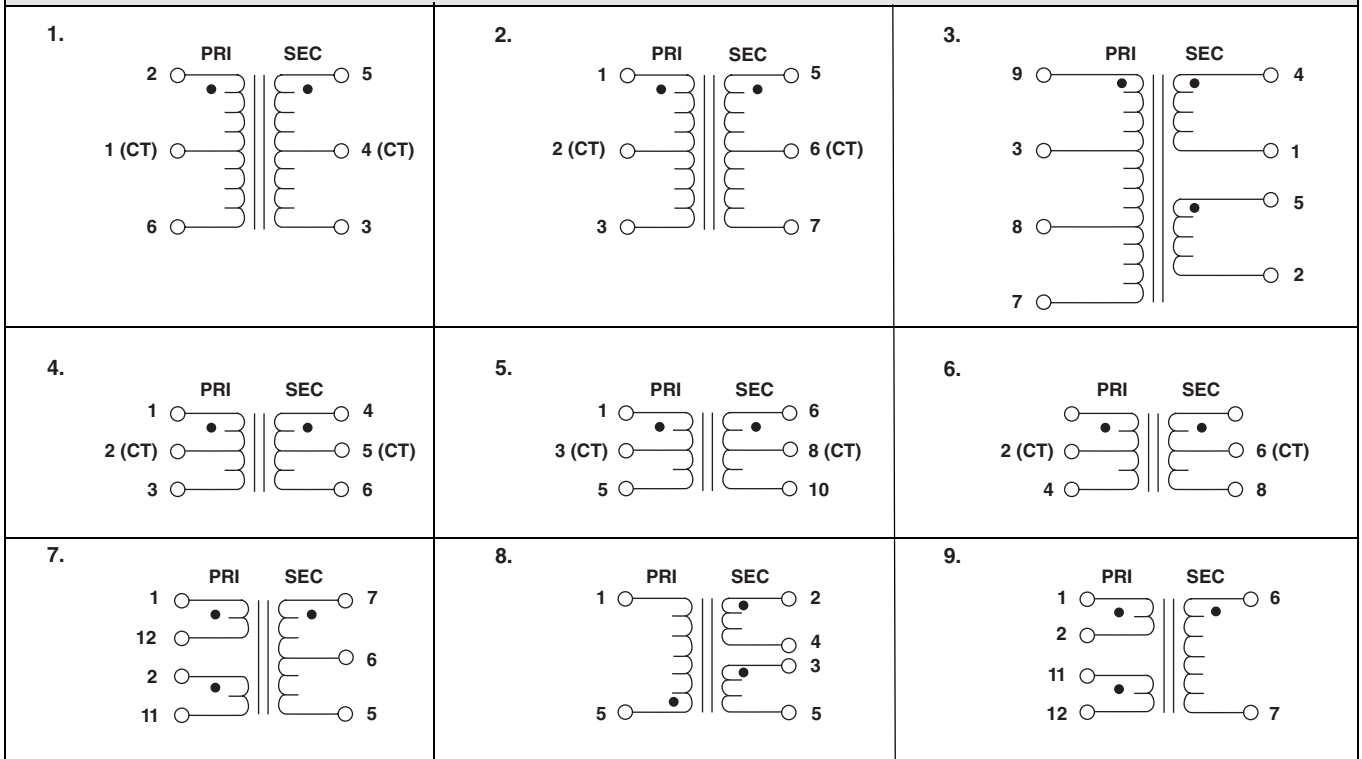

### DIMENSIONAL CONFIGURATIONS

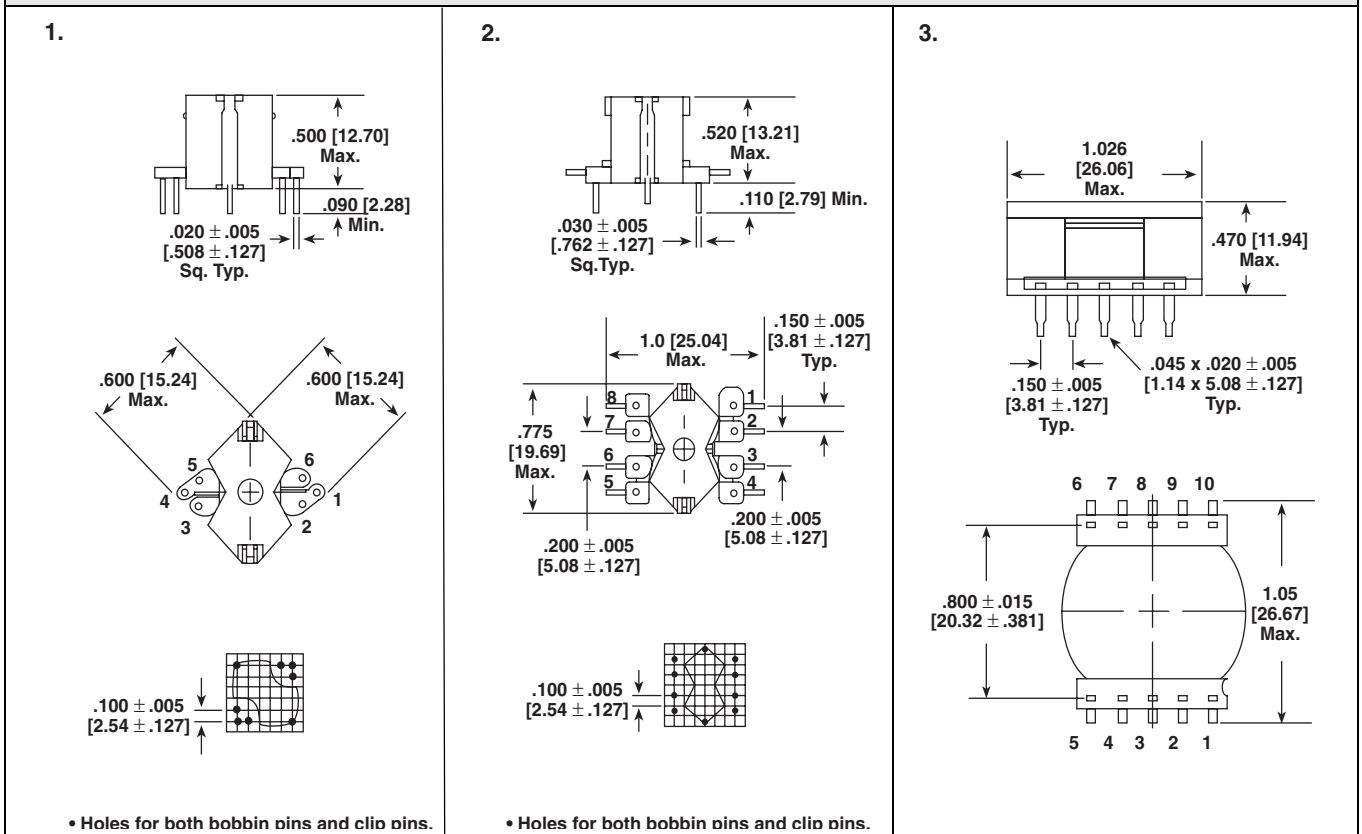

## DIMENSIONAL CONFIGURATIONS

4.

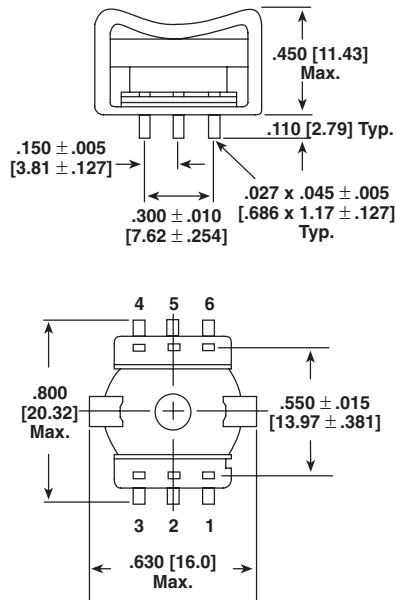

5.

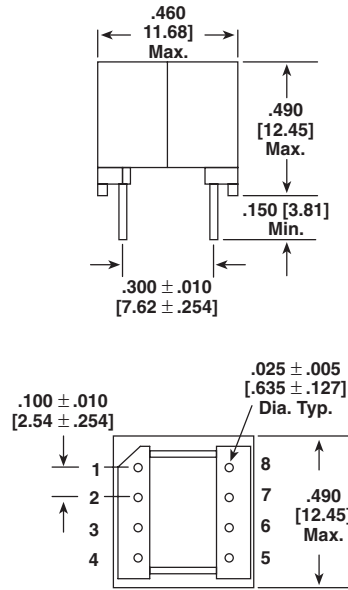

6.

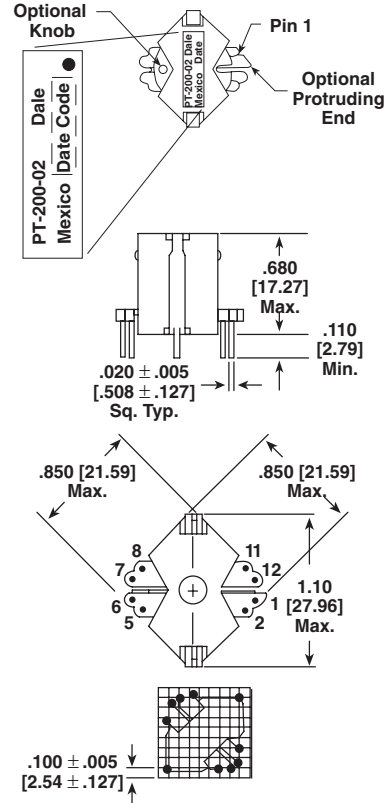

7.

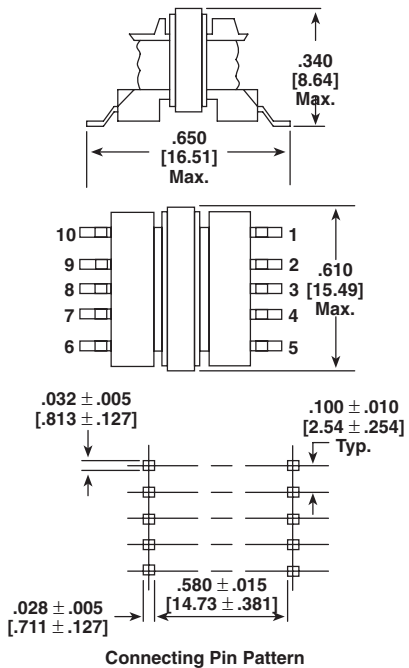

8.

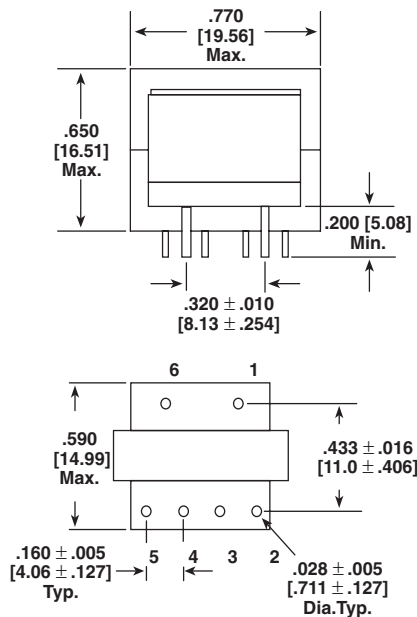

9.

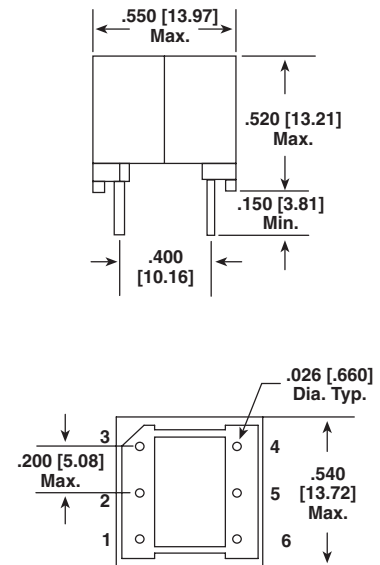



**ORDERING INFORMATION**

PT  
MODEL

100  
STYLE

01  
DASH NUMBER

EB  
PACKAGE CODE

e2  
JEDEC LEAD (Pb)-FREE  
STANDARD

**GLOBAL PART NUMBER**

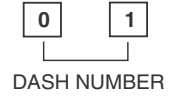
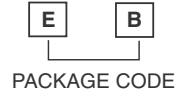
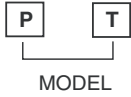



## Disclaimer

ALL PRODUCT, PRODUCT SPECIFICATIONS AND DATA ARE SUBJECT TO CHANGE WITHOUT NOTICE TO IMPROVE RELIABILITY, FUNCTION OR DESIGN OR OTHERWISE.

Vishay Intertechnology, Inc., its affiliates, agents, and employees, and all persons acting on its or their behalf (collectively, "Vishay"), disclaim any and all liability for any errors, inaccuracies or incompleteness contained in any datasheet or in any other disclosure relating to any product.

Vishay makes no warranty, representation or guarantee regarding the suitability of the products for any particular purpose or the continuing production of any product. To the maximum extent permitted by applicable law, Vishay disclaims (i) any and all liability arising out of the application or use of any product, (ii) any and all liability, including without limitation special, consequential or incidental damages, and (iii) any and all implied warranties, including warranties of fitness for particular purpose, non-infringement and merchantability.

Statements regarding the suitability of products for certain types of applications are based on Vishay's knowledge of typical requirements that are often placed on Vishay products in generic applications. Such statements are not binding statements about the suitability of products for a particular application. It is the customer's responsibility to validate that a particular product with the properties described in the product specification is suitable for use in a particular application. Parameters provided in datasheets and/or specifications may vary in different applications and performance may vary over time. All operating parameters, including typical parameters, must be validated for each customer application by the customer's technical experts. Product specifications do not expand or otherwise modify Vishay's terms and conditions of purchase, including but not limited to the warranty expressed therein.

Except as expressly indicated in writing, Vishay products are not designed for use in medical, life-saving, or life-sustaining applications or for any other application in which the failure of the Vishay product could result in personal injury or death. Customers using or selling Vishay products not expressly indicated for use in such applications do so at their own risk and agree to fully indemnify and hold Vishay and its distributors harmless from and against any and all claims, liabilities, expenses and damages arising or resulting in connection with such use or sale, including attorneys fees, even if such claim alleges that Vishay or its distributor was negligent regarding the design or manufacture of the part. Please contact authorized Vishay personnel to obtain written terms and conditions regarding products designed for such applications.

No license, express or implied, by estoppel or otherwise, to any intellectual property rights is granted by this document or by any conduct of Vishay. Product names and markings noted herein may be trademarks of their respective owners.

## Material Category Policy

**Vishay Intertechnology, Inc. hereby certifies that all its products that are identified as RoHS-Compliant fulfill the definitions and restrictions defined under Directive 2011/65/EU of The European Parliament and of the Council of June 8, 2011 on the restriction of the use of certain hazardous substances in electrical and electronic equipment (EEE) - recast, unless otherwise specified as non-compliant.**

**Please note that some Vishay documentation may still make reference to RoHS Directive 2002/95/EC. We confirm that all the products identified as being compliant to Directive 2002/95/EC conform to Directive 2011/65/EU.**