

Through Hole Transformers Converter

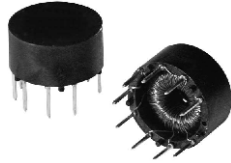

FEATURES

- Designed especially for low-power solid state circuits
- Designed for mounting on printed circuit boards
- Miniature size for minimum space
- High conversion efficiency from DC input to filtered DC output
- Compliant to RoHS directive 2002/95/EC



RoHS COMPLIANT

APPLICATIONS

Power supply for gas discharge display, battery-operated portable instruments, operational amplifier power supplies.

ELECTRICAL SPECIFICATIONS

Transformer Power Rating: 3 W
Isolation, Primary-Secondary: 500 V
 60 Hz. Operating characteristics may be varied to suit specific applications by appropriate selection of circuit components.

OPERATING TEMPERATURE RANGE:

- 20 °C to + 80 °C. Intended for use in enclosed commercial and industrial applications.

MECHANICAL SPECIFICATIONS

Coil: Secured to bottom of case with epoxy
Terminals: 0.025" [0.635 mm] square, solder plated

STANDARD ELECTRICAL SPECIFICATIONS						
MODEL	INPUT	OUTPUT	FREQ. REF. (kHz)	CIRCUIT EFF.	TEST CIRCUIT	SCHEMATIC NUMBER
TC-10-01B	3.6 V _{DC}	+ 7.2 ± 0.2 V _{DC} at 150 MW - 7.2 ± 0.2 V _{DC} at 150 MW	7.5	50 %	1	1
TC-10-02B	5 V _{DC}	200 ± 10 V _{DC} at 250 MW	11	50 %	2*	4
TC-10-03B	5 V _{DC}	200 ± 10 V _{DC} at 250 MW + 15 ± 0.4 V _{DC} at 125 MW - 15 ± 0.4 V _{DC} at 125 MW	11	60 %	2	2
TC-10-04B	5 V _{DC}	+ 15 ± 0.4 V _{DC} at 500 MW - 15 ± 0.4 V _{DC} at 500 MW	8	75 %	3	1
TC-10-05B	5 V _{DC}	+ 170 ± 5.1 V _{DC} at 850 MW + 32 ± 1.0 V _{DC} at 510 MW	11	75 %	4	5
TC-10-06B	5 V _{DC}	+ 35 ± 1.0 V _{DC} at 610 MW	11	70 %	4*	5*
TC-10-07B	7.5 V _{DC}	16.3 ± 0.4 V _{DC} at 330 MW	7	65 %	5	1
TC-10-08B	12 V _{DC}	± 15 ± 0.4 V _{DC} at 1 W	7.5	72 %	3	1
TC-10-09B	12 V _{DC}	160 ± 5 V _{DC} at 1.5 W	10	75 %	6	3
TC-10-10B	12 V _{DC}	14.2 ± 0.7 V _{DC} at 3 W	10	70 %	5	1
TC-10-11B	12 V _{DC}	+ 24 ± 0.5 V _{DC} at 2 W	10	80 %	5	1
TC-10-12B	24 V _{DC}	170 ± 5.1 V _{DC} at 850 MW 32 ± 1.0 V _{DC} at 510 MW	11	70 %	4	5

* Specifications relate to transformer when operated in applicable test circuit and at specified load power.

DIMENSIONS in inches [millimeters]

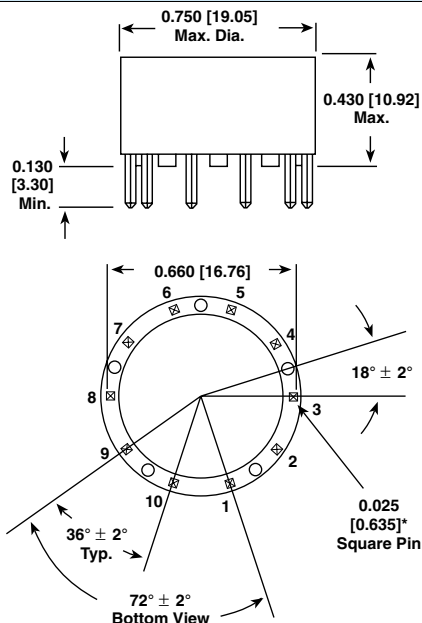

* Shows typical pin spacing. Pin #10 is omitted on all models except -05, -06, -12

SCHEMATICS

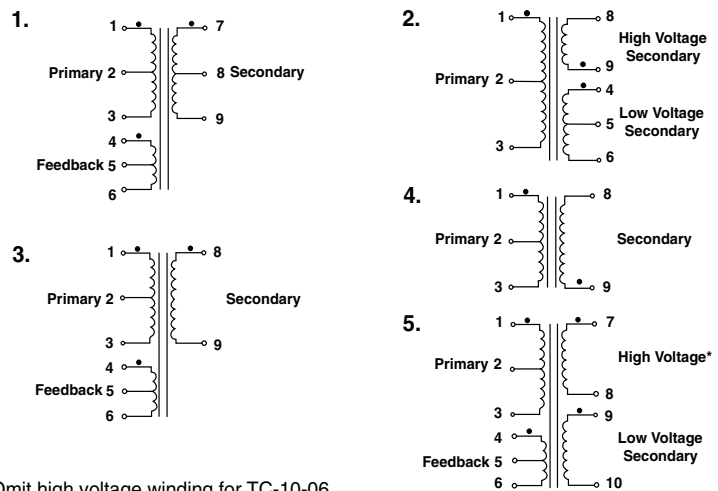

* Omit high voltage winding for TC-10-06

PART MARKING

- Model - Date code



ORDERING INFORMATION

TC-10	-01B	EB	e2
MODEL	DASH NUMBER	PACKAGE CODE	JEDEC LEAD (Pb)-FREE STANDARD

GLOBAL PART NUMBER

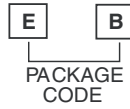
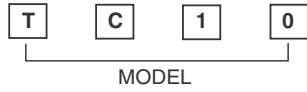



Disclaimer

ALL PRODUCT, PRODUCT SPECIFICATIONS AND DATA ARE SUBJECT TO CHANGE WITHOUT NOTICE TO IMPROVE RELIABILITY, FUNCTION OR DESIGN OR OTHERWISE.

Vishay Intertechnology, Inc., its affiliates, agents, and employees, and all persons acting on its or their behalf (collectively, "Vishay"), disclaim any and all liability for any errors, inaccuracies or incompleteness contained in any datasheet or in any other disclosure relating to any product.

Vishay makes no warranty, representation or guarantee regarding the suitability of the products for any particular purpose or the continuing production of any product. To the maximum extent permitted by applicable law, Vishay disclaims (i) any and all liability arising out of the application or use of any product, (ii) any and all liability, including without limitation special, consequential or incidental damages, and (iii) any and all implied warranties, including warranties of fitness for particular purpose, non-infringement and merchantability.

Statements regarding the suitability of products for certain types of applications are based on Vishay's knowledge of typical requirements that are often placed on Vishay products in generic applications. Such statements are not binding statements about the suitability of products for a particular application. It is the customer's responsibility to validate that a particular product with the properties described in the product specification is suitable for use in a particular application. Parameters provided in datasheets and/or specifications may vary in different applications and performance may vary over time. All operating parameters, including typical parameters, must be validated for each customer application by the customer's technical experts. Product specifications do not expand or otherwise modify Vishay's terms and conditions of purchase, including but not limited to the warranty expressed therein.

Except as expressly indicated in writing, Vishay products are not designed for use in medical, life-saving, or life-sustaining applications or for any other application in which the failure of the Vishay product could result in personal injury or death. Customers using or selling Vishay products not expressly indicated for use in such applications do so at their own risk and agree to fully indemnify and hold Vishay and its distributors harmless from and against any and all claims, liabilities, expenses and damages arising or resulting in connection with such use or sale, including attorneys fees, even if such claim alleges that Vishay or its distributor was negligent regarding the design or manufacture of the part. Please contact authorized Vishay personnel to obtain written terms and conditions regarding products designed for such applications.

No license, express or implied, by estoppel or otherwise, to any intellectual property rights is granted by this document or by any conduct of Vishay. Product names and markings noted herein may be trademarks of their respective owners.