

Half Size Clock Oscillators Enable/Disable



The XO-523 series oscillator is half size, has Tri-state enable/disable controlled function, and is with a 3.3 V power supply voltage. The metal package with pin#4 case ground acts as shielding to minimize EMI radiation.

FEATURES

- Tri-state enable/disable
- 8 pin half size
- Industry standard
- Wide frequency range
- Low cost
- Resistance weld package
- 3.3 V
- Lead (Pb)-free terminations and RoHS compliant



STANDARD ELECTRICAL SPECIFICATIONS			
PARAMETER	SYMBOL	CONDITION	XO-523
Frequency Range	F_O		1 MHz ~ 100.00 MHz
Frequency Stability*		All Condition*	± 25 ppm, ± 50 ppm, ± 100 ppm
Operating Temperature Range	T_{OPR}		0 °C ~ 70 °C (- 40 °C ~ + 85 °C option)
Storage Temperature Range	T_{STG}		- 55 °C ~ + 125 °C
Power Supply Voltage	V_{DD}		3.3 V ± 10 %
Aging (First Year)		25 °C ± 3 °C	± 5 ppm
Supply Current	I_{DD}	1 MHz to 23.999 MHz	15 mA Max
		24.000 MHz to 49.999 MHz	20 mA Max
		50.000 MHz to 69.999 MHz	30 mA Max
		70.000 MHz to 100.000 MHz	45 mA Max
Output Symmetry	Sym	At 1/2 V_{DD}	40/60 % (45/55 % Option)
Rise Time	T_r	20 % V_{DD} ~ 80 % V_{DD}	8 ns Max
Fall Time	T_f	80 % V_{DD} ~ 20 % V_{DD}	8 ns Max
Output Voltage	V_{OH}		90 % V_{DD} Min
	V_{OL}		10 % V_{DD} Max
Output Load	TTL Load		1 ~ 5 TTL
	HCMOS Load		~ 50 M : 30 pF ~ 125 M : 15 pF
Start-up Time		T_s	10 ms Max
Pin 1, tri-state function			Pin 1 = H or open... Output active at pin 5 Pin 1 = L... high impedance at pin 5

* Include: 25 °C tolerance, operating temperature range, input voltage change, aging, load change, shock and vibration.

DIMENSIONS in inches [millimeters]

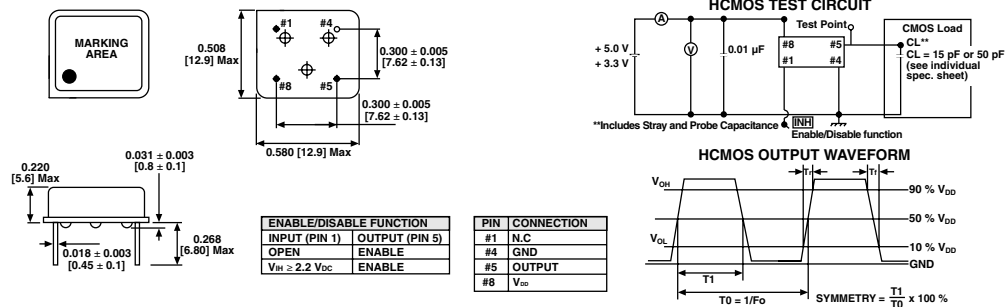

ENABLE/DISABLE FUNCTION		PIN CONNECTION	
INPUT (PIN 1)	OUTPUT (PIN 5)	#1	N.C
OPEN	ENABLE	#4	GND
$V_{IH} \geq 2.2 V_{OC}$	ENABLE	#5	OUTPUT
		#8	V_{DD}

ORDERING INFORMATION					
XO-523 MODEL	B FREQUENCY STABILITY AA = 0.0025 % (25 ppm) A = 0.005 % (50 ppm)	R OTR Blank = 0 °C to + 70 °C R = - 40 °C to + 85 °C	E ENABLE/DISABLE Blank = Pin 1 open E = Disable to Tristate	40 M FREQUENCY/MHz	e2 JEDEC LEAD (Pb)-FREE STANDARD

GLOBAL PART NUMBER												
X	O	3	2	C	T	E	L	N	A	4	0	M
MODEL				FREQUENCY STABILITY	OTR	ENABLE/ DISABLE	PACKAGE CODE	OPTIONS		FREQUENCY		



GLOBAL PART NUMBERING

MODEL NUMBER	FREQUENCY STABILITY	OPERATING TEMPERATURE (OTR)	ENABLE/DISABLE	PACKAGE CODE	OPTIONS	FREQUENCY
XO53 = XO-53 XO54 = XO-54 XO34 = XO-543 XO52 = XO-52 XO32 = XO-523 XO56 = XO-56 XOVC = XOVC-23 XO5M = XOSM-52 XO63 = XOSM-533 XO62 = XOSM-532 XO61 = XOSM-531 XO57 = XOSM-57 XO37 = XOSM-573 XO27 = XOSM-572 XO17 = XOSM-571 XO55 = XOSM-55 XO35 = XOSM-553	C = 0.01 % (100 ppm) D = 0.005 % (50 ppm) E = 0.0025 % (25 ppm)	T = 0 °C to + 70 °C R = - 40 °C to + 85 °C	F = Pin 1 Open E = Disable to Tristate	TAPE AND REEL H = RF7 BULK A = B04 (XO63, XO62, XO61) C = D06 (XO57, XO37, XO27, XO17) D = D07 (XO53, XO54, XO34, XO56, XOVC, XO55, XO35) L = D08 (XO52, XO32, XO5M)	NA = No Additional Options 60 = 45/55 Symmetry Contact factory for all other options	4M = 4 MHz 40M = 40 MHz 100M = 100 MHz 12M288 = 12.288 MHz M is used as decimal place holder in frequency

Example: XO52CTELNA40M



Disclaimer

All product specifications and data are subject to change without notice.

Vishay Intertechnology, Inc., its affiliates, agents, and employees, and all persons acting on its or their behalf (collectively, "Vishay"), disclaim any and all liability for any errors, inaccuracies or incompleteness contained herein or in any other disclosure relating to any product.

Vishay disclaims any and all liability arising out of the use or application of any product described herein or of any information provided herein to the maximum extent permitted by law. The product specifications do not expand or otherwise modify Vishay's terms and conditions of purchase, including but not limited to the warranty expressed therein, which apply to these products.

No license, express or implied, by estoppel or otherwise, to any intellectual property rights is granted by this document or by any conduct of Vishay.

The products shown herein are not designed for use in medical, life-saving, or life-sustaining applications unless otherwise expressly indicated. Customers using or selling Vishay products not expressly indicated for use in such applications do so entirely at their own risk and agree to fully indemnify Vishay for any damages arising or resulting from such use or sale. Please contact authorized Vishay personnel to obtain written terms and conditions regarding products designed for such applications.

Product names and markings noted herein may be trademarks of their respective owners.