

Printed Circuit Dip Solder Connector

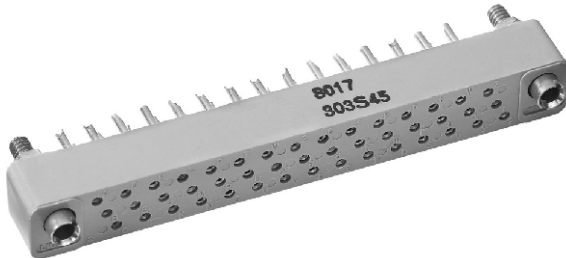

APPLICATIONS

For use in equipment requiring printed circuit connectors of the dip solder type with mating female connector.

ELECTRICAL SPECIFICATIONS

Current Rating: 3 A

Breakdown Voltage, Contact to Contact and Contact to Ground:

At sea level: 1200 V_{RMS}

At 70 000 feet: 325 V_{RMS}

FEATURES

- Guide pins polarize connectors and aid in alignment
- Mounting studs provide easy, vibration-resistant mounting to circuit board
- Male contacts molded in. Female contacts float which aids in alignment and enables connectors to withstand vibration
- Long, thin, three-row design requires a minimum of space
- Meets applicable paragraphs of MIL-C-8384

MATERIAL SPECIFICATIONS

Contact: Phosphor bronze, gold plated

Studs, Guides, Washers and Nuts: Corrosion-resistant steel, passivated

Standard Body: Glass-filled diallyl phthalate per MIL-P-19833, type GDI-30 green

PHYSICAL SPECIFICATIONS

Number of Contacts: 45

Minimum Creepage between Contacts: 0.06"

Minimum Air Space between Contacts: 0.02"

Contacts, Center to Center: 0.050"

Temperature Range: Operating and non-operating; - 62 °C to + 125 °C

DIMENSIONS in inches (millimeters)

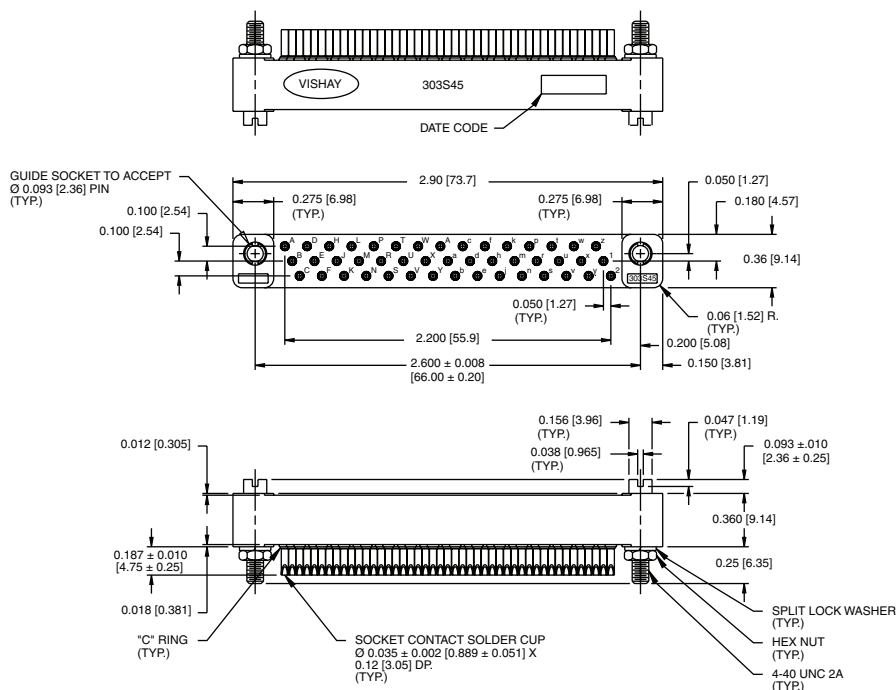

DIMENSIONS in inches (millimeters)

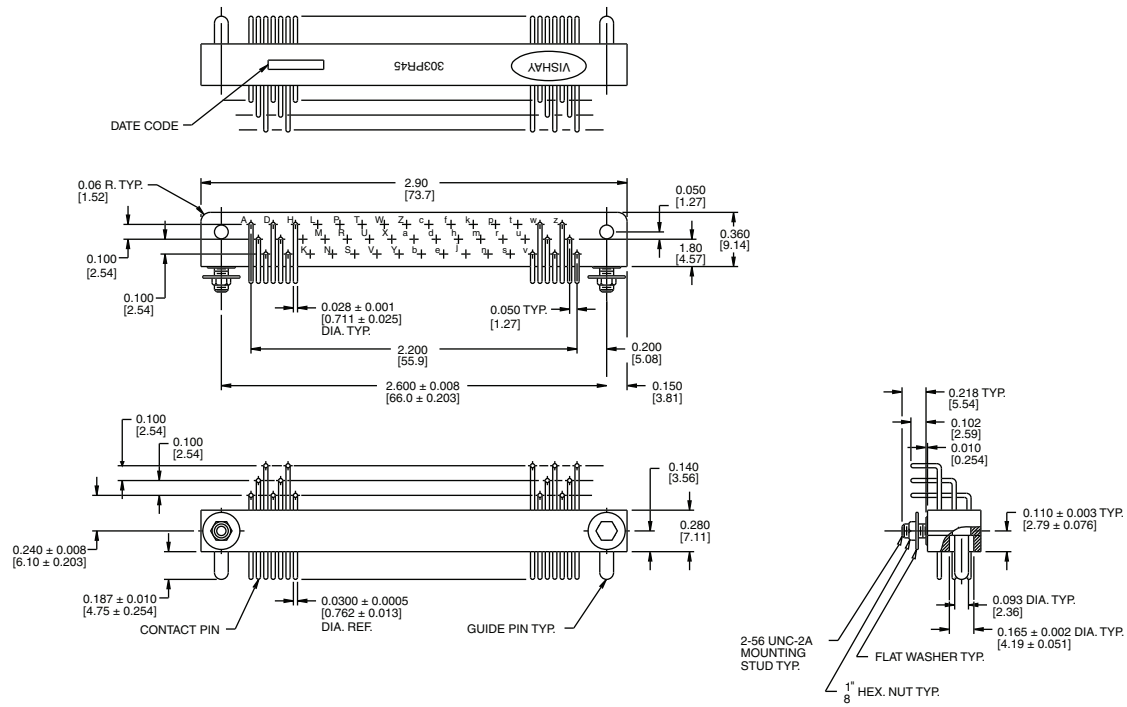

ORDERING INFORMATION

303
MODEL

PR
CONTACTS

-45
NUMBER OF CONTACTS

PR = Pin with right angle dip solder terminals
S = Socket



Disclaimer

ALL PRODUCT, PRODUCT SPECIFICATIONS AND DATA ARE SUBJECT TO CHANGE WITHOUT NOTICE TO IMPROVE RELIABILITY, FUNCTION OR DESIGN OR OTHERWISE.

Vishay Intertechnology, Inc., its affiliates, agents, and employees, and all persons acting on its or their behalf (collectively, "Vishay"), disclaim any and all liability for any errors, inaccuracies or incompleteness contained in any datasheet or in any other disclosure relating to any product.

Vishay makes no warranty, representation or guarantee regarding the suitability of the products for any particular purpose or the continuing production of any product. To the maximum extent permitted by applicable law, Vishay disclaims (i) any and all liability arising out of the application or use of any product, (ii) any and all liability, including without limitation special, consequential or incidental damages, and (iii) any and all implied warranties, including warranties of fitness for particular purpose, non-infringement and merchantability.

Statements regarding the suitability of products for certain types of applications are based on Vishay's knowledge of typical requirements that are often placed on Vishay products in generic applications. Such statements are not binding statements about the suitability of products for a particular application. It is the customer's responsibility to validate that a particular product with the properties described in the product specification is suitable for use in a particular application. Parameters provided in datasheets and/or specifications may vary in different applications and performance may vary over time. All operating parameters, including typical parameters, must be validated for each customer application by the customer's technical experts. Product specifications do not expand or otherwise modify Vishay's terms and conditions of purchase, including but not limited to the warranty expressed therein.

Except as expressly indicated in writing, Vishay products are not designed for use in medical, life-saving, or life-sustaining applications or for any other application in which the failure of the Vishay product could result in personal injury or death. Customers using or selling Vishay products not expressly indicated for use in such applications do so at their own risk and agree to fully indemnify and hold Vishay and its distributors harmless from and against any and all claims, liabilities, expenses and damages arising or resulting in connection with such use or sale, including attorneys fees, even if such claim alleges that Vishay or its distributor was negligent regarding the design or manufacture of the part. Please contact authorized Vishay personnel to obtain written terms and conditions regarding products designed for such applications.

No license, express or implied, by estoppel or otherwise, to any intellectual property rights is granted by this document or by any conduct of Vishay. Product names and markings noted herein may be trademarks of their respective owners.