

Plasma Display Modules

128 x 32 Graphics Display with Drive Electronics
TTL Level Data Interface and Integrated DC Converter



FEATURES

- TTL level video interface
- Large characters
- Highly visible for long distance viewing
- Slim profile
- > 30:1 contrast ratio
- On board DC/DC converter
- Bright and pleasant neon orange color
- Very affordable

The APD-128G032A DC plasma display offers viewing qualities designers seek such as high contrast, viewing angle of 150° minimum and long distance readability. Its bright (50 foot Lambert minimum) with characters and graphics figures presented in a pleasing neon orange color against a black background. Plasma is much more readable and eye-pleasing than liquid crystal or vacuum fluorescent displays and is filterable to red, amber or neutral density.

These plasma display panels are driven in a standard row-column refresh method much like a CRT display. The designer need only supply TTL level signals for SERIAL DATA, DOT CLOCK, COLUMN LATCH, ROW DATA, ROW CLOCK and DISPLAY ENABLE. The SERIAL DATA is entered with the DOT CLOCK up to frequencies as high as 8MHz. After a row of 128 pixels is clocked in, the COLUMN LATCH signal is toggled and the data is latched. At the time the data is latched, the display is briefly disabled using the DISPLAY ENABLE signal, then the row pointer is advanced with the ROW CLOCK signal. Once each frame the ROW DATA must be asserted to synchronize the column serial data with the beginning row. The recommended scanning frequency is approximately 70Hz, but may be as high as 200Hz. The high clock rate on the data clock allows for rapid refresh and maximum access time to the refresh ram.

ELECTRICAL SPECIFICATIONS

Voltage(s) Required: VDC: + 12 to + 24 VDC. Vcc: + 5 VDC.

Power Required: Typical = 12 watts. Maximum = 45 watts.

OPTICAL SPECIFICATIONS

Viewing Area: 12.75" [323.8mm] W x 3.15" [80.01mm] L.

Character Array: (8 x 8) 16 x 4. (6 x 8) 21 x 4.

Character Size: 0.65" [16.51mm] H x 0.45" [11.43mm] W.

Pixel Size: 0.050" [1.27mm].

Pixel Pitch: 0.100" [2.54mm].

Luminance: 50 foot lamberts.

STANDARD ELECTRICAL SPECIFICATIONS*					
DESCRIPTION	SYMBOL	MIN.	TYP.	MAX.	UNITS
DC converter input	VDC	+ 10.0	+ 24.0	+ 28.0	VDC
DC converter power @ + 12 V	Amps	Screen Clear 0.100	50% Lit 1.7	100% Lit 3.5	
Logic 1 input	Vih	2.0	—	—	VDC
Logic 0 input	Vil	—	—	0.8	VDC

*Recommended operating voltages. All maximums are absolute maximum.

ORDERING INFORMATION

<u>DESCRIPTION</u>	<u>PART NUMBER</u>
Display Module with Drivers, TTL Interface and On Board DC Converter	APD-128G032A
Power Connector	280108-13
Data Connector	280105-05

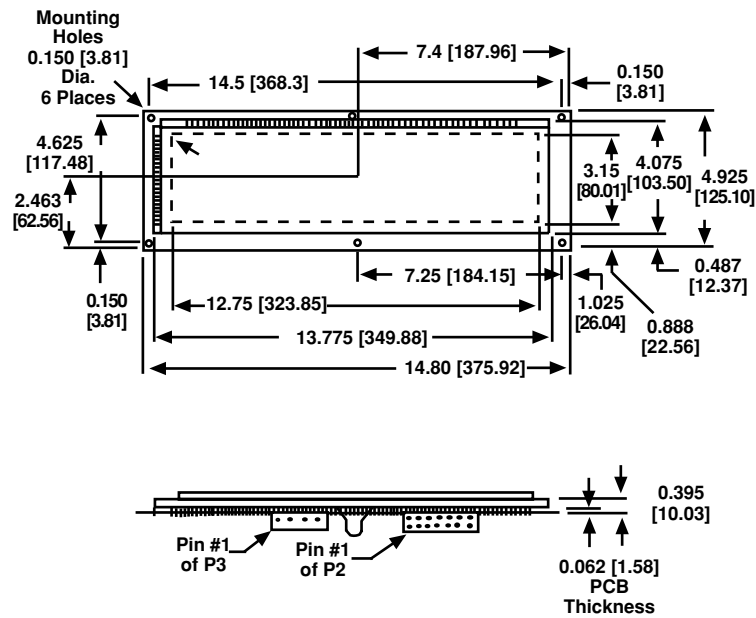
DIMENSIONS in inches [millimeters]

PIN DESCRIPTION
P3 - POWER CONNECTOR

PIN	SIGNAL	DESCRIPTION
1	VDC + 12 V	DC converter supply
2	GND	
3	GND	
4	KEY/N/C	Used to key connector

P2 - DATA CONNECTOR

AMP #103309-2 or equivalent.
Mates with AMP 746195-2, MOLEX 39-27-1146 or equivalent.

PIN	DESCRIPTION	PIN	DESCRIPTION
1	DISPLAY ENABLE	2	GROUND
3	ROW DATA	4	GROUND
5	ROW CLOCK	6	GROUND
7	COLUMN LATCH	8	GROUND
9	DOT CLOCK	10	GROUND
11	SERIAL DATA	12	GROUND
13	No connect	14	GROUND



Disclaimer

All product specifications and data are subject to change without notice.

Vishay Intertechnology, Inc., its affiliates, agents, and employees, and all persons acting on its or their behalf (collectively, "Vishay"), disclaim any and all liability for any errors, inaccuracies or incompleteness contained herein or in any other disclosure relating to any product.

Vishay disclaims any and all liability arising out of the use or application of any product described herein or of any information provided herein to the maximum extent permitted by law. The product specifications do not expand or otherwise modify Vishay's terms and conditions of purchase, including but not limited to the warranty expressed therein, which apply to these products.

No license, express or implied, by estoppel or otherwise, to any intellectual property rights is granted by this document or by any conduct of Vishay.

The products shown herein are not designed for use in medical, life-saving, or life-sustaining applications unless otherwise expressly indicated. Customers using or selling Vishay products not expressly indicated for use in such applications do so entirely at their own risk and agree to fully indemnify Vishay for any damages arising or resulting from such use or sale. Please contact authorized Vishay personnel to obtain written terms and conditions regarding products designed for such applications.

Product names and markings noted herein may be trademarks of their respective owners.