

Plasma Panel Display Modules

240 Character Display with Drive Electronics



The APD-240M026A display module displays up to 240 alphanumeric 5 x 7 dot matrix characters arranged in 6 lines of 40 characters each. The module includes drive electronics and is easily interfaced to CRT controllers.

GENERAL DESCRIPTION

The APD-240M026A consists of a DC plasma panel display and drive circuitry to accept serially entered row data and generate the required cathode and anode signals to display the desired information. The module displays information in a row scanning mode; that is, row by row beginning at the top, with each character being 5 dots wide, and with 40 characters per row, 200 bits of dot information per row is supplied to the module as serial data. When all 200 bits of row information have been loaded, the data will be displayed. This process is repeated until all 42 rows have been scanned in succession. All inputs are TTL compatible.

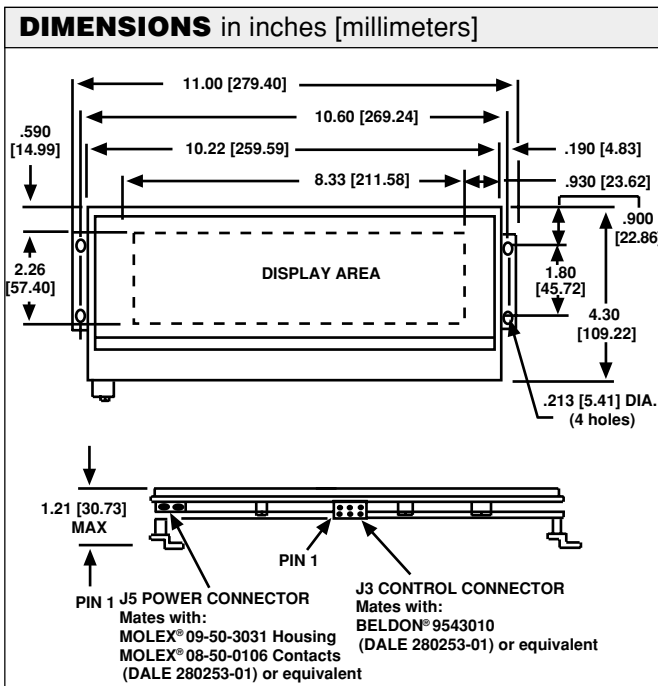

FEATURES

- 240 (6 x 40) alphanumeric characters (5 x 7 dot matrix)
- 0.14 W x .26 H character size
- High brightness (100 foot lamberts typical)
- Controller Board available with parallel and RS232 inputs
- Wide viewing angle (150°)
- Easily interfaced
- Compact size

ENVIRONMENTAL SPECIFICATIONS

Operating Temperature: 0°C to + 55°C.

Storage Temperature: - 55°C to + 85°C.

Relative Humidity: 10 - 90% non-condensing.

Mechanical Shock: 50G 1/2 Sine Wave, 11 ms duration, 5 shocks in each of 6 directions.

Vibration: 0.018" displacement amplitude from 10 to 50 Hz, 2G acceleration from 50 to 2000 Hz logarithmic sweep rate. 30 minute duration along each side of the 3 major axes.

OPTICAL SPECIFICATIONS

Viewing Area: 2.26" [57.40] W x 8.33" [211.58] L.

Number of Characters: 240.

Character Size: 0.14" [3.56] W x 0.26" [6.60] H.

Dot Size: 0.020" [0.508] diameter.

Dot Pitch, Vertical: 0.040" [1.016].

Dot Pitch, Horizontal: 0.030" [0.762].

Character Spacing: 2 blank columns of dots between successive characters.

Brightness: 100 foot lamberts.

Color: Neon orange.

Viewing Angle: 150° cone.

STANDARD ELECTRICAL SPECIFICATIONS

	MIN.	TYP.	MAX.	UNITS
Logic Supply 1 Voltage	4.75	5.0	5.25	V
Logic Supply 2 Voltage	11.40	12.0	12.60	V
Logic Supply 1 Current	—	50.0	60.0	mA
Logic Supply 2 Current	—	60.0	75.0	mA
Panel Supply 1 Voltage	60.0	65.0	70.0	V
Panel Supply 2 Voltage	- 110.0	- 115.0	- 120.0	V
Panel Supply 1 Current	—	60.0	128.0	mA
Panel Supply 2 Current	—	80.0	135.0	mA



INTERFACE SIGNAL DESCRIPTION

SERIAL DATA - The 200 bits of data that represent one row of character data is serially entered on this input. The information is entered at the 200th dot position (right side of display) and is advanced one column with each Data Shift pulse.

DATA SHIFT - A negative going edge on this input enters the row data bit present at the Serial Data input. This input requires 200 pulses to enter the 200 bits of row data.

SCAN CLOCK - Much like horizontal sync on a CRT, this signal is used to advanced the the row pointer vertically down the display, one row at a time. This input must be continually pulsed whenever the display is on to prevent damage to the panel.

SCAN SYNC - This pulse is applied after each complete scan to begin a new scan at the top row of the panel, similar to vertical sync on a CRT.

PIN DESCRIPTION

CONNECTOR	PIN	SIGNAL
J3	1	DATA SHIFT
	2	GROUND
	3	N/C
	4	+ 12 VDC
	5	SCAN SYNC
	6	SCAN CLOCK
	7	+ 5 VDC
	8	SCAN MONITOR
	9	GROUND
	10	SERIAL DATA
J5	A	- 115 VDC
	B	GROUND
	C	+ 65 VDC

SYSTEM BLOCK DIAGRAM

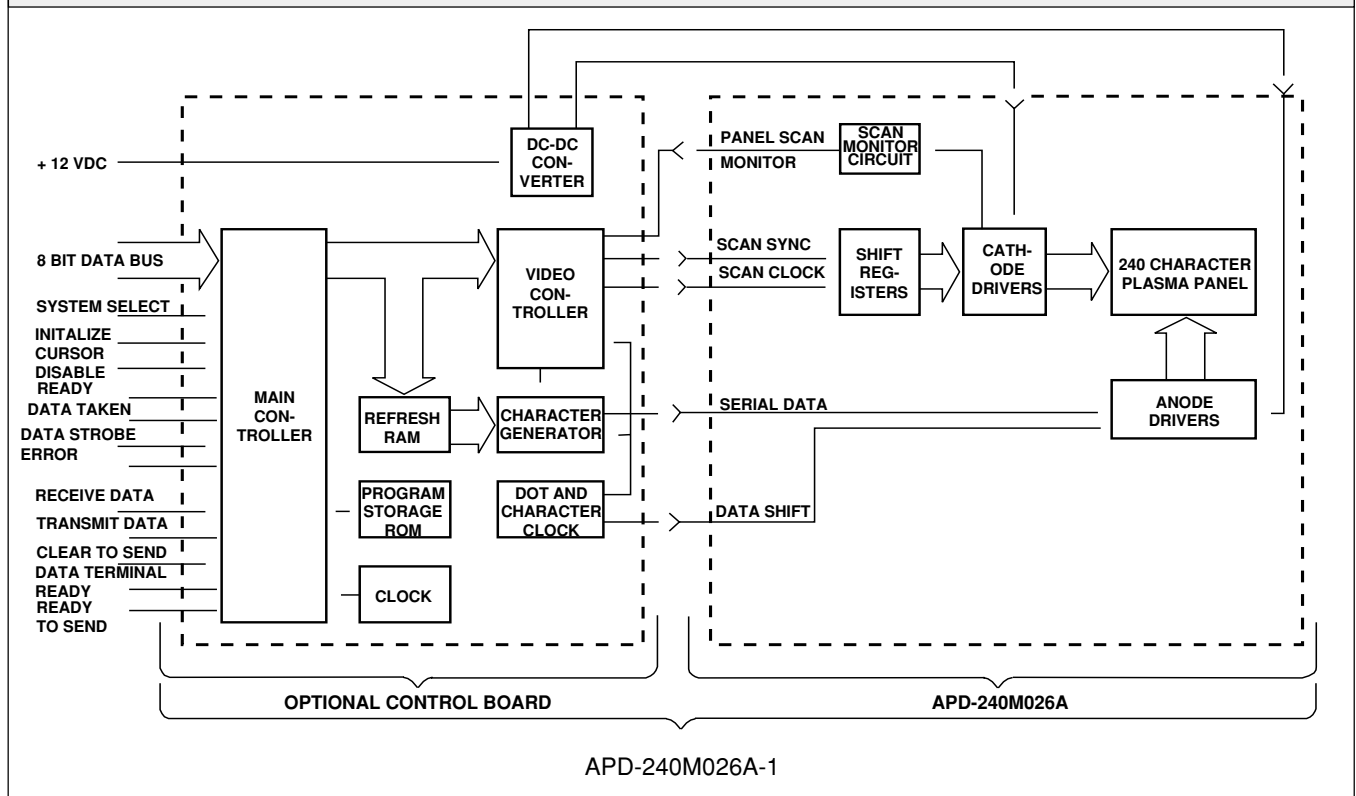

ORDERING INFORMATION

DESCRIPTION	PART NO.
Display and Drive Electronics	APD-240M026A
Display and Drive Electronics plus Controller Board (includes DC-DC high voltage converter)	APD-240M026A-1
DC-DC High Voltage Converter	PDS-400
Data Connector Kit	280253-01
Power Connector Kit	280108-01
Non-Glare Filter (amber circularly polarized) - other filters available - contact factory	280109-03



Disclaimer

All product specifications and data are subject to change without notice.

Vishay Intertechnology, Inc., its affiliates, agents, and employees, and all persons acting on its or their behalf (collectively, "Vishay"), disclaim any and all liability for any errors, inaccuracies or incompleteness contained herein or in any other disclosure relating to any product.

Vishay disclaims any and all liability arising out of the use or application of any product described herein or of any information provided herein to the maximum extent permitted by law. The product specifications do not expand or otherwise modify Vishay's terms and conditions of purchase, including but not limited to the warranty expressed therein, which apply to these products.

No license, express or implied, by estoppel or otherwise, to any intellectual property rights is granted by this document or by any conduct of Vishay.

The products shown herein are not designed for use in medical, life-saving, or life-sustaining applications unless otherwise expressly indicated. Customers using or selling Vishay products not expressly indicated for use in such applications do so entirely at their own risk and agree to fully indemnify Vishay for any damages arising or resulting from such use or sale. Please contact authorized Vishay personnel to obtain written terms and conditions regarding products designed for such applications.

Product names and markings noted herein may be trademarks of their respective owners.