

## COTS Guide for Tantalum Capacitors

### INTRODUCTION

Tantalum electrolytic capacitors are the preferred choice in applications where volumetric efficiency, stable electrical parameters, high reliability, and long service life are primary considerations. The stability and resistance to elevated temperatures of the tantalum/tantalum oxide/manganese dioxide system make solid tantalum capacitors an appropriate choice for today's surface mount assembly technology.

Vishay Sprague has been a pioneer and leader in this field, producing a large variety of tantalum capacitor types for consumer, industrial, automotive, military, and aerospace electronic applications.

Tantalum is not found in its pure state. Rather, it is commonly found in a number of oxide minerals, often in combination with Columbium ore. This combination is known as "tantalite" when its contents are more than one-half tantalum. Important sources of tantalite include Australia, Brazil, Canada, China, and several African countries. Synthetic tantalite concentrates produced from tin slags in Thailand, Malaysia, and Brazil are also a significant raw material for tantalum production.

Electronic applications, and particularly capacitors, consume the largest share of world tantalum production. Other important applications for tantalum include cutting tools (tantalum carbide), high temperature super alloys, chemical processing equipment, medical implants, and military ordnance.

Vishay Sprague is a major user of tantalum materials in the form of powder and wire for capacitor elements and rod and sheet for high temperature vacuum processing.

### THE BASICS OF TANTALUM CAPACITORS

Most metals form crystalline oxides which are non-protecting, such as rust on iron or black oxide on copper. A few metals form dense, stable, tightly adhering, electrically insulating oxides. These are the so-called "valve" metals and include titanium, zirconium, niobium, tantalum, hafnium, and aluminum. Only a few of these permit the accurate control of oxide thickness by electrochemical means. Of these, the most valuable for the electronics industry are aluminum and tantalum.

Capacitors are basic to all kinds of electrical equipment, from radios and television sets to missile controls and automobile ignitions. Their function is to store an electrical charge for later use.

Capacitors consist of two conducting surfaces, usually metal plates, whose function is to conduct electricity. They are separated by an insulating material or dielectric. The dielectric used in all tantalum electrolytic capacitors is tantalum pentoxide.

Tantalum pentoxide compound possesses high-dielectric strength and a high-dielectric constant. As capacitors are being manufactured, a film of tantalum pentoxide is applied to their electrodes by means of an electrolytic process. The film is applied in various thicknesses and at various voltages and although transparent to begin with, it takes on different colors as light refracts through it. This coloring occurs on the tantalum electrodes of all types of tantalum capacitors.

Rating for rating, tantalum capacitors tend to have as much as three times better capacitance/volume efficiency than aluminum electrolytic capacitors. An approximation of the capacitance/volume efficiency of other types of capacitors may be inferred from the following table, which shows the dielectric constant ranges of the various materials used in each type. Note that tantalum pentoxide has a dielectric constant of 26, some three times greater than that of aluminum oxide. This, in addition to the fact that extremely thin films can be deposited during the electrolytic process mentioned earlier, makes the tantalum capacitor extremely efficient with respect to the number of microfarads available per unit volume. The capacitance of any capacitor is determined by the surface area of the two conducting plates, the distance between the plates, and the dielectric constant of the insulating material between the plates.

#### COMPARISON OF CAPACITOR DIELECTRIC CONSTANTS

DIELECTRIC	$\epsilon$ DIELECTRIC CONSTANT
Air or Vacuum	1.0
Paper	2.0 to 6.0
Plastic	2.1 to 6.0
Mineral Oil	2.2 to 2.3
Silicone Oil	2.7 to 2.8
Quartz	3.8 to 4.4
Glass	4.8 to 8.0
Porcelain	5.1 to 5.9
Mica	5.4 to 8.7
Aluminum Oxide	8.4
<b>Tantalum Pentoxide</b>	<b>26</b>
Ceramic	12 to 400K

In the tantalum electrolytic capacitor, the distance between the plates is very small since it is only the thickness of the tantalum pentoxide film. As the dielectric constant of the tantalum pentoxide is high, the capacitance of a tantalum capacitor is high if the area of the plates is large:

$$C = \frac{\epsilon A}{t}$$

where

C = capacitance

$\epsilon$  = dielectric constant

A = surface area of the dielectric

t = thickness of the dielectric

Tantalum capacitors contain either liquid or solid electrolytes. In solid electrolyte capacitors, a dry material (manganese dioxide) forms the cathode plate. A tantalum lead is embedded in or welded to the pellet, which is in turn connected to a termination or lead wire. The drawings show the construction details of the surface mount types of tantalum capacitors shown in this catalog.

**SOLID ELECTROLYTE TANTALUM CAPACITORS**

Solid electrolyte capacitors contain manganese dioxide, which is formed on the tantalum pentoxide dielectric layer by impregnating the pellet with a solution of manganous nitrate. The pellet is then heated in an oven, and the manganous nitrate is converted to manganese dioxide.

The pellet is next coated with graphite, followed by a layer of metallic silver, which provides a conductive surface between the pellet and the external termination.

The pellet, with lead wire and header attached, is inserted into the can where the pellet is held in place by solder. The can cover is also soldered into place.

After assembly, the capacitors are tested and inspected to assure long life and reliability. It offers excellent reliability and high stability for consumer and commercial electronics with the added feature of low cost.





Surface mount designs of "Solid Tantalum" capacitors use lead frames or lead frameless designs as shown in the accompanying drawings.



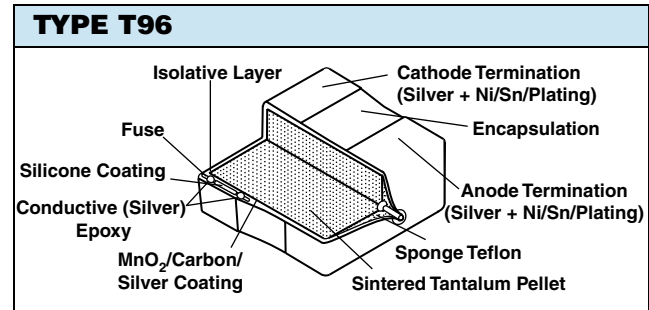
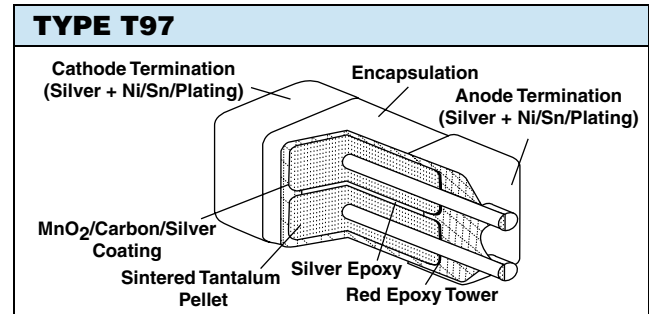
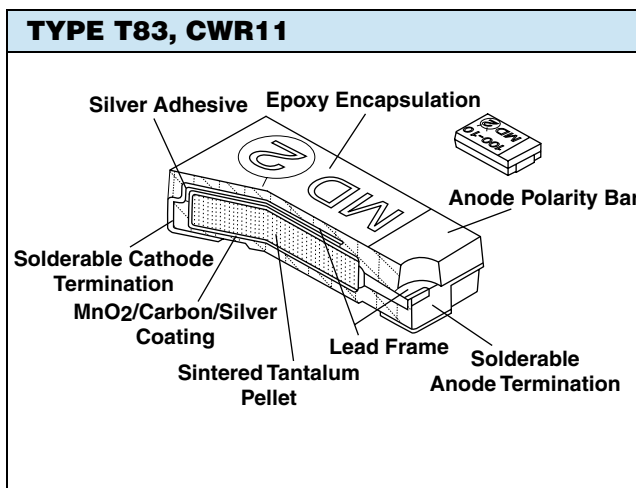
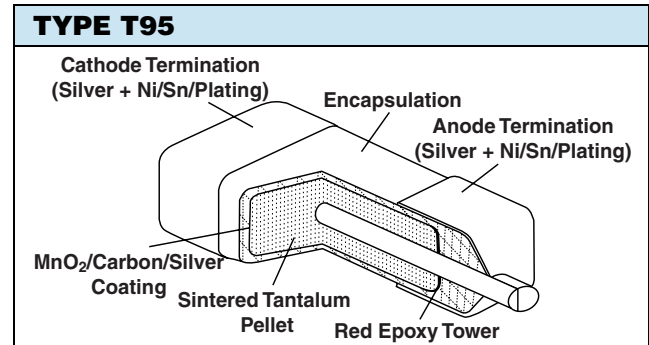
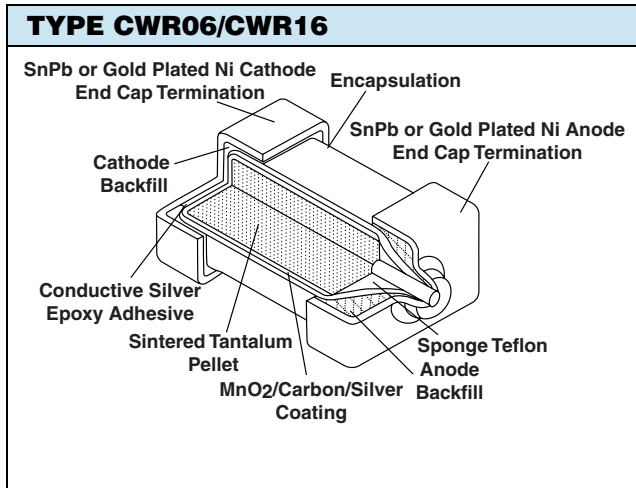

**TANTALUM CAPACITORS FOR ALL DESIGN CONSIDERATIONS**

Solid electrolyte designs are the least expensive for a given rating and are used in many applications where their very small size for a given unit of capacitance is of importance. They will typically withstand up to about 10 % of the rated DC working voltage in a reverse direction. Also important are their good low temperature performance characteristics and freedom from corrosive electrolytes.

Vishay Sprague patented the original solid electrolyte capacitors and was the first to market them in 1956. Vishay Sprague has the broadest line of tantalum capacitors and has continued its position of leadership in this field. Data sheets covering the various types and styles of Vishay Sprague capacitors for consumer and entertainment electronics, industry, and military applications are available where detailed performance characteristics must be specified.



SOLID TANTALUM CAPACITORS				
SERIES	T83	T95	T96	CWR11
PRODUCT IMAGE				
TYPE	Surface Mount TANTAMOUNT® Chip, Hi-Rel COTS, Molded Case	Surface Mount TANTAMOUNT® Chip, Hi-Rel COTS, Conformal Coated	Surface Mount TANTAMOUNT® Chip, Hi-Rel COTS, Conformal Coated	TANTAMOUNT® Solid Electrolyte Chip, Molded
FEATURES	Hi-Rel COTS, lead (Pb)-free, RoHS compliant	Hi-Rel, Maximum CV, lead (Pb)-free, RoHS compliant	Hi-Rel, Built-In Fuse, Maximum CV, lead (Pb)-free, RoHS compliant	MIL-C-55365/8 Qualified
TEMPERATURE RANGE (°C)	- 55 °C to + 125 °C	- 55 °C to + 125 °C	- 55 °C to + 125 °C	- 55 °C to + 125 °C
CAPACITANCE RANGE (µF)	0.1 µF to 330 µF	0.10 µF to 680 µF	0.10 µF to 680 µF	0.10 µF to 100 µF
VOLTAGE RANGE (V)	4 ~ 50	4 ~ 50	4 ~ 50	4 ~ 50
CAPACITANCE TOLERANCE (%)	± 20, ± 10	± 20, ± 10	± 20, ± 10	± 20, ± 10
LEAKAGE CURRENT (µA)	0.01 CV or 0.5 µA max.	0.01 CV or 0.5 µA max.	0.01 CV or 0.5 µA max.	0.01 CV or 0.5 µA max.
DISSIPATION FACTOR	4 ~ 8 max.	4 ~ 20 max.	6 ~ 14 max.	4 ~ 12 max.
CASE CODES	A, B, C, D, E	B, C, D, R, S, V, X, Y, Z	R	A, B, C, D

SOLID TANTALUM CAPACITORS				
SERIES	CWR06	CWR16	T97	T98
PRODUCT IMAGE				
TYPE	Surface Mount MIDGET® Solid Electrolyte Chip, Conformal Coated	Surface Mount MIDGET® Solid Electrolyte Chip, Conformal Coated	Surface Mount TANTAMOUNT® Chip, Hi-Rel COTS, Conformal Coated	Surface Mount TANTAMOUNT® Chip, Hi-Rel COTS, Conformal Coated
FEATURES	MIL-C-55365/4 Qualified, RoHS compliant	MIL-C-55365/13 Qualified, RoHS compliant	Hi-Rel, Maximum CV, Ultra-Low ESR lead (Pb)-free, RoHS compliant	Hi-Rel, Maximum CV, Ultra-Low ESR lead (Pb)-free, RoHS compliant, Built-In Fuse after ESR
TEMPERATURE RANGE (°C)	- 55 °C to + 125 °C	- 55 °C to + 125 °C	- 55 °C to + 125 °C	- 55 °C to + 125 °C
CAPACITANCE RANGE (µF)	0.10 µF to 100 µF	0.33 µF to 330 µF	22 µF to 1500 µF	15 µF to 1500 µF
VOLTAGE RANGE (V)	4 ~ 50	4 ~ 35	4 ~ 50	4 ~ 63
CAPACITANCE TOLERANCE (%)	± 20, ± 10	± 20, ± 10	± 20, ± 10	± 20, ± 10
LEAKAGE CURRENT (µA)	0.01 CV or 0.5 µA max.	0.01 CV or 0.5 µA max.	0.01 CV or 0.5 µA max.	0.01 CV or 0.5 µA max.
DISSIPATION FACTOR	6 ~ 12 max.	6 ~ 12 max.	6 ~ 8 max.	6 ~ 8 max.
CASE CODES	A, B, C, D, E, F, G, H	A, B, C, D, E, F, G, H	E, F, R, V	E, F, R, V, Z

\* Preliminary, contact Product Marketing for availability.

**TAPE AND REEL PACKAGING** in inches [millimeters]

Note: Metric dimensions will govern. Dimensions in inches are rounded and for reference only.

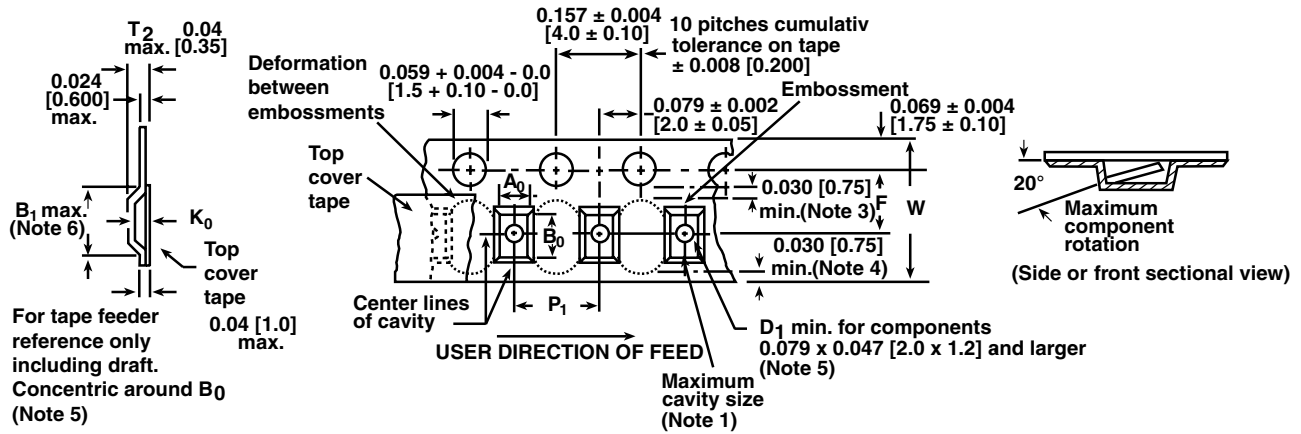

For tape feeder reference only including draft. Concentric around B<sub>0</sub> (Note 5)

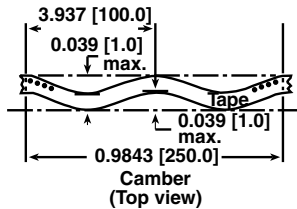
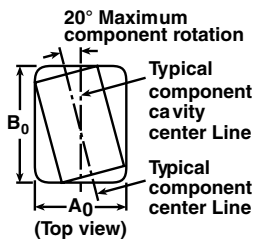
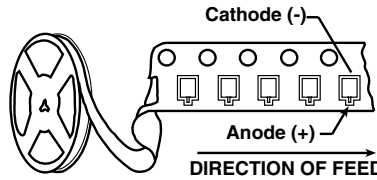

Allowable camber to be 0.039/3.937 [1/100] Non-cumulative over 9.843 [250.0]

**Tape and Reel Specifications:** All case sizes are available on plastic embossed tape per EIA-481-1. Tape reeling per IEC 286-3 is also available. Standard reel diameter is 7" [178 mm]. 13" [330 mm] reels are available and recommended as the most cost effective packaging method.

The most efficient packaging quantities are full reel increments on a given reel diameter. The quantities shown allow for the sealed empty pockets required to be in conformance with EIA-481-1. Reel size and packaging orientation must be specified in the Vishay Sprague part number.

**CARRIER TAPE DIMENSIONS** in inches [millimeters]

**T83 - CWR11**

CASE CODE	TAPE SIZE	B <sub>1</sub> (MAX.)	D <sub>1</sub> (MIN.)	F	T <sub>2</sub>	P	W
A, B	8 mm	0.165 [4.2]	0.039 [1.0]	0.138 ± 0.002 [3.5 ± 0.05]	0.094 [2.4]	0.157 ± 0.004 [4.0 ± 1.0]	0.315 ± 0.012 [8.0 ± 0.3]
C, D, E	12 mm	0.323 [8.2]	0.059 [1.5]	0.217 ± 0.002 [5.5 ± 0.05]	0.177 [4.5]	0.315 ± 0.004 [8.0 ± 1.0]	0.472 ± 0.012 [12.0 ± 0.30]

**T95 - T96**

CASE CODE	TAPE SIZE	B <sub>1</sub> (MAX.)	D <sub>1</sub> (MIN.)	F	P <sub>1</sub>	T <sub>2</sub> (MAX.)	W
A, S	8 mm	0.179 [4.55]	0.039 [1.0]	0.138 ± 0.002 [3.5 ± 0.05]	0.157 ± 0.004 [4.0 ± 0.10]	0.098 [2.5]	0.315 ± 0.012 [8.0 ± 0.3]
B, V, X, Y, Z	12 mm	0.323 [8.2]	0.059 [1.5]	0.217 ± 0.002 [5.5 ± 0.05]	0.157 ± 0.004 [4.0 ± 0.10]	0.256 [6.5]	0.472 ± 0.012 [12.0 ± 0.30]
C, D, R	12 mm Double Pitch	0.323 [8.2]	0.059 [1.5]	0.217 ± 0.002 [5.5 ± 0.05]	0.315 ± 0.004 [8.0 ± 0.10]	0.256 [6.5]	0.472 ± 0.012 [12.0 ± 0.30]

**CWR06/CWR16**

CASE CODE	TAPE SIZE	B <sub>1</sub> (MAX.)	D <sub>1</sub> (MAX.)	F	P <sub>1</sub>	T <sub>2</sub> (MAX.)	W
A	8 mm	0.179 [4.55]	0.039 [1.0]	0.138 ± 0.002 [3.5 ± 0.05]	0.157 ± 0.004 [2.0 ± 0.05]	0.098 [2.5]	0.315 ± 0.012 - 0.004 [8.0 ± 0.3 - 0.1]
B, C, D, E, F	12 mm	0.323 [8.2]	0.059 [1.5]	0.217 ± 0.002 [5.5 ± 0.05]	0.157 ± 0.004 [2.0 ± 0.05]	0.256 [6.5]	0.472 ± 0.012 [12.0 ± 0.30]
G, H	16 mm	0.476 [12.1]	0.059 [1.5]	0.295 ± 0.004 [7.5 ± 0.1]	0.315 ± 0.004 [8.0 ± 0.10]	0.315 [8.0]	0.642 Max. [16.3] Max.



<b>CARRIER TAPE DIMENSIONS</b> in inches [millimeters]							
<b>T97 - T98</b>							
V	12 mm	0.388 [9.79]	0.059 [1.5]	0.218 ± 0.02 [5.5 ± 0.5]	0.317 ± 0.004 [8.0 ± 0.10]	0.089 [2.25]	0.479 + 0.012 - 0.004 [12.0 + 0.3 - 0.1]
E	16 mm	0.388 [9.79]	0.059 [1.5]	0.297 ± 0.02 [7.5 ± 0.5]	0.317 ± 0.004 [8.0 ± 0.10]	0.174 [4.40]	0.635 + 0.012 - 0.004 [16.0 + 0.3 - 0.1]
F, R	16 mm	0.388 [9.79]	0.059 [1.5]	0.297 ± 0.02 [7.5 ± 0.5]	0.476 ± 0.004 [12.0 ± 0.1]	0.163 [4.10]	0.635 + 0.012 - 0.004 [16.0 + 0.3 - 0.1]
Z	16 mm	0.388 [9.79]	0.059 [1.5]	0.297 ± 0.02 [7.5 ± 0.5]	0.476 ± 0.004 [12.0 ± 0.1]	0.239 [6.06]	0.635 + 0.012 - 0.004 [16.0 + 0.3 - 0.1]

\* Preliminary, contact Product Marketing for availability

<b>RECOMMENDED VOLTAGE DERATING GUIDELINES</b>	
<b>STANDARD CONDITIONS: FOR EXAMPLE: OUTPUT FILTERS</b>	
<b>Capacitor Voltage Rating</b>	<b>Operating Voltage</b>
4.0	2.5
6.3	3.6
10	6.0
16	10
20	12
25	15
35	24
50	28
63	38
<b>SEVERE CONDITIONS: FOR EXAMPLE: INPUT FILTERS</b>	
<b>Capacitor Voltage Rating</b>	<b>Operating Voltage</b>
4.0	2.5
6.3	3.3
10	5.0
16	8.0
20	10
25	12
35	15
50	24
63	32

<b>STANDARD PACKAGING QUANTITY</b>				
SERIES	CASE CODE	QUANTITY (PCS/REEL)		
		7" REEL	13" REEL	HALF REEL
T83 CWR11	A	2000	9000	
	B	2000	8000	
	C	500	3000	
	D	500	2500	
	E	400	1500	
T95 T96	A	2000	9000	1000
	B	2000	8000	1000
	C	500	3000	250
	D	500	2500	250
	R	600	N/A	300
	S	2500	10 000	1250
	V	2500	10 000	1250
	X	2000	10 000	1000
	Y	1500	7500	750
Z	1500	5000	750	
CWR06/CWR16	A, B, C, D, E	2500	10 000	1250
	F	1000	4000	500
	G, H	600	2500	300
T97 T98	E	500	N/A	250
	V	1000	N/A	500
	F, R	300	N/A	150
	H	200	N/A	100
	Z	250	N/A	125

POWER DISSIPATION		
CASE CODE		MAXIMUM PERMISSIBLE
CWR06/CWR16	A	0.06
	B, C	0.075
	D, E	0.085
	F	0.11
	G	0.12
	H	0.15
T83 CWR11	A	0.075
	B	0.085
	C	0.110
	D	0.150
	E	0.165
T95 T96	A	0.075
	B	0.085
	C	0.110
	D	0.150
	R	0.250
	S	0.080
	V	0.095
	X	0.110
	Y	0.120
T97 T98	E	0.215
	F, R	0.250
	Z	0.265
	V	0.140

**RECOMMENDED REFLOW PROFILES**

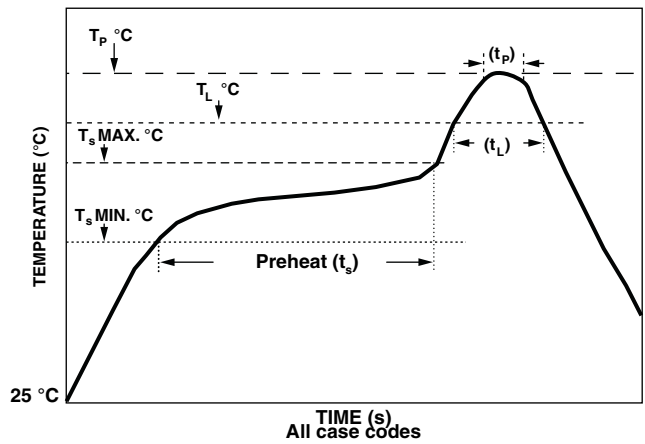

TYPE	CASE CODE	T <sub>p</sub> Pb FREE	T <sub>p</sub> Sn/Pb	t <sub>p</sub>	T <sub>L</sub> Pb FREE	T <sub>L</sub> Sn/Pb	T <sub>s</sub> MIN. Pb FREE	T <sub>s</sub> MIN. Sn/Pb	T <sub>s</sub> MAX. Pb FREE	T <sub>s</sub> MAX. Sn/Pb	t <sub>s</sub> Pb FREE	t <sub>s</sub> Sn/Pb	t <sub>L</sub>
T83 CWR11	A, B, C, D, E	260 °C	240 °C	10	217 °C	183 °C	150 °C	100 °C	200 °C	150 °C	60 to 150	60 to 90	60
T95	B, C, S, V, X, Y	260 °C	225 °C	10	217 °C	183 °C	150 °C	100 °C	200 °C	150 °C	60 to 150	60 to 150	60
	D, R, Z	245 °C											
T96	R	245 °C	225 °C	10	217 °C	183 °C	150 °C	100 °C	200 °C	150 °C	60 to	60 to	60
CWR06/ CWR16	A, B, C, D, E, F	N/A	240 °C	10	217 °C	183 °C	150 °C	100 °C	200 °C	150 °C	60 to 150	60 to 150	60
CWR06/ CWR16	G, H	N/A	225 °C	10	217 °C	183 °C	150 °C	100 °C	200 °C	150 °C	60 to 150	60 to 150	60
T97, T98	E, F, R, V, Z	245 °C	225 °C	10	217 °C	183 °C	150 °C	100 °C	200 °C	150 °C	60 to	60 to	60

**PAD DIMENSIONS** in inches [millimeters]

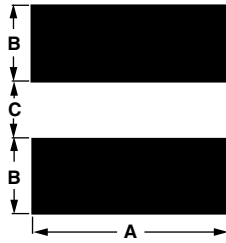

CASE CODE	WIDTH (A)	PAD METALLIZATION (B)	SEPARATION (C)
<b>T95</b>			
B	0.120 [3.0]	0.059 [1.5]	0.059 [1.5]
C	0.136 [3.5]	0.090 [2.3]	0.120 [3.1]
D	0.180 [4.6]	0.090 [2.3]	0.136 [3.47]
R	0.248 [6.3]	0.090 [2.3]	0.140 [3.6]
S	0.080 [2.03]	0.040 [1.02]	0.040 [1.02]
V	0.114 [2.9]	0.040 [1.02]	0.040 [1.02]
X, Y, Z	0.114 [2.9]	0.065 [1.65]	0.122 [3.1]
<b>T96</b>			
R	0.248 [6.3]	0.090 [2.3]	0.140 [3.6]
<b>CWR06/CWR16</b>			
A	0.065 [1.6]	0.50 [1.3]	0.040 [1.0]
B	0.065 [1.6]	0.70 [1.8]	0.055 [1.4]
C	0.065 [1.6]	0.70 [1.8]	0.120 [0.3]
D	0.115 [2.9]	0.70 [1.8]	0.070 [1.8]
E	0.115 [2.9]	0.70 [1.8]	0.120 [3.0]
F	0.150 [3.8]	0.70 [1.8]	0.140 [3.6]
G	0.125 [3.2]	0.70 [1.8]	0.170 [4.3]
H	0.165 [4.2]	0.90 [2.3]	0.170 [4.3]
<b>T97 - T98</b>			
E, V	0.196 [4.9]	0.090 [2.3]	0.145 [3.7]
F, R, Z	0.260 [6.6]	0.090 [2.3]	0.140 [3.6]

**PAD DIMENSIONS** in inches [millimeters]

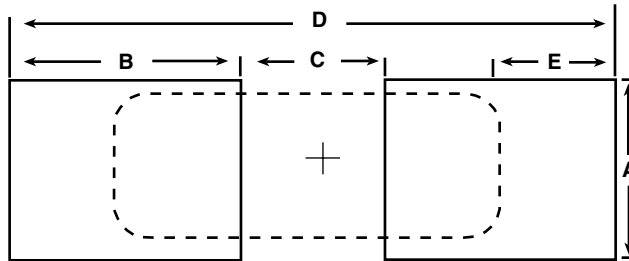

CASE CODE	A (MIN.)	B (NOM.)	C (NOM.)	D (NOM.)
<b>T83 - CWR11</b>				
A	0.071 [1.80]	0.085 [2.15]	0.053 [1.35]	0.222 [5.65]
B	0.110 [2.80]	0.085 [2.15]	0.065 [1.65]	0.234 [5.95]
C	0.110 [2.80]	0.106 [2.70]	0.124 [3.15]	0.337 [8.55]
D	0.118 [3.00]	0.106 [2.70]	0.175 [4.45]	0.388 [9.85]
E	0.118 [3.00]	0.106 [2.70]	0.175 [4.45]	0.388 [9.85]

\* Preliminary, contact Product Marketing for availability.

**GUIDE TO APPLICATION**

1. **A-C Ripple Current:** The maximum allowable ripple current shall be determined from the formula:

$$I_{rms} = \sqrt{\frac{P}{R_{ESR}}}$$

where,

P = Power Dissipation in W at + 25 °C as given in the table in Paragraph Number 5 (Power Dissipation).

R<sub>ESR</sub> = The capacitor Equivalent Series Resistance at the specified frequency.

2. **A-C Ripple Voltage:** The maximum allowable ripple voltage shall be determined from the formula:

$$V_{rms} = I_{rms} \times Z$$

or, from the formula:

$$V_{rms} = Z \sqrt{\frac{P}{R_{ESR}}}$$

where,

P = Power Dissipation in W at + 25 °C as given in the table Power Dissipation

R<sub>ESR</sub> = The capacitor Equivalent Series Resistance at the specified frequency.

Z = The capacitor impedance at the specified frequency

- 2.1 The sum of the peak AC voltage plus the applied DC voltage shall not exceed the DC voltage rating of the capacitor.
- 2.2 The sum of the negative peak AC voltage plus the applied DC voltage shall not allow a voltage reversal exceeding 10 % of the DC working voltage at + 25 °C.
3. **Reverse Voltage:** These capacitors are capable of withstanding peak voltages in the reverse direction equal to 10 % of the DC rating at + 25 °C and 5 % of the DC rating at + 85 °C.
4. **Temperature Derating:** If these capacitors are to be operated at temperatures above + 25 °C, the permissible rms ripple current or voltage shall be calculated using the derating factors as shown:

Temperature	Derating Factor
+ 25 °C	1.0
+ 85 °C	0.9
+ 125 °C	0.4

5. **Power Dissipation:** Power dissipation will be affected by the heat sinking capability of the mounting surface. Non-sinusoidal ripple current may produce heating effects which differ from those shown. It is important that the equivalent Irmsvalue be established when calculating permissible operating levels. (Power dissipation calculated using + 25 °C temperature rise.)
6. **Attachment:**
  - 6.1 **Soldering:** Capacitors can be attached by conventional soldering techniques, convection, infrared reflow, wave soldering and hot plate methods. The Soldering Profile chart shows typical recommended time/temperature conditions for soldering. Preheating is recommended to reduce thermal stress. The recommended maximum preheat rate is 2 °C per second. Attachment with a soldering iron is not recommended due to the difficulty of controlling temperature and time at temperature. The soldering iron must never come in contact with the capacitor.
7. **Recommended Mounting Pad Geometries:** The nib must have sufficient clearance to avoid electrical contact with other components. The width dimension indicated is the same as the maximum width of the capacitor. This is to minimize lateral movement.
8. **Cleaning (Flux Removal) After Soldering:** Hi-Rel COTS capacitors are compatible with all commonly used solvents such as TES, TMS, Prelete, Chlorethane, Terpene and aqueous cleaning media. However, CFC/ODS products are not used in the production of these devices and are not recommended. Solvents containing methylene chloride or other epoxy solvents should be avoided since these will attack the epoxy encapsulation material.