



## Guide for MicroTan® Capacitors

### INTRODUCTION

Tantalum electrolytic capacitors are the preferred choice in applications where volumetric efficiency, stable electrical parameters, high reliability, and long service life are primary considerations. The stability and resistance to elevated temperatures of the tantalum/tantalum oxide/manganese dioxide system make solid tantalum capacitors an appropriate choice for today's surface mount assembly technology.

Vishay Sprague has been a pioneer and leader in this field, producing a large variety of tantalum capacitor types for consumer, industrial, automotive, military, and aerospace electronic applications.

Tantalum is not found in its pure state. Rather, it is commonly found in a number of oxide minerals, often in combination with Columbium ore. This combination is known as "tantallite" when its contents are more than one-half tantalum. Important sources of tantallite include Australia, Brazil, Canada, China, and several African countries. Synthetic tantallite concentrates produced from tin slags in Thailand, Malaysia, and Brazil are also a significant raw material for tantalum production.

Electronic applications, and particularly capacitors, consume the largest share of world tantalum production. Other important applications for tantalum include cutting tools (tantalum carbide), high temperature super alloys, chemical processing equipment, medical implants, and military ordnance.

Vishay Sprague is a major user of tantalum materials in the form of powder and wire for capacitor elements and rod and sheet for high temperature vacuum processing.

### THE BASICS OF TANTALUM CAPACITORS

Most metals form crystalline oxides which are non-protecting, such as rust on iron or black oxide on copper. A few metals form dense, stable, tightly adhering, electrically insulating oxides. These are the so-called "valve" metals and include titanium, zirconium, niobium, tantalum, hafnium, and aluminum. Only a few of these permit the accurate control of oxide thickness by electrochemical means. Of these, the most valuable for the electronics industry are aluminum and tantalum.

Capacitors are basic to all kinds of electrical equipment, from radios and television sets to missile controls and automobile ignitions. Their function is to store an electrical charge for later use.

Capacitors consist of two conducting surfaces, usually metal plates, whose function is to conduct electricity. They are separated by an insulating material or dielectric. The dielectric used in all tantalum electrolytic capacitors is tantalum pentoxide.

Tantalum pentoxide compound possesses high-dielectric strength and a high-dielectric constant. As capacitors are being manufactured, a film of tantalum pentoxide is applied to their electrodes by means of an electrolytic process. The film is applied in various thicknesses and at various voltages and although transparent to begin with, it takes on different

colors as light refracts through it. This coloring occurs on the tantalum electrodes of all types of tantalum capacitors.

Rating for rating, tantalum capacitors tend to have as much as three times better capacitance/volume efficiency than aluminum electrolytic capacitors. An approximation of the capacitance/volume efficiency of other types of capacitors may be inferred from the following table, which shows the dielectric constant ranges of the various materials used in each type. Note that tantalum pentoxide has a dielectric constant of 26, some three times greater than that of aluminum oxide. This, in addition to the fact that extremely thin films can be deposited during the electrolytic process mentioned earlier, makes the tantalum capacitor extremely efficient with respect to the number of microfarads available per unit volume. The capacitance of any capacitor is determined by the surface area of the two conducting plates, the distance between the plates, and the dielectric constant of the insulating material between the plates.

#### COMPARISON OF CAPACITOR DIELECTRIC CONSTANTS

DIELECTRIC	$\epsilon$ DIELECTRIC CONSTANT
Air or Vacuum	1.0
Paper	2.0 - 6.0
Plastic	2.1 - 6.0
Mineral Oil	2.2 - 2.3
Silicone Oil	2.7 - 2.8
Quartz	3.8 - 4.4
Glass	4.8 - 8.0
Porcelain	5.1 - 5.9
Mica	5.4 - 8.7
Aluminum Oxide	8.4
<b>Tantalum Pentoxide</b>	<b>26</b>
Ceramic	12 - 400K

In the tantalum electrolytic capacitor, the distance between the plates is very small since it is only the thickness of the tantalum pentoxide film. As the dielectric constant of the tantalum pentoxide is high, the capacitance of a tantalum capacitor is high if the area of the plates is large:

$$C = \frac{\epsilon A}{t}$$

where

- C = capacitance
- $\epsilon$  = dielectric constant
- A = surface area of the dielectric
- t = thickness of the dielectric

Tantalum capacitors contain either liquid or solid electrolytes. In solid electrolyte capacitors, a dry material (manganese dioxide) forms the cathode plate. A tantalum lead is embedded in or welded to the pellet, which is in turn connected to a termination or lead wire. The drawings show the construction details of the surface mount types of tantalum capacitors shown in this catalog.

**SOLID ELECTROLYTE TANTALUM CAPACITORS**

Solid electrolyte capacitors contain manganese dioxide, which is formed on the tantalum pentoxide dielectric layer by impregnating the pellet with a solution of manganous nitrate. The pellet is then heated in an oven, and the manganous nitrate is converted to manganese dioxide.

The pellet is next coated with graphite, followed by a layer of metallic silver.

Molded Chip tantalum capacitor encases the element in plastic resins, such as epoxy materials. After assembly, the capacitors are tested and inspected to assure long life and reliability. It offers excellent reliability and high stability for consumer and commercial electronics with the added feature of low cost.

Surface mount designs of "Solid Tantalum" capacitors use lead frames or lead frameless designs as shown in the accompanying drawings.

**TANTALUM CAPACITORS FOR ALL DESIGN CONSIDERATIONS**

Solid electrolyte designs are the least expensive for a given rating and are used in many applications where their very small size for a given unit of capacitance is of importance. They will typically withstand up to about 10 % of the rated DC working voltage in a reverse direction. Also important are their good low temperature performance characteristics and freedom from corrosive electrolytes.

Vishay Sprague patented the original solid electrolyte capacitors and was the first to market them in 1956. Vishay Sprague has the broadest line of tantalum capacitors and has continued its position of leadership in this field. Data sheets covering the various types and styles of Vishay Sprague capacitors for consumer and entertainment electronics, industry, and military applications are available where detailed performance characteristics must be specified.

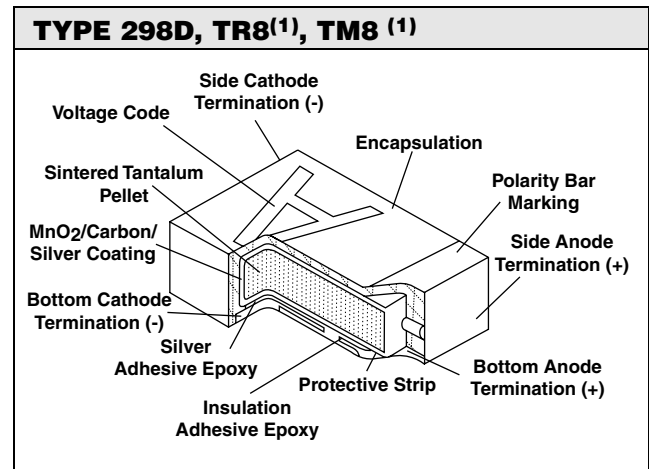
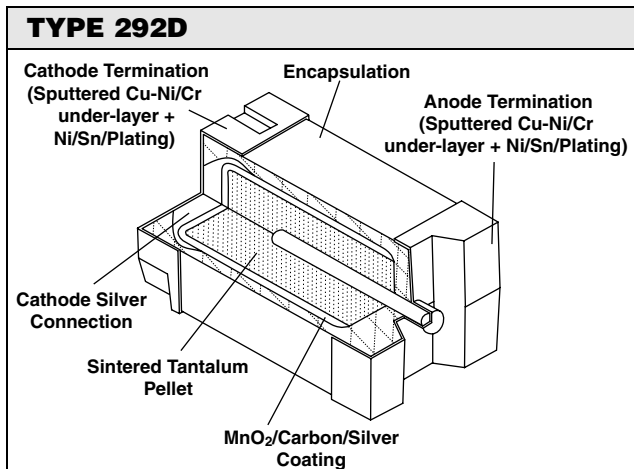

<b>SOLID TANTALUM CAPACITORS - MOLDED</b>		
<b>SERIES</b>	<b>292D</b>	<b>298D, TR8 (1), TM8 (1)</b>
<b>PRODUCT IMAGE</b>		
<b>TYPE</b>	TANTAMOUNT® Chip, Lead Frameless, Molded	MICRO TAN® Chip, Lead Frameless, Molded, Face-down Terminals,
<b>FEATURES</b>	Lead Frameless, Commercial, lead (Pb)-free, 0805, RoHS Compliant	Lead Frameless, Commercial, lead (Pb)-free, 0806, 0603, RoHS Compliant
<b>TEMPERATURE RANGE (°C)</b>	-55 °C to +125 °C	-55 °C to +125 °C
<b>CAPACITANCE RANGE (µF)</b>	1.0 µF to 47 µF	10 µF to 47 µF
<b>VOLTAGE RANGE (V)</b>	3 ~ 20	3 ~ 10
<b>CAPACITANCE TOLERANCE (%)</b>	± 20, ± 10	± 20
<b>LEAKAGE CURRENT (µA)</b>	0.01 CV or 0.5 µA Max.	0.01 CV or 0.5 µA Max.
<b>DISSIPATION FACTOR</b>	4 ~ 12 Max.	6 ~ 14 Max.
<b>CASE CODES</b>	P, R	M, R

**Note**

(1) Contact factory for availability

## PLASTIC TAPE AND REEL PACKAGING in inches [millimeters]

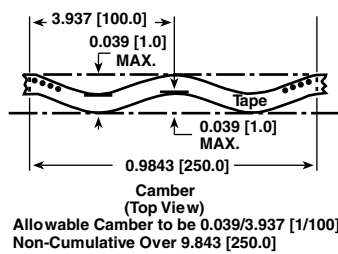
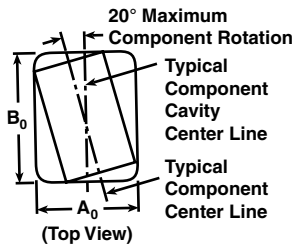
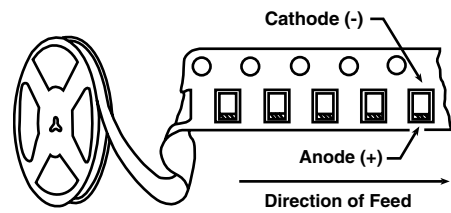
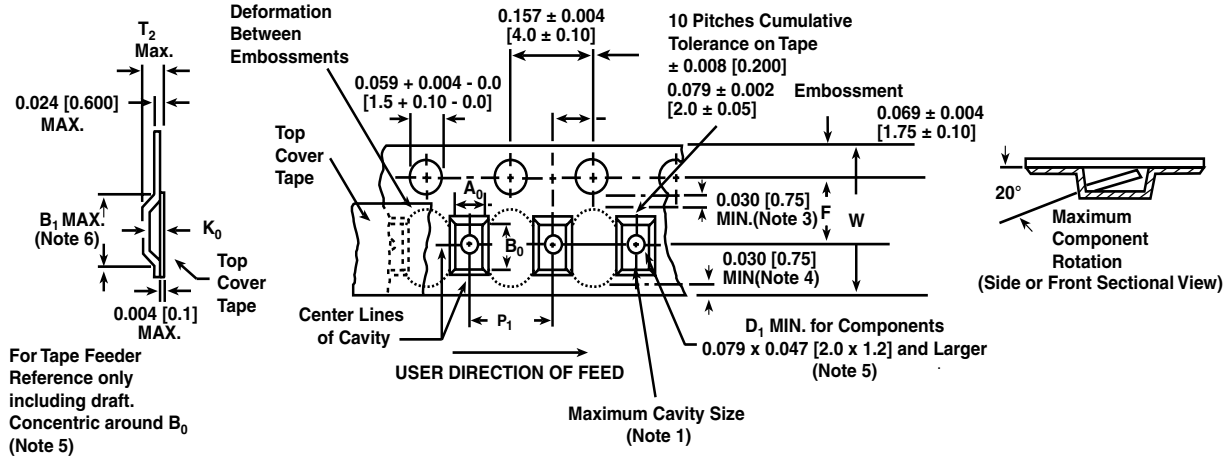

**Tape and Reel Specifications:** All case codes are available on plastic embossed tape per EIA-481-1. Tape reeling per IEC 286-3 is also available. Standard reel diameter is 7" [178 mm], 13" [330 mm] reels are available and recommended as the most cost effective packaging method.

The most efficient packaging quantities are full reel increments on a given reel diameter. The quantities shown allow for the sealed empty pockets required to be in conformance with EIA-481-1. Reel size and packaging orientation must be specified in the Vishay Sprague part number.

CASE CODE	TAPE SIZE	$B_1$ (MAX.)	$D_1$ (MIN.)	F	$K_0$ (MAX.)	$P_1$	W
292D, 298D, TM8 <sup>(1)</sup> , TR8 <sup>(1)</sup>							
M, P, A, D, E, F, T, R	8 mm	$0.092 \pm 0.0039$ [2.34 ± 0.100]	$0.0394 + 0.0098$ [1.5 + 0.100]	$0.1378 \pm 0.0098$ [3.5 ± 0.05]	$0.053 \pm 0.0039$ [1.35 + 0.100]	$0.1575 \pm 0.0039$ [4.0 ± 0.2]	$0.315 + 0.0118 - 0.0039$ [8.0 + 0.30 - 0.1]

### STANDARD PACKAGING QUANTITY

SERIES	CASE CODE	QTY (PCS/REEL)	
		7" REEL	13" REEL
292D	P, R	2500	10 000
298D, TM8 <sup>(1)</sup> , TR8 <sup>(1)</sup>	M	3000	10 000
	R	3000	80 000

**Note**

<sup>(1)</sup> Contact factory for availability

**RECOMMENDED VOLTAGE DERATING GUIDELINES**

STANDARD CONDITIONS: FOR EXAMPLE: OUTPUT FILTERS

Capacitor Voltage Rating	Operating Voltage
4.0	2.5
6.3	3.6
10	6.0
16	10
20	12
25	15
35	24
50	28

**RECOMMENDED VOLTAGE DERATING GUIDELINES**

SEVERE CONDITIONS: FOR EXAMPLE: INPUT FILTERS

Capacitor Voltage Rating	Operating Voltage
4.0	2.5
6.3	3.3
10	5.0
16	8.0
20	10
25	12
35	15
50	24

**POWER DISSIPATION**

CASE CODE		MAXIMUM PERMISSIBLE POWER DISSIPATION AT + 25 °C (W) IN FREE AIR
292D	P, R	0.025
298D TM8 <sup>(1)</sup> TR8 <sup>(1)</sup>	M, R	TBD

**Note**<sup>(1)</sup> Contact factory for availability

## RECOMMENDED REFLOW PROFILES

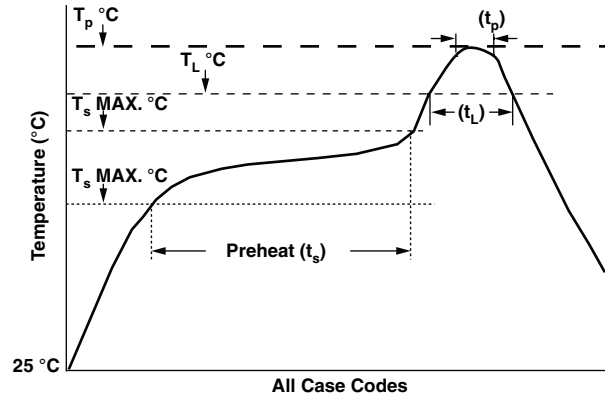

TYPE	T <sub>p</sub> lead (Pb)-free	T <sub>p</sub> Sn/Pb	t <sub>p</sub>	T <sub>L</sub> lead (Pb)-free	T <sub>L</sub> Sn/Pb	T <sub>s</sub> MIN. lead (Pb)-free	T <sub>s</sub> MIN. Sn/Pb	T <sub>s</sub> MAX. lead (Pb)-free	T <sub>s</sub> MAX. Sn/Pb	t <sub>s</sub> lead (Pb)-free	t <sub>s</sub> Sn/Pb	t <sub>L</sub>
292D	240 °C	225 °C	10	217 °C	217 °C	130 °C	130 °C	200 °C	200 °C	60 - 150	60 - 90	60
298D TM8 <sup>(1)</sup> TR8 <sup>(1)</sup>	240 °C	225 °C	10	217 °C	217 °C	130 °C	130 °C	200 °C	200 °C	60 - 150	60 - 90	60

## PAD DIMENSIONS in inches [millimeters]

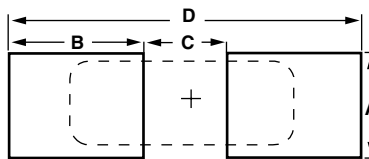

CASE CODE	A (MIN.)	B (NOM.)	C (NOM.)	D (NOM.)
292D				
P, R	0.059 [1.5]	0.02 [0.8]	0.039 [1.0]	0.079 [2.00]
298D, TM8 <sup>(1)</sup> , TR8 <sup>(1)</sup>				
M, P, A, D, E, F, T, R	0.026 [0.65]	0.02 [0.8]	0.065 [1.65]	0.079 [2.00]

**Note**

<sup>(1)</sup> Contact factory for availability



**GUIDE TO APPLICATION**

1. **A-C Ripple Current:** The maximum allowable ripple current shall be determined from the formula:

$$I_{rms} = \sqrt{\frac{P}{R_{ESR}}}$$

where,

P = Power Dissipation in Watts at + 25 °C as given in the table in Paragraph Number 5 (Power Dissipation).

R<sub>ESR</sub> = The capacitor Equivalent Series Resistance at the specified frequency.

2. **A-C Ripple Voltage:** The maximum allowable ripple voltage shall be determined from the formula:

$$V_{rms} = Z \sqrt{\frac{P}{R_{ESR}}}$$

or, from the formula:

$$V_{rms} = I_{rms} \times Z$$

where,

P = Power Dissipation in Watts at + 25 °C as given in the table in Paragraph Number 5 (Power Dissipation).

R<sub>ESR</sub> = The capacitor Equivalent Series Resistance at the specified frequency.

Z = The capacitor impedance at the specified frequency.

- 2.1 The sum of the peak AC voltage plus the applied DC voltage shall not exceed the DC voltage rating of the capacitor.
- 2.2 The sum of the negative peak AC voltage plus the applied DC voltage shall not allow a voltage reversal exceeding 10 % of the DC working voltage at + 25 °C.
3. **Reverse Voltage:** These capacitors are capable of withstanding peak voltages in the reverse direction equal to 10 % of the DC rating at + 25 °C, 5 % of the DC rating at + 85 °C and 1 % of the DC rating at + 125 °C.
4. **Temperature Derating:** If these capacitors are to be operated at temperatures above + 25 °C, the permissible rms ripple current or voltage shall be calculated using the derating factors as shown:

TEMPERATURE	DERATING FACTOR
+ 25 °C	1.0
+ 85 °C	0.9
+ 125 °C	0.4

5. **Power Dissipation:** Power dissipation will be affected by the heat sinking capability of the mounting surface. Non-sinusoidal ripple current may produce heating effects which differ from those shown. It is important that the equivalent I<sub>rms</sub> value be established when calculating permissible operating levels. (Power Dissipation calculated using + 25 °C temperature rise.)

6. **Printed Circuit Board Materials:** Molded capacitors are compatible with commonly used printed circuit board materials (alumina substrates, FR4, FR5, G10, PTFE-fluorocarbon and porcelanized steel).

7. **Attachment:**

- 7.1 **Solder Paste:** The recommended thickness of the solder paste after application is 0.007" ± 0.001" [0.178 mm ± 0.025 mm]. Care should be exercised in selecting the solder paste. The metal purity should be as high as practical. The flux (in the paste) must be active enough to remove the oxides formed on the metallization prior to the exposure to soldering heat. In practice this can be aided by extending the solder preheat time at temperatures below the liquidous state of the solder.

- 7.2 **Soldering:** Capacitors can be attached by conventional soldering techniques; vapor phase, convection reflow, infrared reflow, wave soldering and hot plate methods. The Soldering Profile charts show recommended time/temperature conditions for soldering. Preheating is recommended. The recommended maximum ramp rate is 2 °C per second. Attachment with a soldering iron is not recommended due to the difficulty of controlling temperature and time at temperature. The soldering iron must never come in contact with the capacitor.

- 7.2.1 **Backward and Forward Compatibility:** Capacitors with SnPb or 100 % tin termination finishes can be soldered using SnPb or lead (Pb)-free soldering processes.

8. **Cleaning (Flux Removal) After Soldering:** Molded capacitors are compatible with all commonly used solvents such as TES, TMS, Prelete, Chloroethane, Terpene and aqueous cleaning media. However, CFC/ODS products are not used in the production of these devices and are not recommended. Solvents containing methylene chloride or other epoxy solvents should be avoided since these will attack the epoxy encapsulation material.

- 8.1 When using ultrasonic cleaning, the board may resonate if the output power is too high. This vibration can cause cracking or a decrease in the adherence of the termination. DO NOT EXCEED 9W/l at 40 kHz for 2 minutes.

9. **Recommended Mounting Pad Geometries:** Proper mounting pad geometries are essential for successful solder connections. These dimensions are highly process sensitive and should be designed to minimize component rework due to unacceptable solder joints. The dimensional configurations shown are the recommended pad geometries for both wave and reflow soldering techniques. These dimensions are intended to be a starting point for circuit board designers and may be fine tuned if necessary based upon the peculiarities of the soldering process and/or circuit board design.