

Solid Tantalum Surface Mount Capacitors TANTAMOUNT[®], Molded Case, DSCC Approved, Low ESR



FEATURES

- Terminations: Gold and solder plated
- Molded case available in 3 case codes
- Meets MIL-PRF-55365 and EIA535BAAC mechanical and performance requirements
- High ripple current carrying capability
- Low ESR

Inspection: MIL-PRF-55365, group A inspection (exponential distribution); subgroups 1 and 3 with voltage aging a minimum of 10 h.

100 % Surge Current Tested

- Temperature: 25 °C
- Applied voltage: Rated voltage
- Test cycles: 4
- Charge and discharge cycles: 4 s maximum
- Total DC resistance: 0.6 Ω maximum

PERFORMANCE/ELECTRICAL CHARACTERISTICS

Operating Temperature: - 55 °C to + 125 °C
(above 85 °C, voltage derating is required)

Capacitance Range: 4.7 μF to 220 μF

Capacitance Tolerance: ± 10 %, and ± 20 %

Voltage Rating: 6 V_{DC} to 50 V_{DC}

ORDERING INFORMATION				
95158-	01	K	H	T
DRAWING NUMBER	DASH NUMBER	CAPACITANCE TOLERANCE	TERMINATION FINISH	PACKAGING
		K = ± 10 % M = ± 20 %	B = Gold plated (10 microinch minimum) H = Solder plated (100 microinch minimum)	T = 7" (178 mm) reel

DIMENSIONS in inches [millimeters]							
CASE CODE	EIA SIZE	L	W	H	P	T _w	T _H MIN.
C	6032-28	0.236 ± 0.012 [6.0 ± 0.30]	0.126 ± 0.012 [3.2 ± 0.30]	0.098 ± 0.012 [2.5 ± 0.30]	0.051 ± 0.012 [1.3 ± 0.30]	0.087 ± 0.004 [2.2 ± 0.10]	0.039 [1.0]
D	7343-31	0.287 ± 0.012 [7.3 ± 0.30]	0.170 ± 0.012 [4.3 ± 0.30]	0.110 ± 0.012 [2.8 ± 0.30]	0.051 ± 0.012 [1.3 ± 0.30]	0.095 ± 0.004 [2.4 ± 0.10]	0.039 [1.0]
E	7343-43	0.287 ± 0.012 [7.3 ± 0.30]	0.170 ± 0.012 [4.3 ± 0.30]	0.158 ± 0.012 [4.0 ± 0.30]	0.051 ± 0.012 [1.3 ± 0.30]	0.095 ± 0.004 [2.4 ± 0.10]	0.039 [1.0]

RATINGS AND CASE CODES							
μF	6 V	10 V	16 V	20 V	25 V	35 V	50 V
4.7						C	E
6.8						E	
10						D/E	
15				D	D/E	E	
22				D	E	E	
33			D		E		
47		D	D	E			
68	D	E		E			
100		D/E	E				
150	E	D/E					
220	D/E	E					

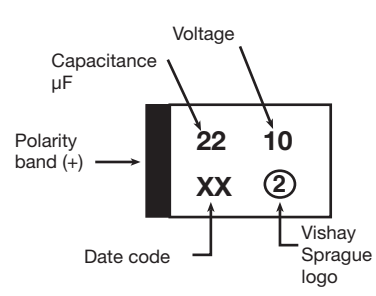
MARKING
 <p>“C, D, E” case sizes</p>
<p>Marking: Capacitor marking includes an anode (+) polarity band, capacitance in microfarads and the voltage rating. The Vishay Sprague® trademark is included if space permits. A manufacturing date code is marked on all capacitors. Call the factory for further explanation.</p>



STANDARD RATINGS										
CAPACITANCE (μ F)	CASE CODE	PART NUMBER	MAX. DC LEAKAGE (μ A)				MAX. DF (%)		MAX. ESR AT + 25 °C 100 kHz (Ω)	MAX. RIPPLE 100 kHz I_{RMS} (A)
			+ 25 °C	+ 85 °C	+ 125 °C	+ 25 °C	+ 85 °C + 125 °C	- 55 °C		
6 V_{DC} AT + 85 °C; 4 V_{DC} AT + 125 °C										
68	D	95158-01(1)(2)(3)	3.3	19.8	33.0	4	6	6	0.175	0.93
150	E	95158-02(1)(2)(3)	7.2	43.2	72.0	6	8	8	0.125	1.15
220	D	95158-25(1)(2)(3)	13.2	132.0	165.0	8	12	12	0.100	1.22
220	E	95158-03(1)(2)(3)	13.2	132.0	165.0	8	12	12	0.100	1.28
10 V_{DC} AT + 85 °C; 7 V_{DC} AT + 125 °C										
47	D	95158-04(1)(2)(3)	3.8	22.8	38.0	4	6	6	0.200	0.87
68	E	95158-05(1)(2)(3)	5.4	32.4	54.0	4	6	6	0.150	1.05
100	D	95158-06(1)(2)(3)	10.0	100.0	125.0	8	12	12	0.100	1.22
100	E	95158-07(1)(2)(3)	8.0	48.0	80.0	6	8	8	0.100	1.28
150	E	95158-08(1)(2)(3)	15.0	150.0	187.5	8	12	12	0.100	1.28
150	D	95158-26(1)(2)(3)	15.0	150.0	187.5	8	12	12	0.100	1.22
220	E	95158-28(1)(2)(3)	15.0	150.0	187.5	8	12	12	0.100	1.28
16 V_{DC} AT + 85 °C; 10 V_{DC} AT + 125 °C										
33	D	95158-09(1)(2)(3)	4.2	25.2	42.0	4	6	6	0.250	0.77
47	D	95158-10(1)(2)(3)	7.5	75.0	94.0	6	9	9	0.200	0.87
100	E	95158-11(1)(2)(3)	16.0	160.0	200.0	8	12	12	0.125	1.15
20 V_{DC} AT + 85 °C; 13 V_{DC} AT + 125 °C										
15	D	95158-12(1)(2)(3)	2.4	14.4	24.0	4	6	6	0.275	0.74
22	D	95158-13(1)(2)(3)	3.5	21.0	35.0	4	6	6	0.275	0.74
47	E	95158-14(1)(2)(3)	7.5	45.0	75.0	4	6	6	0.150	1.05
68	E	95158-15(1)(2)(3)	13.6	136.0	170.0	6	9	9	0.150	1.05
25 V_{DC} AT + 85 °C; 17 V_{DC} AT + 125 °C										
15	D	95158-16(1)(2)(3)	3.8	38.0	46.9	6	9	9	0.275	0.74
15	E	95158-17(1)(2)(3)	3.0	18.0	30.0	4	6	6	0.200	0.91
22	E	95158-18(1)(2)(3)	4.4	26.4	44.0	4	6	6	0.225	0.86
33	E	95158-19(1)(2)(3)	6.6	39.6	66.0	4	6	6	0.175	0.97
35 V_{DC} AT + 85 °C; 23 V_{DC} AT + 125 °C										
4.7	C	95158-29(1)(2)(3)	1.7	10.2	17.0	6	9	9	0.600	0.43
6.8	E	95158-20(1)(2)(3)	1.9	11.4	19.0	4	6	6	0.300	0.74
10	D	95158-27(1)(2)(3)	3.5	35.0	42.0	4	6	6	0.300	0.71
10	E	95158-21(1)(2)(3)	2.8	16.8	28.0	4	6	6	0.250	0.81
15	E	95158-22(1)(2)(3)	5.3	53.0	65.6	6	9	9	0.225	0.86
22	E	95158-23(1)(2)(3)	7.7	77.0	96.3	6	9	9	0.300	0.74
50 V_{DC} AT + 85 °C; 33 V_{DC} AT + 125 °C										
4.7	E	95158-24(1)(2)(3)	1.9	11.4	19.0	4	6	6	0.300	0.74

Note

- Part number definitions:
 (1) Tolerance: K, M
 (2) Termination finish: B, H
 (3) Packaging: T



Disclaimer

ALL PRODUCT, PRODUCT SPECIFICATIONS AND DATA ARE SUBJECT TO CHANGE WITHOUT NOTICE TO IMPROVE RELIABILITY, FUNCTION OR DESIGN OR OTHERWISE.

Vishay Intertechnology, Inc., its affiliates, agents, and employees, and all persons acting on its or their behalf (collectively, "Vishay"), disclaim any and all liability for any errors, inaccuracies or incompleteness contained in any datasheet or in any other disclosure relating to any product.

Vishay makes no warranty, representation or guarantee regarding the suitability of the products for any particular purpose or the continuing production of any product. To the maximum extent permitted by applicable law, Vishay disclaims (i) any and all liability arising out of the application or use of any product, (ii) any and all liability, including without limitation special, consequential or incidental damages, and (iii) any and all implied warranties, including warranties of fitness for particular purpose, non-infringement and merchantability.

Statements regarding the suitability of products for certain types of applications are based on Vishay's knowledge of typical requirements that are often placed on Vishay products in generic applications. Such statements are not binding statements about the suitability of products for a particular application. It is the customer's responsibility to validate that a particular product with the properties described in the product specification is suitable for use in a particular application. Parameters provided in datasheets and/or specifications may vary in different applications and performance may vary over time. All operating parameters, including typical parameters, must be validated for each customer application by the customer's technical experts. Product specifications do not expand or otherwise modify Vishay's terms and conditions of purchase, including but not limited to the warranty expressed therein.

Except as expressly indicated in writing, Vishay products are not designed for use in medical, life-saving, or life-sustaining applications or for any other application in which the failure of the Vishay product could result in personal injury or death. Customers using or selling Vishay products not expressly indicated for use in such applications do so at their own risk and agree to fully indemnify and hold Vishay and its distributors harmless from and against any and all claims, liabilities, expenses and damages arising or resulting in connection with such use or sale, including attorneys fees, even if such claim alleges that Vishay or its distributor was negligent regarding the design or manufacture of the part. Please contact authorized Vishay personnel to obtain written terms and conditions regarding products designed for such applications.

No license, express or implied, by estoppel or otherwise, to any intellectual property rights is granted by this document or by any conduct of Vishay. Product names and markings noted herein may be trademarks of their respective owners.

Material Category Policy

Vishay Intertechnology, Inc. hereby certifies that all its products that are identified as RoHS-Compliant fulfill the definitions and restrictions defined under Directive 2011/65/EU of The European Parliament and of the Council of June 8, 2011 on the restriction of the use of certain hazardous substances in electrical and electronic equipment (EEE) - recast, unless otherwise specified as non-compliant.

Please note that some Vishay documentation may still make reference to RoHS Directive 2002/95/EC. We confirm that all the products identified as being compliant to Directive 2002/95/EC conform to Directive 2011/65/EU.