

Wet Tantalum Capacitors Cylindrical Body, Hermetically Sealed



FEATURES

- High temperature
- High voltage
- High capacitance
- Withstands high frequency vibration to 2000 Hz
- Hermetically sealed
- Long shelf life
- DSCC drawings 04032 and 04033
- Mounting: Arrays and assemblies

PERFORMANCE CHARACTERISTICS

Operating Temperature: - 55 °C to + 175 °C with proper derating

Voltage Range: 8 V_{DC} to 630 V_{DC} at 85 °C

Reverse Voltage: None

Capacitance Range: 2 μF to 2200 μF

Tolerance Range:

- 15 % to + 50 % (standard for XTK, XTM, XTV)
- 15 % to + 75 % (standard for XTH, XTL)
- ± 20 % (special order)

ORDERING INFORMATION						
XTV	126	T	630	P	0	A
MODEL	CAPACITANCE CODE	CAPACITANCE TOLERANCE	DC VOLTAGE RATING	CASE CODE	INSULATION	TERMINAL CONFIGURATION
XTH XTK XTL XTM XTV	This is expressed in picofarads. The first two digits are the significant figures. The third is the number of zeros to follow.	T = - 15 % to + 50 % (XTK, XTM, XTV standard) U = - 15 % to + 75 % (XTH, XTL standard) M = ± 20 % (special order)	This is expressed in volts. To complete the three-digit block, zeros precede the voltage rating.	P = Polar (case negative) R = Reverse polarity (case positive)	0 = Uninsulated (standard) 4 = Teflon (+ 175 °C limit)	See Styles

Note

- For styles, terminal configurations, mounting methods and hardware, please see pages following standard ratings table

DIMENSIONS in inches [millimeters]	
<p>XTH-XTL-XTV</p>	<p>XTK-XTM</p>
TYPE	D
XTK - XTM	0.656
XTL - XTH	0.875
XTV	1.125
	H
	0.438 to 1.781
	0.540 to 4.062
	0.600 to 2.810



STANDARD RATINGS AND DIMENSIONS															
CAPACITANCE (μ F)	MAX. WORKING VOLTAGE		TYP. ESR (Ω)	MAX. DCL AT MAX. V_{DC} (μ A)			MAX. Z -55 °C (Ω)	MAX. % CAP. CHANGE FROM ROOM TEMP.			APPROX. WEIGHT (g)	MAX. RIPPLE 120 Hz RMS -55 °C TO +175 °C (mA)	SIZE		PART NUMBER
	+125 °C +175 °C			+85 °C +125 °C +175 °C				-55 °C +85 °C +175 °C					D	H	
8 V_{DC} AT +85 °C															
70	7	5	10.0	30	45	60	60	-60	+30	+30	14	137	0.656	0.438	XTK706(1)008POA
140	7	5	5.0	50	75	100	30	-60	+30	+30	15	213	0.656	0.562	XTM147(1)008POA
10 V_{DC} AT +85 °C															
50	8.5	7	10.0	25	37	50	75	-60	+30	+30	14	137	0.656	0.438	XTK506(1)010POA
100	8.5	7	5.0	45	67	90	40	-60	+30	+30	15	213	0.656	0.562	XTM107(1)010POA
12 V_{DC} AT +85 °C															
580	10	8	1.5	135	197	270	20	-90	+20	+35	48	550	1.125	0.600	XTV587(1)012P0A
850	10	8	1.5	135	197	270	20	-90	+20	+35	50	550	1.125	0.600	XTV857(1)012P0A
1100	10	8	1.5	135	197	270	20	-90	+20	+35	60	694	1.125	1.100	XTV118(1)012P0A
2200	10	8	1.5	135	197	270	20	-90	+20	+35	82	694	1.125	1.100	XTV228(1)012P0A
18 V_{DC} AT +85 °C															
35	15	12	10.0	30	45	60	85	-60	+30	+30	14	137	0.656	0.438	XTK356(1)018P0A
70	15	12	5.0	50	75	100	45	-60	+30	+30	15	213	0.656	0.562	XTM706(1)018P0A
120	15	12	2.8	50	75	100	30	-60	+15	+40	26	328	0.875	0.540	XTL127(1)018P0A
240	15	12	2.5	80	120	160	20	-60	+15	+40	32	390	0.875	0.732	XTH247(1)018P0A
390	15	12	1.5	165	227	330	20	-85	+20	+35	48	550	1.125	0.600	XTV397(1)018P0A
560	15	12	1.5	165	227	330	20	-85	+20	+35	50	550	1.125	0.600	XTV567(1)018P0A
900	15	12	1.5	165	227	330	20	-85	+20	+35	68	694	1.125	1.100	XTV907(1)018P0A
1800	15	12	1.5	165	227	330	20	-85	+20	+35	82	694	1.125	1.100	XTV188(1)018P0A
20 V_{DC} AT +85 °C															
28	17.5	13	10.0	30	45	60	85	-60	+30	+30	14	137	0.656	0.438	XTK286(1)020P0A
56	17.5	13	5.0	50	75	100	45	-60	+30	+30	15	213	0.656	0.562	XTM566(1)020P0A
100	17.5	13	2.8	50	75	100	30	-60	+15	+40	26	328	0.875	0.540	XTL107(1)020P0A
200	17.5	13	2.5	80	120	160	20	-60	+15	+40	32	390	0.875	0.732	XTH207(1)020P0A
30 V_{DC} AT +85 °C															
20	25	20	10.0	35	52	70	125	-40	+20	+20	14	137	0.656	0.438	XTK206(1)030P0A
40	25	20	5.0	60	90	120	75	-40	+20	+20	15	213	0.656	0.562	XTM406(1)030P0A
75	25	20	2.7	55	82	110	45	-45	+15	+30	26	333	0.875	0.540	XTL756(1)030P0A
150	25	20	2.7	90	135	180	30	-45	+15	+30	32	375	0.875	0.732	XTH157(1)030P0A
250	25	20	2.5	195	287	390	20	-65	+20	+35	48	427	1.125	0.600	XTV257(1)030P0A
370	25	20	1.5	125	170	215	15	-65	+20	+35	50	550	1.125	0.600	XTV377(1)030P0A
650	25	20	1.5	145	202	250	15	-85	+20	+35	68	694	1.125	1.100	XTV657(1)030P0A
1300	25	20	1.5	190	282	375	10	-85	+20	+35	82	694	1.125	1.100	XTV138(1)030P0A
35 V_{DC} AT +85 °C															
20	30	23	10.0	35	52	72	125	-40	+20	+20	14	137	0.656	0.438	XTK206(1)035P0A
40	30	23	5.0	60	90	120	75	-40	+20	+20	15	213	0.656	0.562	XTM406(1)035P0A
60	30	23	2.7	55	82	110	45	-45	+10	+30	26	333	0.875	0.540	XTL606(1)035P0A

Note

- Part number definitions:
 - (1) Tolerance code:
 - T = -15 % to +50 % (standard for XTK, XTM, XTV)
 - U = -15 % to +75 % (standard for XTH, XTL)
 - M = \pm 20 % (available by special order)



STANDARD RATINGS AND DIMENSIONS															
CAPACITANCE (μ F)	MAX. WORKING VOLTAGE		TYP. ESR (Ω)	MAX. DCL AT MAX. V _{DC} (μ A)			MAX. Z -55 °C (Ω)	MAX. % CAP. CHANGE FROM ROOM TEMP.			APPROX. WEIGHT (g)	MAX. RIPPLE 120 Hz RMS -55 °C TO +175 °C (mA)	SIZE		PART NUMBER
	+125 °C	+175 °C		+85 °C	+125 °C	+175 °C		-55 °C	+85 °C	+175 °C			D +0.031 -0.015	H +0.062 -0.062	
40 V_{DC} AT +85 °C															
190	34	27	2.5	195	297	400	20	-55	+20	+35	48	427	1.125	0.600	XTV197(1)040POA
290	34	27	2.5	200	300	400	20	-55	+20	+35	50	427	1.125	0.600	XTV297(1)040POA
500	34	27	1.5	200	300	400	20	-75	+20	+35	68	694	1.125	1.100	XTV507(1)040POA
1000	34	27	1.5	195	297	400	20	-75	+20	+35	82	694	1.125	1.100	XTV108(1)040POA
50 V_{DC} AT +85 °C															
900	44	32	1.5	195	297	400	25	-85	+20	+35	82	694	1.125	1.100	XTV907(1)050POA
60 V_{DC} AT +85 °C															
12	50	40	10.0	35	52	70	180	-30	+20	+20	14	137	0.656	0.438	XTK126(1)060POA
25	50	40	5.0	60	90	120	90	-30	+20	+20	15	213	0.656	0.562	XTM256(1)060POA
40	50	40	2.7	60	90	120	65	-35	+10	+20	26	333	0.875	0.540	XTL406(1)060POA
70	50	40	2.7	90	135	180	40	-35	+10	+20	32	375	0.875	0.732	XTH706(1)060POA
80	50	40	2.7	95	142	190	35	-35	+10	+20	32	375	0.875	0.732	XTH806(1)060POA
130	50	40	2.5	210	315	420	30	-50	+20	+35	48	427	1.125	0.600	XTV137(1)060POA
200	50	40	1.5	135	182	230	30	-50	+20	+35	50	550	1.125	0.600	XTV207(1)060POA
350	50	40	1.5	155	210	265	25	-70	+20	+35	68	694	1.125	1.100	XTV357(1)060POA
700	50	40	1.5	200	275	350	15	-70	+20	+35	82	694	1.125	1.100	XTV707(1)060POA
750	50	40	1.5	200	275	350	29	-70	+20	+35	82	694	1.125	1.100	XTV757(1)060POA
90 V_{DC} AT +85 °C															
8.0	80	60	10.0	35	52	70	250	-30	+20	+20	14	137	0.656	0.438	XTK805(1)090POA
16	80	60	5.0	60	90	120	125	-30	+20	+20	15	213	0.656	0.562	XTM166(1)090POA
25	80	60	2.7	55	82	110	90	-35	+10	+20	26	333	0.875	0.540	XTL256(1)090POA
50	80	60	2.7	90	135	180	45	-35	+10	+20	32	375	0.875	0.732	XTH506(1)090POA
84	80	60	2.5	195	287	390	40	-40	+20	+35	48	427	1.125	0.600	XTV846(1)090POA
120	80	60	1.5	135	182	230	40	-40	+20	+35	50	550	1.125	0.600	XTV127(1)090POA
220	80	60	1.5	145	202	250	30	-60	+20	+35	68	694	1.125	1.100	XTV227(1)090POA
450	80	60	1.5	195	215	235	25	-60	+20	+35	82	694	1.125	1.100	XTV457(1)090POA
180 V_{DC} AT +85 °C															
2.0	160	120	20.0	75	112	150	850	-30	+20	+20	21	108	0.656	0.719	XTK205(1)180POA
4.0	160	120	20.0	35	52	70	500	-30	+20	+20	21	117	0.656	0.719	XTK405(1)180POA
8.0	160	120	10.0	60	90	120	250	-30	+20	+20	23	186	0.656	0.938	XTM805(1)180POA
12	160	120	5.6	55	82	110	180	-35	+10	+20	44	282	0.875	0.920	XTL126(1)180POA
25	160	120	5.3	90	135	180	90	-35	+10	+20	56	341	0.875	1.300	XTH256(1)180POA
42	160	120	5.0	120	162	205	75	-40	+20	+35	74	363	1.125	0.976	XTV426(1)180POA
60	160	120	3.0	135	182	230	60	-40	+20	+35	78	363	1.125	0.976	XTV606(1)180POA
110	160	120	3.0	145	202	250	60	-60	+20	+35	114	631	1.125	1.938	XTV117(1)180POA
230	160	120	3.0	200	275	350	50	-60	+20	+35	142	631	1.125	1.938	XTV237(1)180POA

Note

- Part number definitions:
 - (1) Tolerance code:
 - T = -15 % to +50 % (standard for XTK, XTM, XTV)
 - U = -15 % to +75 % (standard for XTH, XTL)
 - M = \pm 20 % (available by special order)



STANDARD RATINGS AND DIMENSIONS															
CAPACITANCE (μ F)	MAX. WORKING VOLTAGE + 125 °C + 175 °C	TYP. ESR (Ω)	MAX. DCL AT MAX. V _{DC} (μ A)			MAX. Z -55 °C (Ω)	MAX. % CAP. CHANGE FROM ROOM TEMP.			APPROX. WEIGHT (g)	MAX. RIPPLE 120 Hz RMS -55 °C TO +175 °C (mA)	SIZE		PART NUMBER	
			+85 °C	+125 °C	+175 °C		-55 °C	+85 °C	+175 °C			D +0.031 -0.015	H +0.062 -0.062		
270 V_{DC} AT +85 °C															
2.5	240	180	30.0	35	52	70	750	-30	+20	+20	28	112	0.656	1.031	XTK255(1)270POA
5.0	240	180	15.0	55	82	110	375	-30	+20	+20	31	179	0.656	1.375	XTM505(1)270POA
8.0	240	180	8.3	55	82	110	270	-35	+10	+20	62	266	0.875	1.270	XTL805(1)270POA
16	240	180	8.3	90	135	180	135	-35	+10	+20	81	320	0.875	1.865	XTH166(1)270POA
28	240	180	7.5	120	162	205	80	-40	+20	+35	100	339	1.125	1.350	XTV286(1)270POA
40	240	180	7.5	135	182	230	100	-40	+20	+35	104	339	1.125	1.350	XTV406(1)270POA
75	240	180	4.5	145	202	250	90	-60	+20	+35	160	608	1.125	2.812	XTV756(1)270POA
150	240	180	4.5	195	215	235	75	-60	+20	+35	202	608	1.125	2.812	XTV157(1)270POA
360 V_{DC} AT +85 °C															
2.0	320	240	40.0	35	52	70	1000	-30	+20	+20	37	108	0.656	1.312	XTK205(1)360POA
4.0	320	240	20.0	60	90	120	500	-30	+20	+20	41	175	0.656	1.781	XTM405(1)360POA
6.0	320	240	11.0	55	82	110	360	-35	+10	+20	80	258	0.875	1.635	XTL605(1)360POA
12	320	240	11.0	90	135	180	180	-35	+10	+20	105	314	0.875	2.420	XTH126(1)360POA
22	320	240	10.0	125	170	215	100	-40	+20	+35	126	323	1.125	1.705	XTV226(1)360POA
30	320	240	10.0	135	182	230	120	-40	+20	+35	133	323	1.125	1.705	XTV306(1)360POA
450 V_{DC} AT +85 °C															
5.0	400	300	13.0	55	82	110	450	-35	+10	+20	98	262	0.875	2.000	XTL505(1)450POA
10	400	300	13.0	90	135	180	225	-35	+10	+20	130	318	0.875	2.980	XTH106(1)450POA
17	400	300	12.5	125	170	215	130	-40	+20	+35	152	315	1.125	2.080	XTV176(1)450POA
25	400	300	12.5	135	182	230	150	-40	+20	+35	164	315	1.125	2.080	XTV256(1)450POA
540 V_{DC} AT +85 °C															
4.0	480	360	16.6	55	82	110	540	-35	+10	+20	114	250	0.875	2.365	XTL405(1)540POA
8.0	480	360	16.6	90	135	180	270	-35	+10	+20	154	306	0.875	3.532	XTH805(1)540POA
14	480	300	15.0	120	162	205	160	-40	+20	+35	178	309	1.125	2.435	XTV146(1)540POA
20	480	300	15.0	135	182	230	170	-40	+20	+35	196	309	1.125	2.435	XTV206(1)540POA
630 V_{DC} AT +85 °C															
3.5	560	420	18.9	55	82	110	630	-35	+10	+20	133	249	0.875	2.720	XTL355(1)630POA
7.0	560	420	18.9	90	135	180	315	-35	+10	+20	179	308	0.875	4.062	XTH705(1)630POA
12	560	420	17.5	120	162	205	180	-40	+20	+35	204	306	1.125	2.810	XTV126T630POA
18	560	420	17.5	135	182	230	200	-40	+20	+35	225	306	1.125	2.810	XTV186(1)630POA

Note

- Part number definitions:
 - (1) Tolerance code:
 - T = - 15 % to + 50 % (standard for XTK, XTM, XTV)
 - U = -15 % to + 75 % (standard for XTH, XTL)
 - M = \pm 20 % (available by special order)

XTH-L-V STYLES		
<p>STYLE A</p> <p>Top Bottom</p>	<p>STYLE B</p> <p>Top Bottom</p>	<p>STYLE C</p> <p>Top Bottom</p>
<p>STYLE D</p> <p>Top Bottom</p> <p>Negative screw lug is for indexing and negative connection only</p>	<p>STYLE E</p> <p>Top Bottom</p> <p>See Detail C in Mounting Methods table for suggested mounting methods</p>	<p>STYLE F</p> <p>Top Bottom</p> <p>See Detail D in Mounting Methods table for suggested mounting method</p>
<p>STYLE G</p> <p>Top Bottom</p> <p>Negative screw lug is for index and negative connection only</p>	<p>STYLE H</p> <p>Top Bottom</p> <p>See Detail C in Mounting Methods table for suggested mounting methods</p>	<p>STYLE J</p> <p>Top Bottom</p> <p>See Detail D in Mounting Methods table for suggested mounting methods</p>
<p>STYLE K</p> <p>Top Bottom</p> <p>See Details B and E in Mounting Methods table for suggested mounting methods</p>	<p>STYLE L</p> <p>Top Bottom</p> <p>See Detail B and E in Mounting Methods table for suggested mounting methods</p>	<p>STYLE M</p> <p>Top Bottom</p> <p>* Extends 0.125 on 0.875 DIA. units only</p>

XTK-M STYLES			
STYLE A <p>POS NEG</p>	STYLE B <p>POS NEG</p>	STYLE C <p>POS NEG</p>	STYLE D <p>POS NEG</p>
STYLE E <p>POS NEG</p>	STYLE F <p>POS NEG</p>	STYLE G <p>POS NEG</p>	STYLE H <p>POS NEG</p>

POSITIVE TERMINALS FOR XTK AND XTM			
STYLE A 	STYLE B, C AND D <p>Terminal detail enlarged</p>	STYLE E, G AND H 	STYLE F

NEGATIVE TERMINALS FOR XTK AND XTM			
STYLE A 	STYLE B, E AND F <p>Case negative</p>	STYLE C AND G 	STYLE D AND H

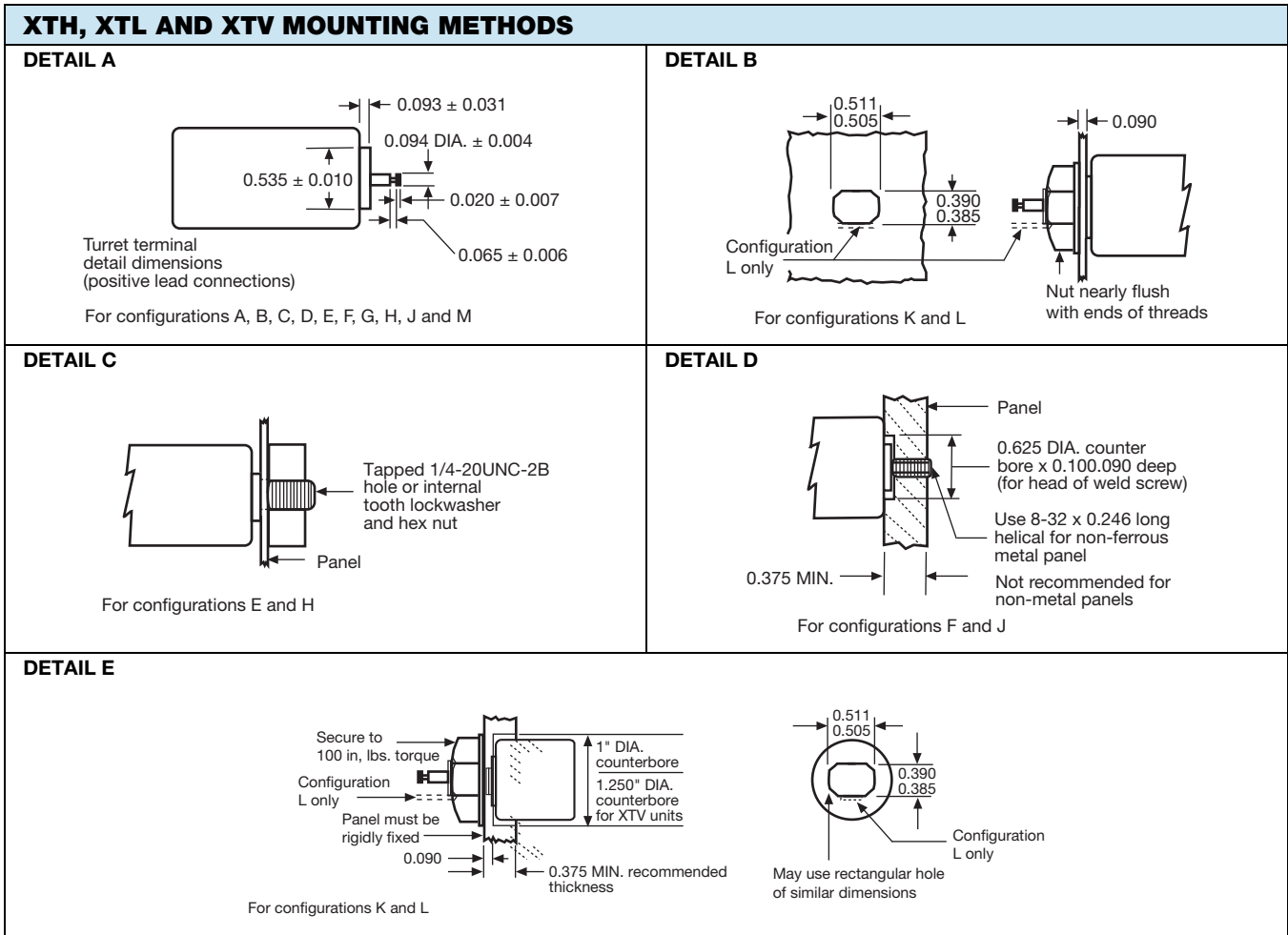

Note

- Standard mounting nut provided is plated steel. Stainless steel nut can be obtained by adding "/STN" suffix to part number.

04022 RATINGS AND CASE CODES													
DSCC DRAWING 04022 PIN	CAP. (NOM.) (µF)	CAP. TOLERANCE (%)	DC LEAKAGE MAX. (µA)			ESR MAX. 120 Hz 25 °C (Ω)	IMPEDANCE MAX. (Ω)	CAPACITANCE CHANGE (%)			RIPPLE CURRENT 1/ (mA)	DIMENSION L ± 0.062 (1.57) (INCHES)	FIGURE
			+ 25 °C	+ 85 °C	+ 125 °C			- 55 °C	+ 85 °C	+ 125 °C			
8 V_{DC} AT + 85 °C RATED; 9.2 V_{DC} AT + 85 °C SURGE													
01	70	+ 50, - 15	6	30	48	12	60	- 60	+ 30	+ 30	137	0.438 (11.13)	1A
02	140	+ 50, - 15	10	50	80	5.9	30	- 60	+ 30	+ 30	213	0.562 (14.27)	1A
10 V_{DC} AT + 85 °C RATED; 11.5 V_{DC} AT + 85 °C SURGE													
03	50	+ 50, - 15	5	25	40	11.7	75	- 60	+ 30	+ 30	137	0.438 (11.13)	1A
04	100	+ 50, - 15	9	45	72	5.9	40	- 60	+ 30	+ 30	213	0.562 (14.27)	1A
20 V_{DC} AT + 85 °C RATED; 23 V_{DC} AT + 85 °C SURGE													
05	28	+ 50, - 15	6	30	48	12	85	- 40	+ 20	+ 20	137	0.438 (11.13)	1A
06	56	+ 50, - 15	10	50	80	6	45	- 40	+ 20	+ 20	213	0.562 (14.27)	1A
30 V_{DC} AT + 85 °C RATED; 34.5 V_{DC} AT + 85 °C SURGE													
07	20	+ 50, - 15	7	35	56	11.7	125	- 40	+ 20	+ 20	137	0.438 (11.13)	1A
08	40	+ 50, - 15	12	60	96	5.9	75	- 40	+ 20	+ 20	213	0.562 (14.27)	1A



04022 RATINGS AND CASE CODES													
DSCC DRAWING 04022 PIN	CAP. (NOM.) (μF)	CAP. TOLERANCE (%)	DC LEAKAGE MAX. (μA)			ESR MAX. 120 Hz 25 °C (Ω)	IMPEDANCE MAX. (Ω)	CAPACITANCE CHANGE (%)			RIPPLE CURRENT 1/ (mA)	DIMENSION L ± 0.062 (1.57) (INCHES)	FIGURE
			+ 25 °C	+ 85 °C	+ 125 °C			- 55 °C	+ 85 °C	+ 125 °C			
60 V_{DC} AT + 85 °C RATED; 69 V_{DC} AT + 85 °C SURGE													
09	12	+ 50, - 15	7	35	56	12	180	- 30	+ 20	+ 20	137	0.438 (11.13)	1A
10	25	+ 50, - 15	12	60	96	6	90	- 30	+ 20	+ 20	213	0.562 (14.27)	1A
90 V_{DC} AT + 85 °C RATED; 103 V_{DC} AT + 85 °C SURGE													
11	8.0	+ 50, - 15	7	35	56	12	250	- 30	+ 20	+ 20	137	0.438 (11.13)	1A
12	16	+ 50, - 15	12	60	96	5.9	125	- 30	+ 20	+ 20	213	0.562 (14.27)	1A
180 V_{DC} AT + 85 °C RATED; 207 V_{DC} AT + 85 °C SURGE													
13	4.0	+ 50, - 15	7	35	56	24	500	- 30	+ 20	+ 20	117	0.719 (18.26)	1A
14	8.0	+ 50, - 15	12	60	96	12	250	- 30	+ 20	+ 20	186	0.938 (23.83)	1A
270 V_{DC} AT + 85 °C RATED; 310 V_{DC} AT + 85 °C SURGE													
15	2.5	+ 50, - 15	7	35	56	36	750	- 30	+ 20	+ 20	112	1.031 (26.19)	1A
16	5.0	+ 50, - 15	11	55	88	18	375	- 30	+ 20	+ 20	179	1.375 (34.93)	1A
360 V_{DC} AT + 85 °C RATED; 414 V_{DC} AT + 85 °C SURGE													
17	2.0	+ 50, - 15	7	35	56	48	1000	- 30	+ 20	+ 20	108	1.312 (33.32)	1A
18	4.0	+ 50, - 15	12	60	96	24	500	- 30	+ 20	+ 20	175	1.781 (45.24)	1A
20 V_{DC} AT + 85 °C RATED; 23 V_{DC} AT + 85 °C SURGE													
19	100	+ 50, - 15	10	50	80	3.3	30	- 60	+ 15	+ 20	333	0.540 (13.72)	1B
20	200	+ 75, - 15	16	80	128	2.8	20	- 60	+ 15	+ 20	375	0.732 (18.59)	1B
30 V_{DC} AT + 85 °C RATED; 34.5 V_{DC} AT + 85 °C SURGE													
21	75	+ 75, - 15	11	55	88	3.1	45	- 45	+ 10	+ 10	333	0.540 (13.72)	1B
22	150	+ 75, - 15	13	90	104	3	30	- 45	+ 10	+ 10	375	0.732 (18.59)	1B
60 V_{DC} AT + 85 °C RATED; 69 V_{DC} AT + 85 °C SURGE													
23	40	+ 75, - 15	12	60	96	3.2	65	- 35	+ 10	+ 10	333	0.540 (13.72)	1B
24	80	+ 75, - 15	19	95	152	3.1	35	- 35	+ 10	+ 10	375	0.732 (18.59)	1B
90 V_{DC} AT + 85 °C RATED; 103 V_{DC} AT + 85 °C SURGE													
25	25	+ 75, - 15	11	55	88	3.2	90	- 35	+ 10	+ 10	333	0.540 (13.72)	1B
26	50	+ 75, - 15	18	90	144	3.1	45	- 35	+ 10	+ 10	375	0.732 (18.59)	1B
180 V_{DC} AT + 85 °C RATED; 207 V_{DC} AT + 85 °C SURGE													
27	12	+ 75, - 15	11	55	88	6.6	180	- 35	+ 10	+ 10	282	0.920 (23.37)	1B
28	25	+ 75, - 15	18	90	144	6.2	90	- 35	+ 10	+ 10	341	1.300 (33.02)	1B
270 V_{DC} AT + 85 °C RATED; 310 V_{DC} AT + 85 °C SURGE													
29	8.0	+ 75, - 15	11	55	88	9.9	270	- 35	+ 10	+ 10	266	1.270 (32.36)	1B
30	16	+ 75, - 15	18	90	144	9.8	135	- 35	+ 10	+ 10	320	1.865 (47.37)	1B
360 V_{DC} AT + 85 °C RATED; 414 V_{DC} AT + 85 °C SURGE													
31	6.0	+ 75, - 15	11	55	88	13	360	- 35	+ 10	+ 10	258	1.635 (41.53)	1B
32	12	+ 75, - 15	18	90	144	13	180	- 35	+ 10	+ 10	314	2.420 (61.47)	1B
450 V_{DC} AT + 85 °C RATED; 518 V_{DC} AT + 85 °C SURGE													
33	5.0	+ 75, - 15	11	55	88	15	450	- 35	+ 10	+ 10	252	2.000 (50.80)	1B
34	10	+ 75, - 15	18	90	144	15	225	- 35	+ 10	+ 10	308	2.980 (75.69)	1B
540 V_{DC} AT + 85 °C RATED; 621 V_{DC} AT + 85 °C SURGE													
35	4.0	+ 75, - 15	11	55	88	20	540	- 35	+ 10	+ 10	250	2.365 (60.07)	1B
36	8.0	+ 75, - 15	18	90	144	20	270	- 35	+ 10	+ 10	308	3.532 (89.71)	1B
630 V_{DC} AT + 85 °C RATED; 724 V_{DC} AT + 85 °C SURGE													
37	3.5	+ 75, - 15	11	55	88	22	630	- 35	+ 10	+ 10	250	2.720 (69.09)	1B



04022 RATINGS AND CASE CODES													
DSCC DRAWING 04022 PIN	CAP. (NOM.) (µF)	CAP. TOLERANCE (%)	DC LEAKAGE MAX. (µA)			ESR MAX. 120 Hz 25 °C (Ω)	IMPEDANCE MAX. (Ω)	CAPACITANCE CHANGE (%)			RIPPLE CURRENT 1/ (mA)	DIMENSION L ± 0.062 (1.57) (INCHES)	FIGURE
			+ 25 °C	+ 85 °C	+ 125 °C			- 55 °C	+ 85 °C	+ 125 °C			
			30 V _{DC} AT + 85 °C RATED; 34.5 V _{DC} AT + 85 °C SURGE										
39	370	± 20	18	125	180	1.7	15	- 65	+ 20	+ 25	550	0.600 (15.24)	1C
40	370	+ 50, - 15	18	125	180	1.7	15	- 65	+ 20	+ 25	550	0.600 (15.24)	1C
41	650	± 20	21	145	210	1.8	15	- 85	+ 20	+ 25	694	1.100 (27.94)	1C
42	650	+ 50, - 15	21	145	210	1.8	15	- 85	+ 20	+ 25	694	1.100 (27.94)	1C
43	1300	± 20	27	190	270	1.8	10	- 85	+ 20	+ 25	694	1.100 (27.94)	1C
44	1300	+ 50, - 15	27	190	270	1.8	10	- 85	+ 20	+ 25	694	1.100 (27.94)	1C
60 V _{DC} AT + 85 °C RATED; 69 V _{DC} AT + 85 °C SURGE													
45	200	± 20	19	135	190	1.8	30	- 50	+ 20	+ 25	550	0.600 (15.24)	1C
46	200	+ 50, - 15	19	135	190	1.8	30	- 50	+ 20	+ 25	550	0.600 (15.24)	1C
47	350	± 20	22	155	220	1.8	25	- 70	+ 20	+ 25	694	1.100 (27.94)	1C
48	350	+ 50, - 15	22	155	220	1.8	25	- 70	+ 20	+ 25	694	1.100 (27.94)	1C
49	700	± 20	29	200	290	1.8	15	- 70	+ 20	+ 25	694	1.100 (27.94)	1C
50	700	+ 50, - 15	29	200	290	1.8	15	- 70	+ 20	+ 25	694	1.100 (27.94)	1C
90 V _{DC} AT + 85 °C RATED; 103 V _{DC} AT + 85 °C SURGE													
51	120	± 20	19	135	190	1.7	40	- 40	+ 20	+ 25	550	0.600 (15.24)	1C
52	120	+ 50, - 15	19	135	190	1.7	40	- 40	+ 20	+ 25	550	0.600 (15.24)	1C
53	220	± 20	21	145	210	1.8	30	- 60	+ 20	+ 25	694	1.100 (27.94)	1C
54	220	+ 50, - 15	21	145	210	1.8	30	- 60	+ 20	+ 25	694	1.100 (27.94)	1C
55	450	± 20	29	195	290	1.7	35	- 60	+ 20	+ 25	694	1.100 (27.94)	1C
56	450	+ 50, - 15	29	195	290	1.7	35	- 60	+ 20	+ 25	694	1.100 (27.94)	1C
180 V _{DC} AT + 85 °C RATED; 207 V _{DC} AT + 85 °C SURGE													
57	42	± 20	17	120	170	6	75	- 40	+ 20	+ 25	363	0.976 (24.79)	1C
58	42	+ 50, - 15	17	120	170	6	75	- 40	+ 20	+ 25	363	0.976 (24.79)	1C
59	60	± 20	19	135	190	3.4	60	- 40	+ 20	+ 25	363	0.976 (24.79)	1C
60	60	+ 50, - 15	19	135	190	3.4	60	- 40	+ 20	+ 25	363	0.976 (24.79)	1C
61	110	± 20	21	145	210	3.5	60	- 60	+ 20	+ 25	631	1.938 (49.23)	1C
62	110	+ 50, - 15	21	145	210	3.5	60	- 60	+ 20	+ 25	631	1.938 (49.23)	1C
63	230	± 20	29	200	290	3.5	50	- 60	+ 20	+ 25	631	1.938 (49.23)	1C
64	230	+ 50, - 15	29	200	290	3.5	50	- 60	+ 20	+ 25	631	1.938 (49.23)	1C
270 V _{DC} AT + 85 °C RATED; 310 V _{DC} AT + 85 °C SURGE													
65	28	± 20	19	120	190	9	80	- 40	+ 20	+ 25	339	1.350 (34.29)	1C
66	28	+ 50, - 15	19	120	190	9	80	- 40	+ 20	+ 25	339	1.350 (34.29)	1C
67	40	± 20	19	135	190	8.8	100	- 40	+ 20	+ 25	339	1.350 (34.29)	1C
68	40	+ 50, - 15	19	135	190	8.8	100	- 40	+ 20	+ 25	339	1.350 (34.29)	1C
69	75	± 20	21	145	210	5.2	90	- 60	+ 20	+ 25	608	2.812 (71.42)	1C
70	75	+ 50, - 15	21	145	210	5.2	90	- 60	+ 20	+ 25	608	2.812 (71.42)	1C
71	150	± 20	28	195	280	5.4	75	- 60	+ 20	+ 25	608	2.812 (71.42)	1C
72	150	+ 50, - 15	28	195	280	5.4	75	- 60	+ 20	+ 25	608	2.812 (71.42)	1C
360 V _{DC} AT + 85 °C RATED; 414 V _{DC} AT + 85 °C SURGE													
73	22	± 20	18	125	180	11.4	100	- 40	+ 20	+ 25	323	1.705 (43.31)	1C
74	22	+ 50, - 15	18	125	180	11.6	100	- 40	+ 20	+ 25	323	1.705 (43.31)	1C
75	30	± 20	19	135	190	11.7	120	- 40	+ 20	+ 25	323	1.705 (43.31)	1C
76	30	+ 50, - 15	19	135	190	11.7	120	- 40	+ 20	+ 25	323	1.705 (43.31)	1C
450 V _{DC} AT + 85 °C RATED; 518 V _{DC} AT + 85 °C SURGE													
77	17	± 20	18	125	180	15	130	- 40	+ 20	+ 25	315	2.080 (52.83)	1C
78	17	+ 50, - 15	18	125	180	15	130	- 40	+ 20	+ 25	315	2.080 (52.83)	1C
79	25	± 20	19	135	190	15	150	- 40	+ 20	+ 25	315	2.080 (52.83)	1C
80	25	+ 50, - 15	19	135	190	15	150	- 40	+ 20	+ 25	315	2.080 (52.83)	1C
540 V _{DC} AT + 85 °C RATED; 621 V _{DC} AT + 85 °C SURGE													
81	14	± 20	17	120	170	18	160	- 40	+ 20	+ 25	309	2.435 (61.85)	1C
82	14	+ 50, - 15	17	120	170	18	160	- 40	+ 20	+ 25	309	2.435 (61.85)	1C
83	20	± 20	19	135	190	18	170	- 40	+ 20	+ 25	309	2.435 (61.85)	1C
84	20	+ 50, - 15	19	135	190	18	170	- 40	+ 20	+ 25	309	2.435 (61.85)	1C
630 V _{DC} AT + 85 °C RATED; 724 V _{DC} AT + 85 °C SURGE													
85	12	± 20	17	120	170	16	180	- 40	+ 20	+ 25	306	2.810 (71.37)	1C
86	12	+ 50, - 15	17	120	170	16	180	- 40	+ 20	+ 25	306	2.810 (71.37)	1C
87	18	± 20	19	135	190	16	200	- 40	+ 20	+ 25	306	2.810 (71.37)	1C
88	18	+ 50, - 15	19	135	190	16	200	- 40	+ 20	+ 25	306	2.810 (71.37)	1C

FIGURES

FIGURE 1A

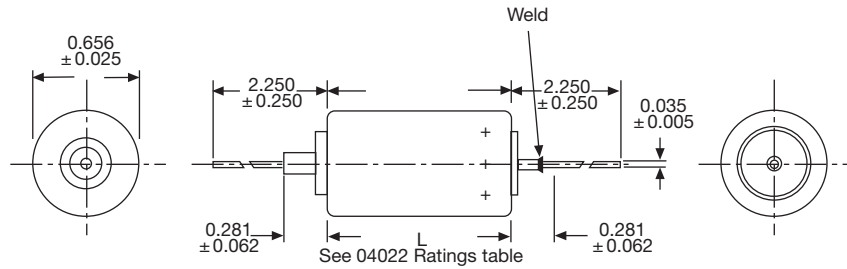

CASE CIRCUIT DIAGRAM

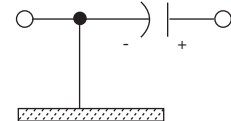
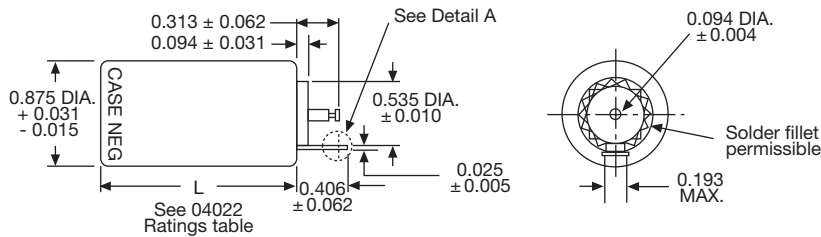

FIGURE 1B



**DETAIL A
SOLDER LUG
TERMINAL**

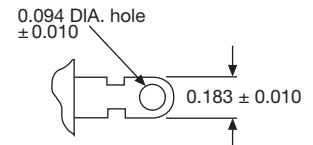
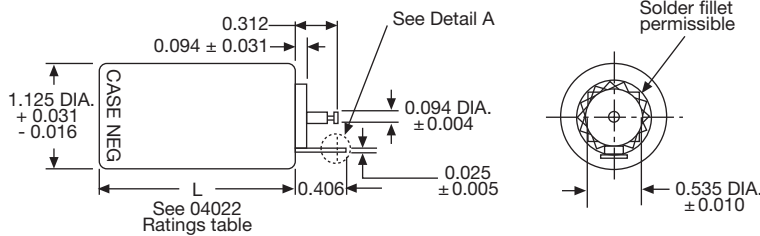

FIGURE 1C





Disclaimer

ALL PRODUCT, PRODUCT SPECIFICATIONS AND DATA ARE SUBJECT TO CHANGE WITHOUT NOTICE TO IMPROVE RELIABILITY, FUNCTION OR DESIGN OR OTHERWISE.

Vishay Intertechnology, Inc., its affiliates, agents, and employees, and all persons acting on its or their behalf (collectively, "Vishay"), disclaim any and all liability for any errors, inaccuracies or incompleteness contained in any datasheet or in any other disclosure relating to any product.

Vishay makes no warranty, representation or guarantee regarding the suitability of the products for any particular purpose or the continuing production of any product. To the maximum extent permitted by applicable law, Vishay disclaims (i) any and all liability arising out of the application or use of any product, (ii) any and all liability, including without limitation special, consequential or incidental damages, and (iii) any and all implied warranties, including warranties of fitness for particular purpose, non-infringement and merchantability.

Statements regarding the suitability of products for certain types of applications are based on Vishay's knowledge of typical requirements that are often placed on Vishay products in generic applications. Such statements are not binding statements about the suitability of products for a particular application. It is the customer's responsibility to validate that a particular product with the properties described in the product specification is suitable for use in a particular application. Parameters provided in datasheets and/or specifications may vary in different applications and performance may vary over time. All operating parameters, including typical parameters, must be validated for each customer application by the customer's technical experts. Product specifications do not expand or otherwise modify Vishay's terms and conditions of purchase, including but not limited to the warranty expressed therein.

Except as expressly indicated in writing, Vishay products are not designed for use in medical, life-saving, or life-sustaining applications or for any other application in which the failure of the Vishay product could result in personal injury or death. Customers using or selling Vishay products not expressly indicated for use in such applications do so at their own risk and agree to fully indemnify and hold Vishay and its distributors harmless from and against any and all claims, liabilities, expenses and damages arising or resulting in connection with such use or sale, including attorneys fees, even if such claim alleges that Vishay or its distributor was negligent regarding the design or manufacture of the part. Please contact authorized Vishay personnel to obtain written terms and conditions regarding products designed for such applications.

No license, express or implied, by estoppel or otherwise, to any intellectual property rights is granted by this document or by any conduct of Vishay. Product names and markings noted herein may be trademarks of their respective owners.

Material Category Policy

Vishay Intertechnology, Inc. hereby certifies that all its products that are identified as RoHS-Compliant fulfill the definitions and restrictions defined under Directive 2011/65/EU of The European Parliament and of the Council of June 8, 2011 on the restriction of the use of certain hazardous substances in electrical and electronic equipment (EEE) - recast, unless otherwise specified as non-compliant.

Please note that some Vishay documentation may still make reference to RoHS Directive 2002/95/EC. We confirm that all the products identified as being compliant to Directive 2002/95/EC conform to Directive 2011/65/EU.