



VISHAY INTERTECHNOLOGY, INC.

RESISTIVE PRODUCTS

ULTRA HIGH-PRECISION CURRENT SENSING

Bulk Metal[®] Foil Resistors

CAPABILITIES

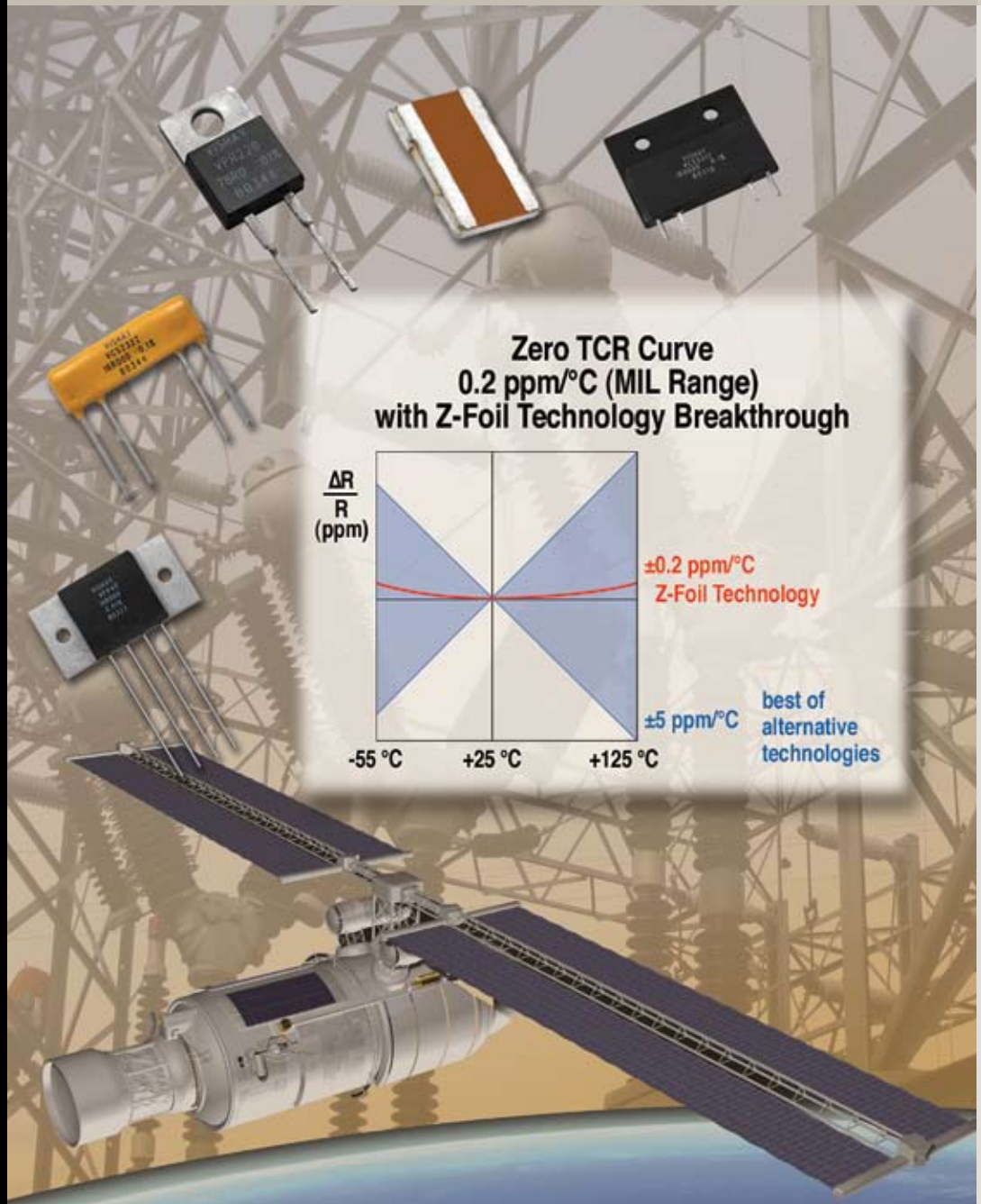

**Zero TCR Curve
0.2 ppm/°C (MIL Range)
with Z-Foil Technology Breakthrough**

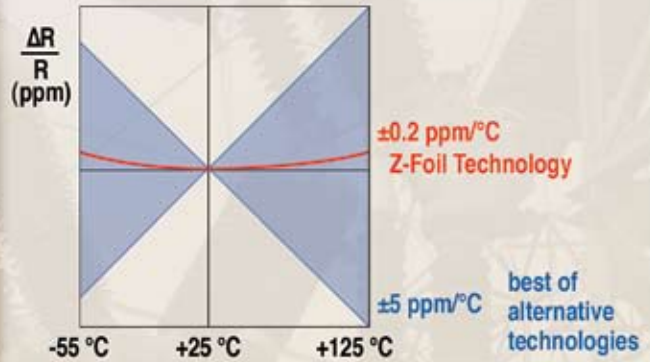



Ultra High-Precision Current Sensing

Current Sensing – General

High precision resistors used for current sensing are usually low ohmic value devices suitable for four terminal connection.

Two terminals, called "current terminals", are connected to let the electrical current pass through the resistor and voltage drop V_s is measured on other two, called "sense" or "voltage drop" terminals. According to Ohm's law, the sensed voltage drop V_s divided by the known resistance R_s gives the sensed current I_s .

The accuracy of measurement depends on the stability of ohmic resistance R_s between the nodes – points of connection of the sense leads.

This arrangement, called "Kelvin connection", reduces, especially for low ohmic resistance values, a measurement error due to the resistance of the lead wires and the solder joints as the sensing is performed inside the resistor, in or close to the active resistive foil.

The foil technology is best suited for manufacture of low values due to the superior resistor's stability compared to thick film or thin film technologies.

Temperature Coefficients – TCR and PCR

The best known parameter used to specify resistor's stability is the TCR – Temperature Coefficient of Resistance – which expresses, in parts per million per degree centigrade (ppm/°C), the resistance change $\Delta R/R$ due to the change in ambient temperature, over a specified temperature range.

The change of resistance with temperature is caused by a change of the resistivity of foil's material and by thermal stresses when foil and substrate expand. In the case of a thin NiCr foil cemented to a ceramic substrate, the foil cannot expand freely – the ceramic forces the foil to expand or contract with it.

Second, less known parameter is the power coefficient – PCR, or "Power Coefficient of Resistance." It quantifies the effect of the self-heating due to the Joule effect – the RI^2 losses.

When high precision is not required, the ambient temperature rise and the temperature rise due to self-heating can be combined and multiplied by TCR in order to assess the $\Delta R/R$, but this approach can lead to an excessive error in high precision measurements.

These phenomena are reversible – when the ambient temperature and the dissipated power return to the original ones, so does the resistance value.

Other non-reversible phenomena are quantified in resistor datasheets in the form of tables of environmental tests – like long-term load life at a specified ambient temperature, high temperature exposure and others. Precision measurements usually permit avoidance of harsh environmental conditions while special cases must be handled individually.

Additional sources of measurement errors are electrical noise and thermoelectric effect. Noise is negligible in Bulk Metal® Foil resistors.

Thermoelectric effect (called Seebeck effect) occurs when two dissimilar metals, M_1 and M_2 , form two joints, M_1M_2 and M_2M_1 , which see different temperatures. The voltage created (called ThEMF) depends on the nature of metals and on temperature difference. For high precision, all leads should be made of the same metal and (equality of joint's temperature should be maintained) joints designed to minimize temperature differences between them.

The TCR is tested by recording each time the change of resistance ($\Delta R/R$, in ppm) after stabilizing the resistor at each of a few given temperatures.

But in performance of a current sensing device, the situation is different: the change of foil's temperature is caused not only by a change in ambient temperature but also by the self-heating. It causes a change in foil's resistivity in a similar way like the change in ambient temperature, but not necessarily a similar change in measured resistance. In other words, heating the foil for instance by 10 °C once by raising the room temperature and a second time by self-heating will result in different changes in resistance.

This difference is due to a difference in thermal stresses. When the ambient temperature rises, the foil and the substrate heat up at the same rate. But when the heat is generated in the foil, it flows through the cement to the substrate, giving rise to temperature gradients along the path of heat's flow. Therefore, the foil and substrate are now at different temperatures and, in case when substrate's (e.g. alumina) coefficient of thermal expansion is lower than foil's, the much thinner foil follows the dimensional changes of the substrate – it cannot expand as much as during external heating and a lower resistance value is measured.

There is a simple, but not always best way to reduce the effect of self-heating: derating – choosing resistors of power rating much higher than needed. This is a costly solution, especially because of the low TCR required.

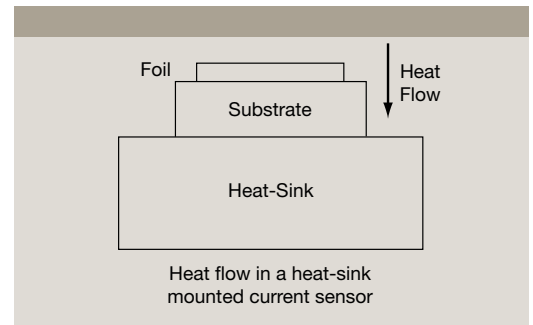
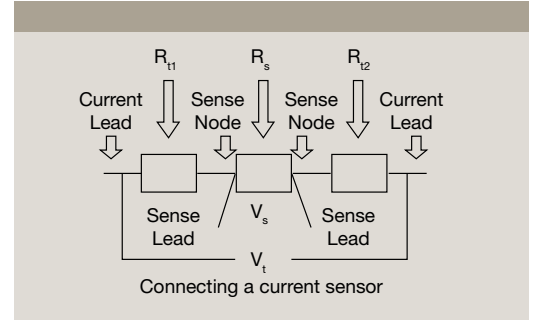

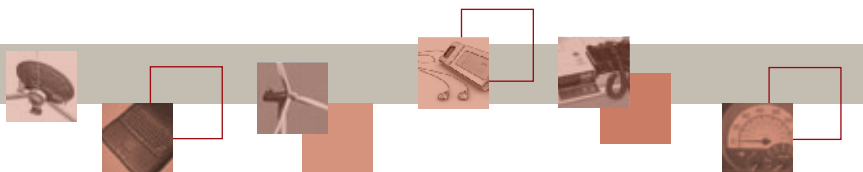

Vishay Solutions

Based on its expertise in Stress Analysis and Precision Resistors of extremely low TCR, Vishay developed several proprietary technologies⁽¹⁾ for production of high precision current sensing resistors⁽¹⁾.

The use of Z-Foil allows the achievement of very low TCR over wide temperature range. This is due to the inherent flatness of resistance versus temperature curve of resistors produced with Z-Foil. In case of current sensors, the relevant temperature range must encompass both changes – due to changing ambient temperature and due to self-heating.

Dealing efficiently with the PCR requires collaboration with the customer because it is influenced by customer's assembly method, anticipated current fluctuations and requirements of accuracy and speed of response.

The temperature difference between resistive foil and substrate can be evaluated from the RI^2 losses⁽²⁾ and the resistor's internal thermal resistance. But power rating is limited by foil's maximum temperature, which depends on total thermal resistance between the foil and the ambient, and this is influenced by assembly method and resistor's construction. Heat sink mounted, surface-mounted and through-hole molded devices will show different substrate's temperature when their foil self-heats to the same temperature. Heat sink mounting increases the power rating of a resistor, but sometimes at the expense of the PCR, which increases due to larger temperature difference, for a given power, between the foil and the substrate.

Power Ratings

A statement of power rating for a given resistor should be always evaluated in context with definition of service conditions. Sometimes more than one number is stated in the datasheet, and sometimes the service conditions stated are not relevant for a given customer's application. For instance, two different values of power rating are sometimes stated for two different ambient temperatures.

In case a power rating is given for an assembly method which is capable of maintaining the resistor's substrate at room temperature, a very high figure can be claimed for power rating, but such service condition is costly to achieve.

Vishay's datasheets for precision heat sink mounted resistors usually state two values of power rating – for free air cooling and for mounting on a heat sink as defined by the US Military Standards. Such a heat sink can dissipate heat only when the temperature of resistor's substrate is higher than the ambient temperature.

So a current sensor of the heat sink mounted style can be assigned three different power ratings (and, accordingly, three different PCR's) – for mounting in free air, on a standard heat sink and on a Peltier type electronic cooling device which keeps resistor's substrate at room temperature.

Therefore, optimal stability can be obtained only by evaluation of customer's application – mounting method and performance requirements – and choosing the most fitting technical solution among the various types of power sensing resistors available.

Conclusions

Vishay achieves a very high precision in current sensing by:

- Using Z-Foil for very low TCR (0.2 ppm/°C typical) over wide temperature ranges. Z-Foil also provides a PCR (Power Coefficient of Resistance) of 4 ppm/Watt typical.
- Applying proprietary methods of manufacturing precision 4-terminal resistors.
- Applying its expertise in stress analysis.

Examples of high precision power current sensing Z-Foil resistors:

Leaded: VHP4Z, VPR247Z, VFP4Z, VCS331Z, VCS332Z, VCS232Z, VPR220Z, VPR221Z

SMD: VCS2516Z

For more details about resistors styles, please visit Vishay's web site at: www.vishay.com/resistors-discrete/metal-foil/. For technical support, contact foil@vishay.com

References

F. Zandman et al. *Resistor Theory and Technology*. (2002) Scitech Publishing, Inc.

R. Goldstein and J. Szwarc. *Zero TCR Foil Resistor* – Vishay.

R. Goldstein and J. Szwarc. *New Foil Resistor with Very Low Power Coefficient* – Vishay.

⁽¹⁾ Patents concerning 4-terminal precision resistors were recently granted to Vishay.

⁽²⁾ For very low value (milliohm range) 4-terminal resistors, the self heating is due not only to the IR^2 losses (R_s – resistance between sense nodes), but to the total losses which include also the losses in R_{t1} and R_{t2} – the resistances of current terminations from the pad's solder joints to the sense nodes. These additional losses can be significant, especially for thin plated pads and when the sense nodes are situated in the resistive material. The total losses can be assessed by measuring V_t – the voltage drop at current terminals.



SEMICONDUCTORS:

Rectifiers • Small-Signal Diodes • Zener and Suppressor Diodes • MOSFETs
• RF Transistors • Optoelectronics • ICs

PASSIVE COMPONENTS:

Resistive Products • Magnetics • Capacitors • Strain Gages and Strain Gage Instruments
• PhotoStress[®] Instruments • Transducers

One of the World's Largest
Manufacturers
of Discrete Semiconductors and Passive Components

WORLDWIDE SALES CONTACTS

THE AMERICAS

UNITED STATES

VISHAY INTERTECHNOLOGY, INC.
63 LINCOLN HIGHWAY
MALVERN, PA 19355
UNITED STATES
PH: +1-610-407-4800
FAX: +1-610-640-9081

ASIA

SINGAPORE

VISHAY INTERTECHNOLOGY
ASIA PTE LTD.
25 TAMPINES STREET 92
KEPPEL BUILDING #02-00
SINGAPORE 528877
PH: +65-6788-6668
FAX: +65-6788-0988

P.R.C.

VISHAY INTERTECHNOLOGY
ASIA PTE LTD.
(SHANGHAI REPRESENTATIVE OFFICE)
ROOM D, 15F, SUN TONG INFOPORT PLAZA
55 HUAI HAI WEST ROAD
200030 SHANGHAI
P.R.C.
PH: +86-21-6283-1036
FAX: +86-21-6283-1039

JAPAN

VISHAY JAPAN CO., LTD.
SHIBUYA 3-CHOME SQUARE BUILDING 3F
3-5-16 SHIBUYA
SHIBUYA-KU
TOKYO 150-0002
JAPAN
PH: +81-3-5464-6411
FAX: +81-3-5464-6433

EUROPE

GERMANY

VISHAY EUROPE SALES GMBH
GEHEIMRAT-ROSENTHAL-STR. 100
95100 SELB
GERMANY
PH: +49-9287-71-0
FAX: +49-9287-70435

FRANCE

VISHAY S.A.
199, BLVD DE LA MADELEINE
06003 NICE, CEDEX 1
FRANCE
PH: +33-4-9337-2920
FAX: +33-4-9337-2997

NETHERLANDS

VISHAY BCCOMPONENTS B.V.
HURKESTRAAT 31
P.O. BOX 8766
5652 AH EINDHOVEN
NETHERLANDS
PH: +31-40-2590-700
FAX: +31-40-2590-777