

# 9 mm Multi-Ganged Potentiometer

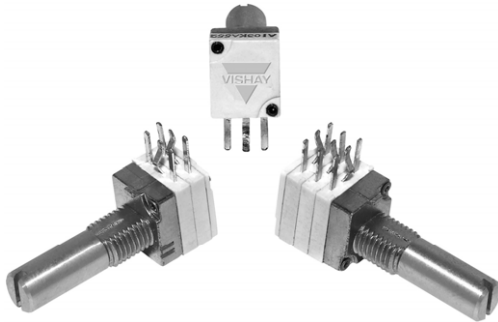

## FEATURES

- Conductive plastic element
- Ultra compact (extra miniature module size)
- Multiple assemblies (up to seven modules)
- Shaft and panel sealed option
- Center mechanical detent fully integrated in option
- Center tap option
- Custom designs available on request
- Test according to CECC 41000 or IEC 60393-1
- Material categorization: for definitions of compliance please see [www.vishay.com/doc?99912](http://www.vishay.com/doc?99912)

**RoHS**  
COMPLIANT

## QUICK REFERENCE DATA

Multiple module	Up to 7 modules
Switch module	n/a
Detent module	Yes
Special electrical laws	A: linear, L: logarithmic, F: reverse logarithmic and others see specification
Sealing level	IP 64
Lifespan	25K cycles

## DIMENSIONS in millimeters (inches) ± 0.5 mm (± 0.02")

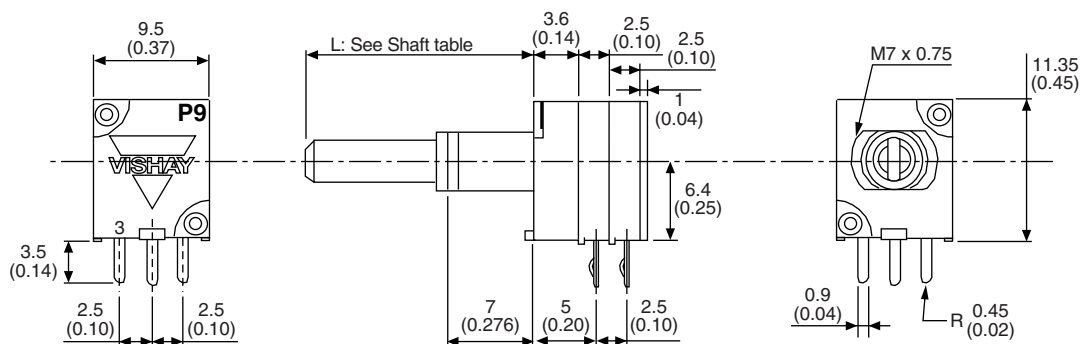

### Vertical Mounting

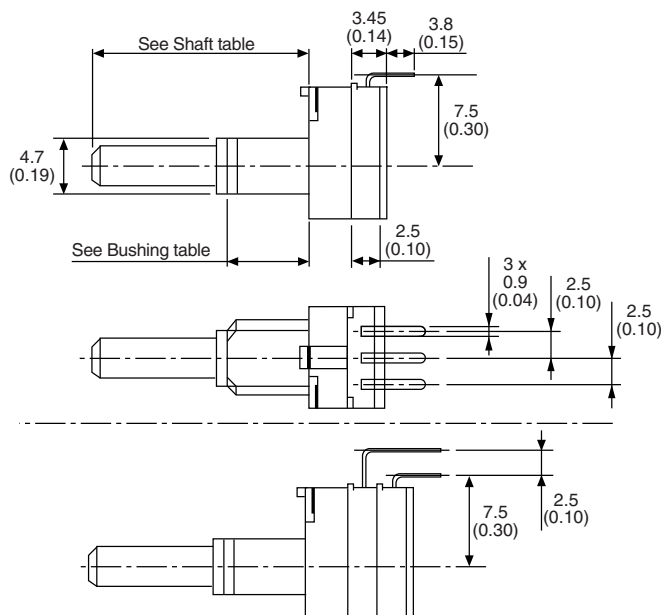

### Center Tap

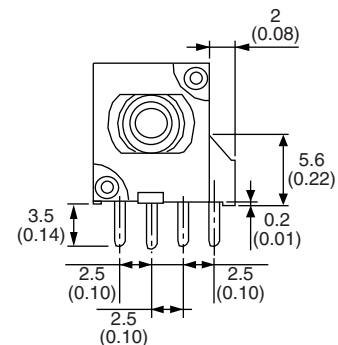

### Center Tap and Vertical Mounting

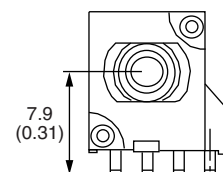

**GENERAL SPECIFICATIONS**

ELECTRICAL SPECIFICATIONS		
Resistive element	Conductive plastic	
Electrical travel	270° ± 10°	
Power rating chart		
Circuit diagram		
Taper		
Resistance range	Linear taper Non-linear taper	1 kΩ to 1 MΩ 2.2 kΩ to 500 kΩ
Tolerance	Standard On request	20 % 10 %
Power rating at 70 °C	Linear Taper Non-Linear Taper Multiple assemblies linear taper Multiple assemblies non-linear taper	0.1 W 0.05 W 0.05 W per module 0.025 W per module
Temperature coefficient (typical)	± 500 ppm	
Limiting element voltage	10 V <sub>DC</sub> 50 V <sub>AC</sub>	
End resistance (typical)	3 Ω	
Contact resistance variation	Linear law (typical)	2 % of nominal resistance
Independent linearity	Linear law (typical)	± 5 %
Insulation resistance	100 MΩ at 250 V <sub>DC</sub>	
Dielectric strength	300 V <sub>AC</sub> during 1 min	
Attenuation (typical)	90 dB max./0.05 dB min.	



MECHANICAL SPECIFICATIONS	
Mechanical travel	25 000 cycles min.
Mechanical travel	300° ± 5
Operating torque	0.2 Ncm to 1.5 Ncm (0.3 oz.-inch to 1.8 oz.-inch)
End stop torque	50 Ncm max. (4.4 lb-inch max.)
Shaft push/pull force	7 DaNcm max. (15.7 lbf max.)
Weight (one module)	6.25 g (without nut and washer) (0.22 oz.)

**Note**

- Nothing stated herein shall be construed as a guarantee of quality or durability

ENVIRONMENTAL SPECIFICATIONS	
Temperature range	-55 °C to +100 °C
Climatic category	55/100/21
Sealing	IP 64

MARKING
<ul style="list-style-type: none"> <li>Code for tolerance</li> <li>Code for ohmic value</li> <li>Taper</li> <li>Code for date code</li> </ul>

PACKAGING
<ul style="list-style-type: none"> <li>Box of 25 pieces</li> <li>Box of 100 pieces</li> </ul>

PERFORMANCE				
TESTS	CONDITIONS	TYPICAL VALUE AND DRIFTS		
		$\Delta R_T/R_T$ (%)	$\Delta R_{1-2}/R_{1-2}$ (%)	OTHER
Electrical endurance	1000 h at rated power 90'/30' - ambient temp. 70 °C	± 5 %	± 10 %	Contact resistance variation < 5 % R <sub>n</sub>
Damp heat, steady state	21 days at 40 °C ± 2 °C and 90 % to 95 % relative humidity	± 5 %	-	Insulation resistance > 10 MΩ
Change of temperature	Ambient temperature -55 °C to +100 °C 5 cycles	± 0.5 %	-	-
Mechanical endurance	25 000 cycles at rated power 90 % of electrical travel 16 cycles per minute Temperature: 20 °C	± 6 %	-	Contact resistance variation ± 12 %
Shock	50 g's, 11 ms 3 shocks - 3 directions	± 0.2 %	± 0.5 %	-
Vibration	10 Hz to 55 Hz 0.75 mm or 10 g's 6 h	± 0.2 %	-	$\Delta V_{1-2}/V_{1-3}$ ± 0.5 %

ORDERING INFORMATION (Part Number)																	
P	9	A	1	R	1	0	0	F	I	R	X	1	1	0	3	M	A
MODEL	NUMBER OF MODULES	BUSHING	LOCATING PEG	PANEL SEALED	DETENT OPTION	SHAFT	PIN STYLE		RESISTANCE CODE/TOLERANCE CODE/TAPER								
P9A	1 to 7	R = M7 x 0.75 mm to 7 mm X = M7 x 0.75 mm to 5 mm															

BUSHING		
<b>X: Bushing</b>	<b>R: Bushing</b>	<ul style="list-style-type: none"> <li>Nut tightening torque M7 bushing 120 Ncm max. (10.6 lb-inch max.)</li> <li>Nut and washer are delivered in standard packaging</li> </ul>
<p>M7 x 0.75</p> <p>5 (0.20)</p>	<p>M7 x 0.75</p> <p>7 (0.28)</p>	<p>10</p> <p>M7 x 0.75</p> <p>2</p> <p>0.7</p>

ORDERING INFORMATION (Part Number)																	
P	9	A	1	R	1	0	0	F	I	R	X	1	1	0	3	M	A
MODEL	NUMBER OF MODULES	BUSHING	LOCATING PEG	PANEL SEALED	DETENT OPTION	SHAFT	PIN STYLE				RESISTANCE CODE/TOLERANCE CODE/TAPER						
			0 = without 1 = with	0 = without P = with	0 = without M = center detent	See code below											

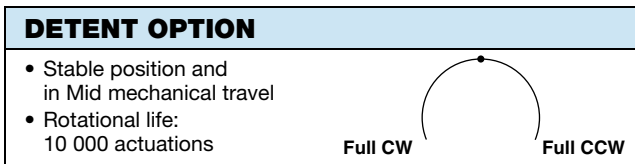
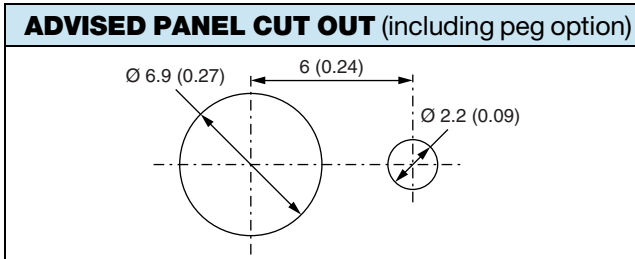
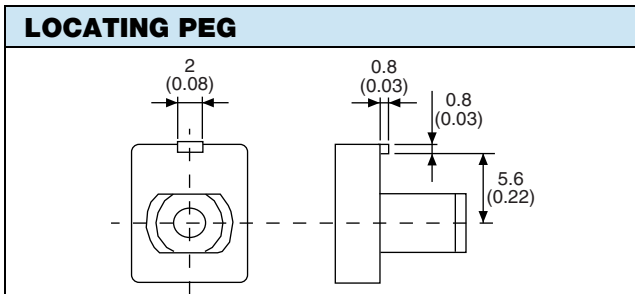

### PANEL SEALED

- Only for R and X bushing without locating peg
- Front mounting surface with panel sealed option is: 6.2 mm ± 0.5 mm length for R bushing and 4.2 mm ± 0.5 mm length for X bushing
- The ring is delivered with nut and washer
- The seal should be placed between panel and body. Sealing is obtained by tightening the seal against the panel when mounting the potentiometer. Tightening torque 50 Ncm up to 100 Ncm
- Advised panel hole dimensions:

### SHAFT DIAMETER - FMS - STYLE

L (mm)	15				20			25			30		
Style	Round	Slotted	Flat	Knurled	Round	Slotted	Flat	Round	Slotted	Flat	Round	Slotted	Flat
Ø 3.5	DFR	DFS	DFF	-	DIR	DIS	DIF	DLR	DLS	DLF	DMR	DMS	DMF
Ø 6	FFR	FFS	FFF	FGK <sup>(1)</sup>	FIR	FIS	FIF	FLR	FLS	FLF	FMR	FMS	FMF

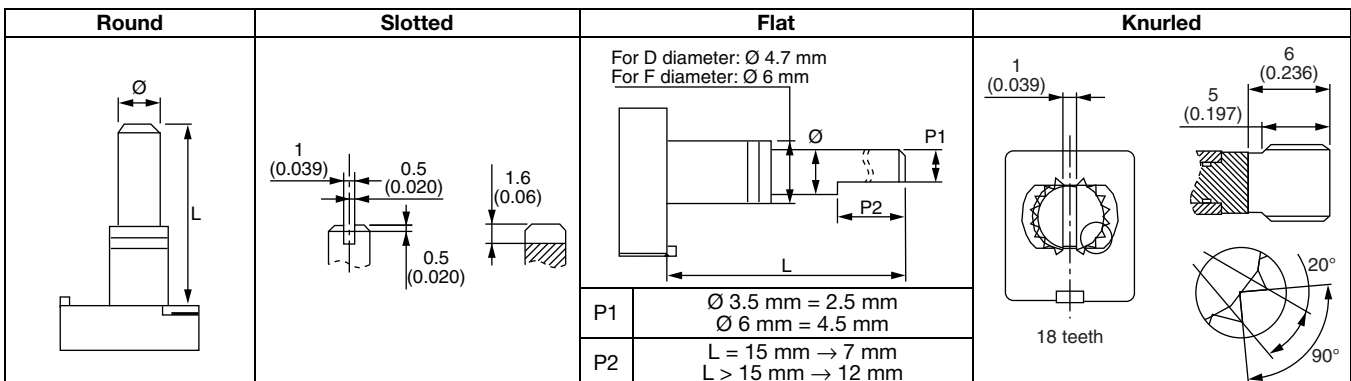
**Note**
<sup>(1)</sup> For X bushing (16 mm)

ORDERING INFORMATION (Part Number)																	
P	9	A	1	R	1	0	0	F	I	R	X	1	1	0	3	M	A
MODEL	NUMBER OF MODULES	BUSHING	LOCATING PEG	PANEL SEALED	DETENT OPTION	SHAFT	PIN STYLE				RESISTANCE CODE/TOLERANCE CODE/TAPER						
							<b>See Pin table</b> First digit: pin type X, J, S, Z, P, L W or N Second digit: pin configuration 1, 2, 3, 4 or N										

PIN STYLE - HORIZONTAL MOUNTING			
PIN TYPE			
X	PC mount		
J	PC mount center tap		
S	Soldering style		
Z	Center tap soldering style		
L	Long pin		
P	Center tap with long pin		
NN	If different types of pin style in the same potentiometer		
PIN CONFIGURATION			
1	2	3	
2.5 mm between gang	2.5 mm - 5 mm - 2.5 mm between gang	5 mm between gang	

ORDERING INFORMATION (Part Number)																	
P	9	A	1	R	1	0	0	F	I	R	X	1	1	0	3	M	A
MODEL	NUMBER OF MODULES	BUSHING	LOCATING PEG	PANEL SEALED	DETENT OPTION	SHAFT	PIN STYLE					RESISTANCE CODE/TOLERANCE CODE/TAPER					
							<b>See Pin table</b> First digit: pin type X, J, S, Z, P, L W or N Second digit: pin configuration 1, 2, 3, 4 or N										

PIN STYLE - VERTICAL MOUNTING			
<b>W1</b>	Single gang vertical mounting		
<b>W2</b>	Dual gang vertical mounting		
<b>W3</b>	Single gang with center tap vertical mounting		
<b>W4</b>	Dual gang with center tap vertical mounting		



ORDERING INFORMATION (part number)																	
P	9	A	1	R	1	0	0	F	I	R	X	1	1	0	3	M	A
MODEL	NUMBER OF MODULES	BUSHING	LOCATING PEG	PANEL SEALED	DETENT OPTION	SHAFT	PIN STYLE				RESISTANCE CODE/TOLERANCE CODE/TAPER						
											Resistance code: 102 = 1 kΩ to 105 = 1 MΩ Tolerance code: standard: M = ± 20 % on request: K = ± 10 % taper: A, L, W, F, S, R or special code given by Vishay						

SPECIAL CODES GIVEN BY VISHAY
<ul style="list-style-type: none"> <li>• Custom shaft</li> <li>• Design on request</li> <li>• Specific linearity</li> <li>• Specific interlinearity</li> <li>• Specific variation law</li> </ul>

PART NUMBER DESCRIPTION (for information only)														
P9A	1	R	1	0	0	FI	R	X1	10K	20 %	A			e3
MODEL	MODULES	BUSHING	LOCATING PEG	SEALING OPTIONS	DETENT OPTIONS	SHAFT	SHAFT	LEADS	VALUE	TOL.	TAPER	SPECIAL	SPECIAL	LEAD (Pb)-FREE

RELATED DOCUMENTS	
<b>APPLICATION NOTES</b>	
Potentiometers and Trimmers	<a href="http://www.vishay.com/doc?51001">www.vishay.com/doc?51001</a>
Guidelines for Vishay Sfernice Resistive and Inductive Components	<a href="http://www.vishay.com/doc?52029">www.vishay.com/doc?52029</a>





## **Disclaimer**

ALL PRODUCT, PRODUCT SPECIFICATIONS AND DATA ARE SUBJECT TO CHANGE WITHOUT NOTICE TO IMPROVE RELIABILITY, FUNCTION OR DESIGN OR OTHERWISE.

Vishay Intertechnology, Inc., its affiliates, agents, and employees, and all persons acting on its or their behalf (collectively, "Vishay"), disclaim any and all liability for any errors, inaccuracies or incompleteness contained in any datasheet or in any other disclosure relating to any product.

Vishay makes no warranty, representation or guarantee regarding the suitability of the products for any particular purpose or the continuing production of any product. To the maximum extent permitted by applicable law, Vishay disclaims (i) any and all liability arising out of the application or use of any product, (ii) any and all liability, including without limitation special, consequential or incidental damages, and (iii) any and all implied warranties, including warranties of fitness for particular purpose, non-infringement and merchantability.

Statements regarding the suitability of products for certain types of applications are based on Vishay's knowledge of typical requirements that are often placed on Vishay products in generic applications. Such statements are not binding statements about the suitability of products for a particular application. It is the customer's responsibility to validate that a particular product with the properties described in the product specification is suitable for use in a particular application. Parameters provided in datasheets and / or specifications may vary in different applications and performance may vary over time. All operating parameters, including typical parameters, must be validated for each customer application by the customer's technical experts. Product specifications do not expand or otherwise modify Vishay's terms and conditions of purchase, including but not limited to the warranty expressed therein.

Except as expressly indicated in writing, Vishay products are not designed for use in medical, life-saving, or life-sustaining applications or for any other application in which the failure of the Vishay product could result in personal injury or death. Customers using or selling Vishay products not expressly indicated for use in such applications do so at their own risk. Please contact authorized Vishay personnel to obtain written terms and conditions regarding products designed for such applications.

No license, express or implied, by estoppel or otherwise, to any intellectual property rights is granted by this document or by any conduct of Vishay. Product names and markings noted herein may be trademarks of their respective owners.