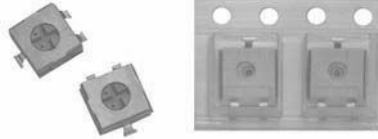

# Cermet Trimmers, Surface Mount, 4.0 mm Square, Single Turn, Industrial Grade

**FEATURES**

- 0.25 W at 70 °C
- Fully sealed to withstand board washing
- Compatible with popular vacuum pick-and-place equipment
- J-hook and gull-wing configurations
- Compliant to RoHS Directive 2002/95/EC

**RoHS**  
COMPLIANT

DIMENSIONS in millimeters (inches) ± 0.25 mm (± 0.010")		
<b>TS4YJ</b> 		<p>Recommended PCB footprint</p>
<b>TS4YL</b> 		<p>Recommended PCB footprint</p>

ELECTRICAL SPECIFICATIONS	
<b>Resistive Range</b>	10 Ω to 2 MΩ (see Standard Resistance table)
<b>Tolerance</b>	± 20 % standard
<b>End Resistance</b>	1 % or 2 Ω maximum, whichever is greater
<b>Temperature Coefficient</b>	± 100 ppm/°C
<b>Power Rating</b>	(300 V maximum) 0.25 W at + 70 °C, 0 W at + 125 °C
<b>Circuit Diagram</b>	
<b>Contact Resistance Variation (CRV)</b>	1 % or 3 Ω
<b>Resolution</b>	Infinite
<b>Insulation Resistance (500 V<sub>DC</sub>)</b>	100 MΩ minimum
<b>Dielectric Strength (RMS)</b>	Sea level 500 V <sub>AC</sub> (1 minute)
<b>Adjustment Angle</b>	210° nominal

MECHANICAL SPECIFICATIONS	
Mechanical Angle	240° nominal
Operating Torque (Typical)	1.8 Ncm
End Stop Torque (Typical)	3.0 Ncm
Weight	Approximately 0.01 oz.
Wiper	Positioned at approx. 50 %

ENVIRONMENTAL SPECIFICATIONS	
Temperature Range	- 55 °C to + 125 °C
MSL Level	1

PERFORMANCES				
TESTS	CONDITIONS	TYPICAL VALUES AND DRIFTS		
		$\Delta R_T/R_T$ (%)	$\Delta V_{1-2}/V_{1-3}$ (%)	OTHER
Vibration	20 g's	± 1 %	± 1 %	-
Shock	100 g's	± 1 %	± 1 %	-
Electrical Endurance	At 70 °C rated power 1000 h	± 3 %	-	-
Mechanical Endurance	100 cycles	± 3 %	-	-
Change of Temperature	5 cycles	± 2 %	± 1 %	-
Humidity	90 % to 98 % relative humidity 10 cycles, 240 h	± 2 %	-	Insulation resistance:10 MΩ

SOLDERING RECOMMENDATIONS
Recommended reflow profile 2, see Application Note <a href="http://www.vishay.com/doc?52029">www.vishay.com/doc?52029</a>

TWO DIGIT DATE CODE					
YEAR					
1990	A	2000	M	2010	A
1991	B	2001	N	2011	B
1992	C	2002	P	2012	C
1993	D	2003	R	2013	D
1994	E	2004	S	2014	E
1995	F	2005	T	2015	F
1996	H	2006	U	2016	H
1997	J	2007	V	2017	J
1998	K	2008	W	2018	K
1999	L	2009	X	2019	L
MONTH					
January	1	July	7		
February	2	August	8		
March	3	September	9		
April	4	October	O		
May	5	November	N		
June	6	December	D		

STANDARD RESISTANCE ELEMENT DATA	
RESISTANCE Ω	RESISTANCE CODE
10	100
20	200
50	500
100	101
200	201
500	501
1K	102
2K	202
5K	502
10K	103
20K	203
50K	503
100K	104
200K	204
500K	504
1M	105
2M	205

**Note**  
 • Special resistance available

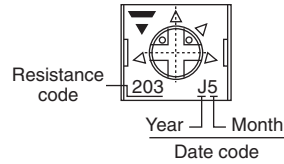
**PART MARKING**

- Manufacturers code
- Resistance code
- Date code

**PACKAGING** in millimeters (inches)

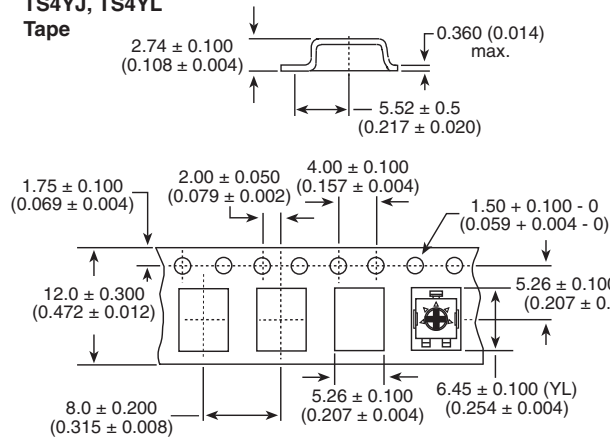
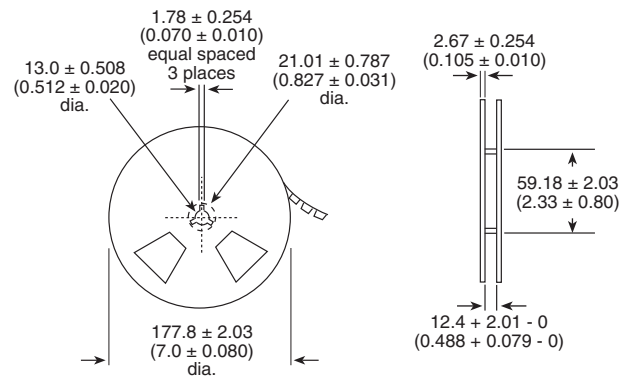
**TS4YJ, TS4YL**  
**Tape**

**TS4YJ, TS4YL**  
**Reel**

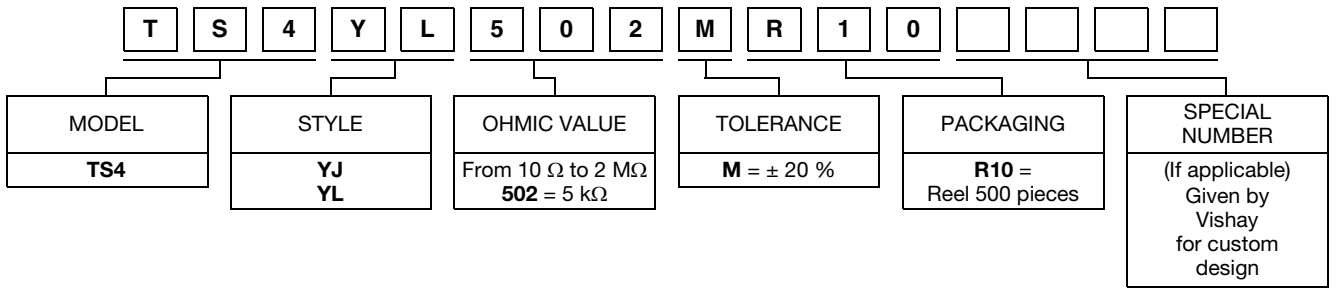
500 pieces per 7" reel standard. Meets EIA Specifications 481.

**ORDERING INFORMATION** (Part Number)

**DESCRIPTION** (for information only)

<b>TS4</b>	<b>YL</b>	<b>5K</b>	<b>20 %</b>		<b>TR</b>	<b>e3</b>
MODEL	STYLE	VALUE	TOLERANCE	SPECIAL	PACKAGING	LEAD FINISH



## Disclaimer

ALL PRODUCT, PRODUCT SPECIFICATIONS AND DATA ARE SUBJECT TO CHANGE WITHOUT NOTICE TO IMPROVE RELIABILITY, FUNCTION OR DESIGN OR OTHERWISE.

Vishay Intertechnology, Inc., its affiliates, agents, and employees, and all persons acting on its or their behalf (collectively, "Vishay"), disclaim any and all liability for any errors, inaccuracies or incompleteness contained in any datasheet or in any other disclosure relating to any product.

Vishay makes no warranty, representation or guarantee regarding the suitability of the products for any particular purpose or the continuing production of any product. To the maximum extent permitted by applicable law, Vishay disclaims (i) any and all liability arising out of the application or use of any product, (ii) any and all liability, including without limitation special, consequential or incidental damages, and (iii) any and all implied warranties, including warranties of fitness for particular purpose, non-infringement and merchantability.

Statements regarding the suitability of products for certain types of applications are based on Vishay's knowledge of typical requirements that are often placed on Vishay products in generic applications. Such statements are not binding statements about the suitability of products for a particular application. It is the customer's responsibility to validate that a particular product with the properties described in the product specification is suitable for use in a particular application. Parameters provided in datasheets and/or specifications may vary in different applications and performance may vary over time. All operating parameters, including typical parameters, must be validated for each customer application by the customer's technical experts. Product specifications do not expand or otherwise modify Vishay's terms and conditions of purchase, including but not limited to the warranty expressed therein.

Except as expressly indicated in writing, Vishay products are not designed for use in medical, life-saving, or life-sustaining applications or for any other application in which the failure of the Vishay product could result in personal injury or death. Customers using or selling Vishay products not expressly indicated for use in such applications do so at their own risk and agree to fully indemnify and hold Vishay and its distributors harmless from and against any and all claims, liabilities, expenses and damages arising or resulting in connection with such use or sale, including attorneys fees, even if such claim alleges that Vishay or its distributor was negligent regarding the design or manufacture of the part. Please contact authorized Vishay personnel to obtain written terms and conditions regarding products designed for such applications.

No license, express or implied, by estoppel or otherwise, to any intellectual property rights is granted by this document or by any conduct of Vishay. Product names and markings noted herein may be trademarks of their respective owners.