

Surface Mounted Power Resistor Thick Film Technology

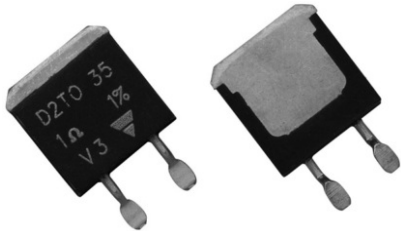

FEATURES

- 35 W at 25 °C case temperature
- Surface mounted resistor - TO-263 (D²PAK) style package
- Wide resistance range from 0.01 Ω to 550 kΩ
- Non inductive
- RoHS compliant
- Resistor isolated from metal tab
- Solder reflow secure at 270 °C/10 s



DIMENSIONS in millimeters

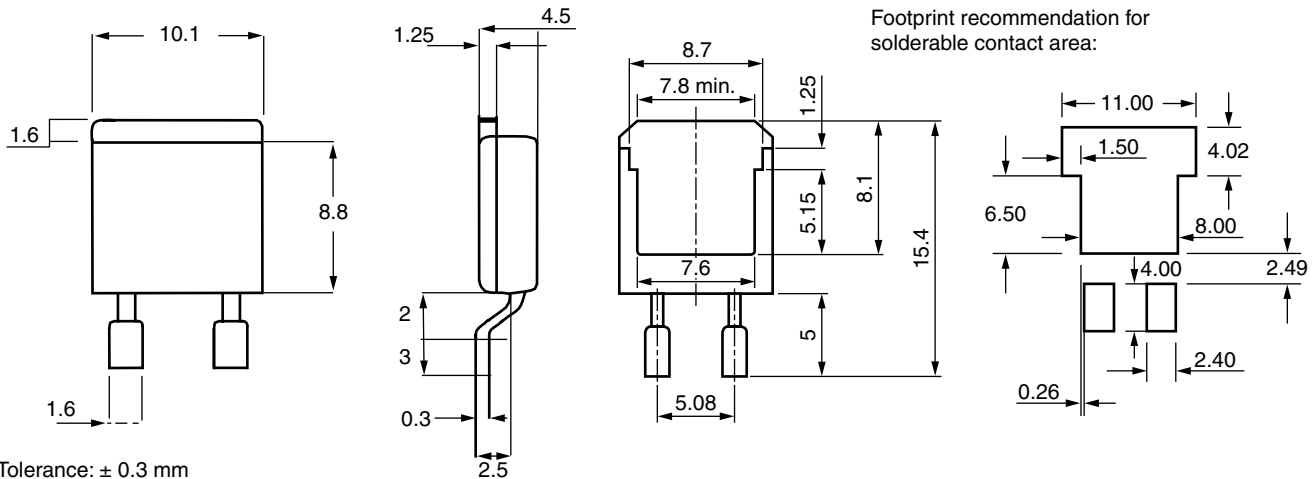

Notes

- For the assembly on board, we recommend the lead (Pb)-free thermal profile as per J-STD-020C
- Power dissipation is 3.3 W at an ambient temperature of 25 °C when mounted on a double sided copper board using FR4 standard, 70 μm of copper, 39 x 30 x 1.6 mm

ELECTRICAL SPECIFICATIONS	
Resistance Range	0.01 Ω to 550 kΩ
Tolerances (Standard)	± 1 % to 10 %
Power Rating and Thermal Resistance	35 W at 25 °C (case temperature) R _{TH(j-c)} : 4.28 °C/W
Temperature Coefficient	See Special Features table Standard: ± 150 ppm/°C
Limiting Element Voltage U _L	250 V
Dielectric Strength IEC 60115-1	2000 V _{rms} - 1 min - 10 mA max. (between terminals and board)
Insulation Resistance	≥ 10 ⁶ MΩ
Inductance	≤ 0.1 μH
Critical Resistance	3.12 KΩ

SPECIAL FEATURES				
Resistance Values	≥ 0.010	≥ 0.045	≥ 0.1	≥ 0.5
Tolerances	± 1 % at ± 10 %			
Requirement Temperature Coefficient (TCR) (- 55 °C + 150 °C) IEC 60115-1	± 1100 ppm/°C	± 700 ppm/°C	± 250 ppm/°C	± 150 ppm/°C



Surface Mounted Power Resistor
Thick Film Technology

Vishay Sfernice

MECHANICAL SPECIFICATIONS	
Mechanical Protection	Molded
Resistive Element	Thick film
Substrate	Alumina
Connections	Tinned copper
Weight	2.2 g max.

ENVIRONMENTAL SPECIFICATIONS	
Temperature Range	- 55 °C to 175 °C
Flammability	IEC 60695-11-5 2 applications 30 s separated by 60 s

DIMENSIONS	
Standard package	TO-263 Style (D ² PAK)

POWER RATING

The temperature of the case should be maintained within the limits specified.

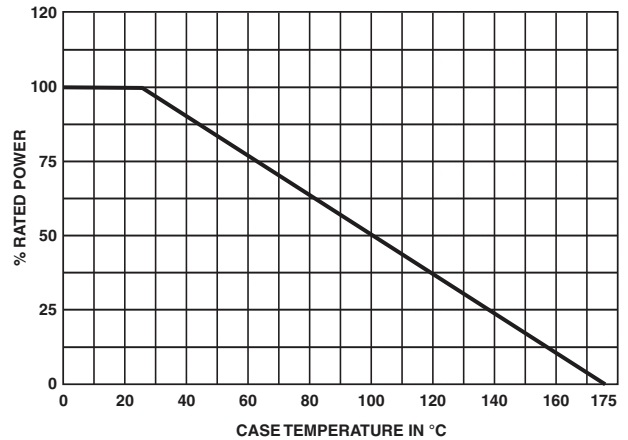

PERFORMANCE		
TESTS	CONDITIONS	REQUIREMENTS
Momentary Overload	IEC 60115-1 §4.13 1.7 Pr 5 s for $R < 2 \Omega$ 1.4 Pr 5 s for $R \geq 2 \Omega$ $U_s < 1.5 U_L$	$\pm (0.25 \% + 0.005 \Omega)$
Rapid Temperature Change	IEC 60115-1 Test Na 5 cycles - 1 h - 55 °C to + 175 °C	$\pm (0.5 \% + 0.005 \Omega)$
Load Life	IEC 60115-1 1000 h at + 25 °C	$\pm (1 \% + 0.005 \Omega)$
Humidity (Steady State)	IEC 60115-1 IEC 60068-2-3 Test Ca: 56 days RH 95 %	$\pm (0.5 \% + 0.005 \Omega)$
Vibration	MIL STD 202 Method 204 - Test D 10 to 2000 Hz	$\pm (0.2 \% + 0.005 \Omega)$
Terminal Strength	IEC 60115-1 Test Ua1/Tensile: 20 N/10 s	$\pm (0.2 \% + 0.005 \Omega)$
Shock	IEC 60115-1 IEC 60068-2-27 Saw-tooth: 100 gn/6 ms	$\pm (0.5 \% + 0.005 \Omega)$

ASSEMBLY SPECIFICATIONS		
For the assembly on board, we recommend the lead (Pb)-free thermal profile as per J-STD-020C		
TESTS	CONDITIONS	REQUIREMENTS
Resistance to Soldering Heat	IEC 60115-1 IEC 60068-2-58 Solder bath method: 270 °C/10 s	$\pm (0.5 \% + 0.005 \Omega)$
Moisture Sensitivity Level (MSL)	IPC/JEDEC J-STD-020C 85 °C/85 % RH/168 h	Level: 1 + pass requirements of TCR overload and dielectric strength after MSL



CHOISE OF THE BOARD

The user must choose the board according to the working conditions of the component (power, room temperature). Maximum working temperature must not exceed 155 °C. The dissipated power is simply calculated by the following ratio:

$$P = \frac{\Delta T}{[R_{TH(j-c)}] + [R_{TH(c-a)}]}$$

P: Expressed in W

ΔT: Difference between maximum working temperature and room temperature

R_{TH(j-c)}: Thermal resistance value measured between resistive layer and outer side of the resistor. It is the thermal resistance of the component: 4.28 °C/W.

R_{TH(c-a)}: Thermal resistance value measured between outer side of the resistor and room temperature. It is the thermal resistance of the solder layer (according the quality of the soldering) and the thermal resistance of the board.

Example:

R_{TH(c-a)} for D2TO35 power rating 3.5 W at ambient temperature + 25 °C.

Thermal resistance R_{TH(j-c)}: 4.28 °C/W

Considering equation (1) we have:

$$\Delta T = 175\text{ °C} - 25\text{ °C} = 150\text{ °C}$$

$$R_{TH(j-c)} + R_{TH(c-a)} = \Delta T/P = 150/3.5 = 42.8\text{ °C/W}$$

$$R_{TH(c-a)} = 42.8\text{ °C/W} - 4.28\text{ °C/W} = 38.52\text{ °C/W}$$

ACCIDENTAL OVERLOAD

In any case the applied voltage must be lower than the maximum overload voltage of 375 V. The values indicated on the graph below are applicable to resistors in air or mounted onto a board.

ENERGY CURVE

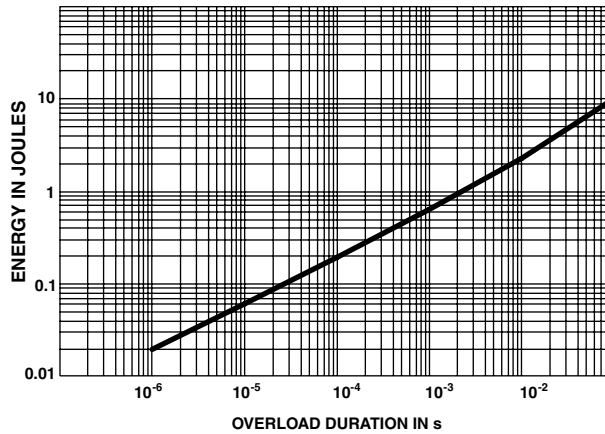

Single Pulse:

These informations are for a single pulse on a cold resistor at 25 °C (not already used for a dissipation) and for pulses of 100 ms maximum duration.

The formula used to calculate E is:

$$E = P \times t = \frac{U^2}{R} \times t$$

with:

- E (J): Pulse energy
- P (W): Pulse power
- t (s): Pulse duration
- U (V): Pulse voltage
- R (Ω): Resistor

The energy calculated must be less than that allowed by the graph.

Repetitive or Superimposed Pulses:

The following formula is used to calculate the “equivalent” energy of a repetitive pulse or the “equivalent energy” of a pulse on a resistor that is already dissipating power.

$$E_c = E \times \left(1 + \frac{P_a}{P_r}\right)$$

with:

- E_c (J): Equivalent pulse energy
- E (J): Known pulse energy
- P_r : Resistor power rating
- P_a : Mean power being dissipated

The energy calculated must be less than that allowed by the graph and the average power dissipated (P_a) must not exceed the continuous power of resistor.

PACKAGING

- Reel
- Tube
- Tape dimensions (mm) for reel:

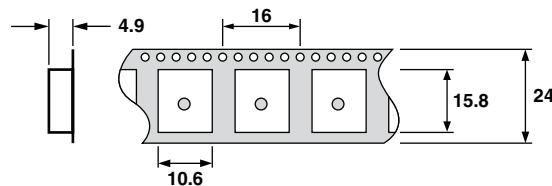
MARKING

Model, Style, Resistance Value (in Ω), Tolerance (in %), Manufacturing Date, Vishay Trademark

ORDERING INFORMATION						
D2TO	35	C	100 kΩ	$\pm 1\%$	XXX	e3
MODEL	STYLE	CONNECTIONS	RESISTANCE VALUE	TOLERANCE	CUSTOM DESIGN	LEAD (Pb)-FREE
				F = $\pm 1\%$ G = $\pm 2\%$ J = $\pm 5\%$ K = $\pm 10\%$	Optional on request: Shape, etc	

SAP PART NUMBERING GUIDELINES																
D	2	T	O	0	3	5	C	R	2	0	0	0	K	R	E	3
GLOBAL MODEL	SIZE	LEADS	OHMIC VALUE				TOLERANCE	PACKAGING	LEAD (Pb)-FREE							
D2TO	035	C = Surface mount	The first four digits are significant figures and the last digit specifies the number of zeros to follow. R designates decimal point. 48R70 = 48.7 Ω 48701 = 48 700 Ω 10002 = 100 000 Ω R0100 = 0.01 Ω R6800 = 0.68 Ω 27000 = 2700 Ω = 2K7 Ω				F = 1 % G = 2 % J = 5 % K = 10 %	R = Reel 500 pieces T = Tube 50 pieces	E3 = Pure tin							



Disclaimer

All product specifications and data are subject to change without notice.

Vishay Intertechnology, Inc., its affiliates, agents, and employees, and all persons acting on its or their behalf (collectively, "Vishay"), disclaim any and all liability for any errors, inaccuracies or incompleteness contained herein or in any other disclosure relating to any product.

Vishay disclaims any and all liability arising out of the use or application of any product described herein or of any information provided herein to the maximum extent permitted by law. The product specifications do not expand or otherwise modify Vishay's terms and conditions of purchase, including but not limited to the warranty expressed therein, which apply to these products.

No license, express or implied, by estoppel or otherwise, to any intellectual property rights is granted by this document or by any conduct of Vishay.

The products shown herein are not designed for use in medical, life-saving, or life-sustaining applications unless otherwise expressly indicated. Customers using or selling Vishay products not expressly indicated for use in such applications do so entirely at their own risk and agree to fully indemnify Vishay for any damages arising or resulting from such use or sale. Please contact authorized Vishay personnel to obtain written terms and conditions regarding products designed for such applications.

Product names and markings noted herein may be trademarks of their respective owners.