

## Precision Rotative Transducers, Conductive Plastic, Economic Series (ECS)



Low cost industrial motion transducers, conductive plastic track.

<b>SIZE</b>	09			
<b>MODEL</b>	78 RS	78 RB	78 PS	78 PB

**FEATURES**

- Size 09: ( $\frac{7}{8}$ " ) 22.2 mm
- Long life: 5 million cycles
- Bush or servo mounting types available
- Rear comolded terminals
- Cost effective solution for any industrial applications
- Material categorization: for definitions of compliance please see [www.vishay.com/doc?99912](http://www.vishay.com/doc?99912)

**RoHS**  
COMPLIANT

**QUICK REFERENCE DATA**

Sensor type	ROTATIONAL, conductive plastic
Output type	Output by turrets
Market appliance	Industrial
Dimensions	22.2 mm ( $\frac{7}{8}$ " ) dia.

**ELECTRICAL SPECIFICATIONS**

MODEL	78RS / 78RB	78PS / 78PB
Theoretical electrical angle (TEA)	(AEA) - 3°	
Independent linearity (over TEA)	A ≤ ± 1 %, on request: B ≤ ± 0.5 % C ≤ ± 0.35 %	A ≤ ± 2 %
Actual electrical angle (AEA)	340° ± 5°	
Ohmic values (R <sub>T</sub> )	1 kΩ - 2 kΩ - 5 kΩ - 10 kΩ (on request other values)	1 kΩ - 2 kΩ - 5 kΩ - 10 kΩ
Ohmic value tolerances at 20 °C	Standard: ± 20 %/special: ± 10 %	± 20 %
Output smoothness	0.1 %	
Maximum power rating at 70 °C	0.3 W	
Wiper current	Recommended: a few μA - 1 mA max. (continuous)	
Tap (current or voltage)	1: On request	n/a
Resistance load on wiper	≥ 1000 x R <sub>T</sub>	
End voltage	≤ 0.5 % DC	
Insulation resistance	≥ 1000 MΩ, 500 V <sub>DC</sub>	
Dielectric strength	≥ 500 V <sub>RMS</sub> , 50 Hz	

**MECHANICAL SPECIFICATIONS**

MODEL	78RS / 78RB	78PS / 78PB
Mechanical angle (MA)	360° continuous	
On request: stops	342° ± 5°	
Mounting type	Servo	Bushing
Shaft guiding	Sleeve bearings On request: ball bearings for servo mounting type	
Shaft	Stainless steel	
Option: flat or screw driver slot on shaft	On request	n/a
Termination	Turrets	
Wiper	Precious metal multi-finger contact	
Starting torque (N.cm)	≤ 0.5	
Torque on stops (N.cm)	≥ 20	
Weight (g)	Bushing 17 ± 3	Servo 12 ± 3

PERFORMANCE	
Life (10 <sup>6</sup> cycles)	5
Storage temperature range	-55 °C to +125 °C
Operating temperature range	-30 °C to +85 °C
Speed rotation (RPM)	150
Sine vibration on 3 axes	15 g from 10 Hz to 2000 Hz
Mechanical shocks on 3 axes	50 g - 11 ms - half sine

**Note**

- Nothing stated herein shall be construed as a guarantee of quality or durability

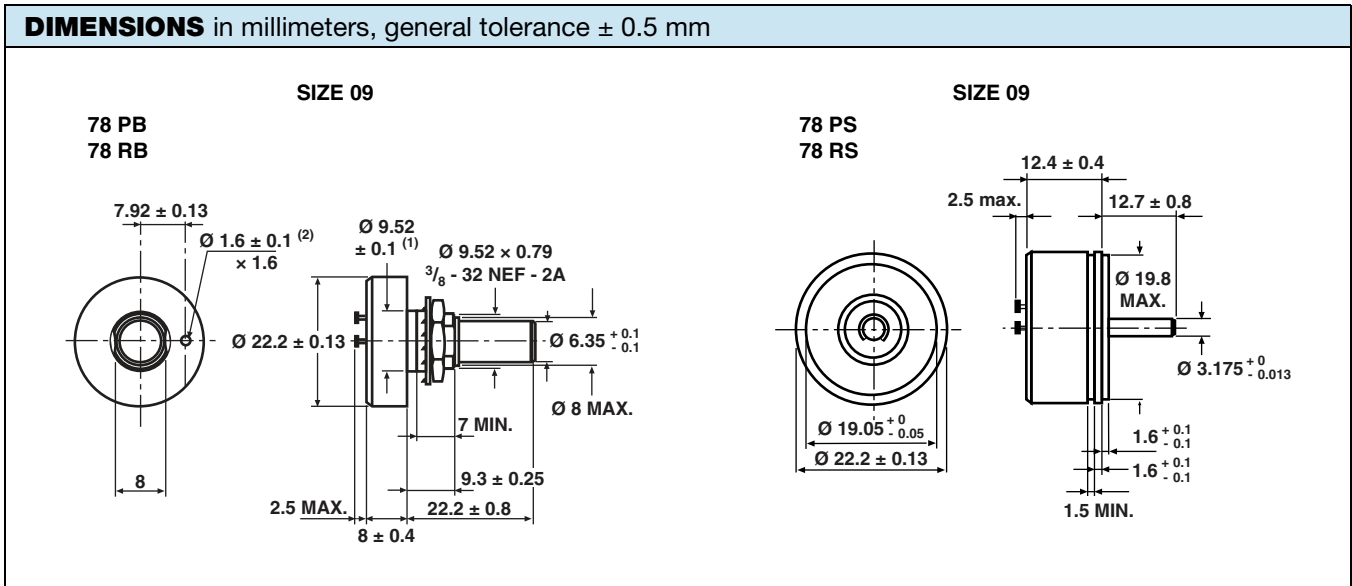

**Notes**

- (1) On request:  $\varnothing 10.3$  mm or  $12.3$  mm
- (2) On request: Without antirotation pin

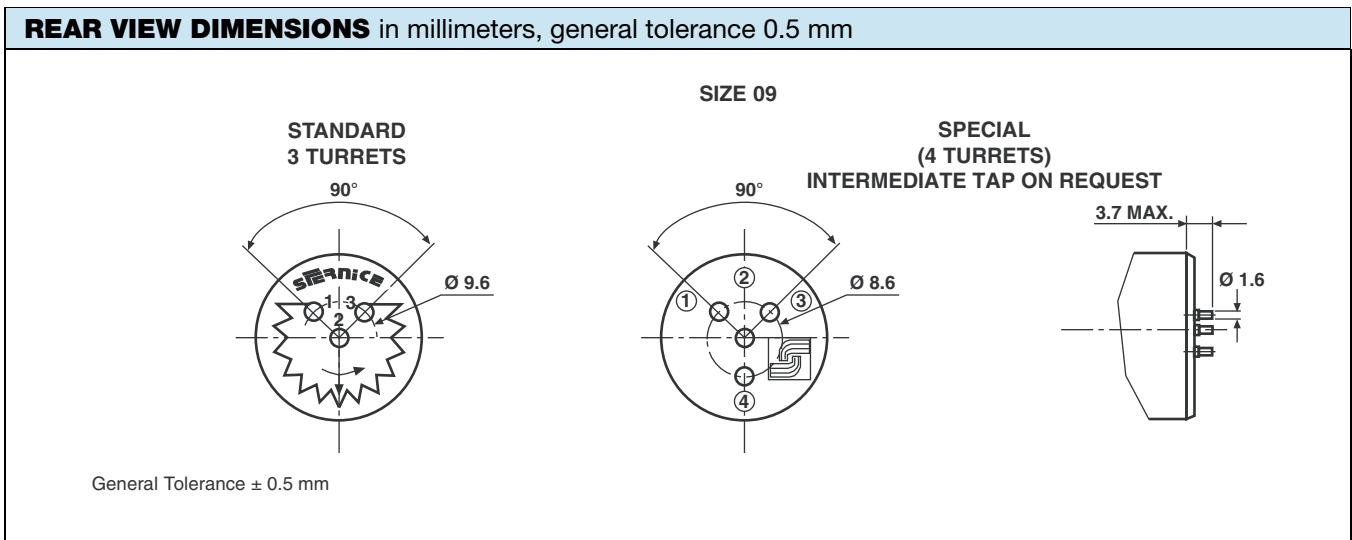



ORDERING INFORMATION / DESCRIPTION								
ECS	78	P	S	M	A	T	103	e4
SERIES	MODEL	TYPE	FIXATION	MECHANICAL STOPS	LINEARITY	TAP	OHMIC VALUE	LEAD FINISH
		P R	S: servo B: bushing	On request M	A: ± 1 % or ± 2 % B: ± 0.5 % C: ± 0.35 %	On request T: voltage U: current position to be specified	102: 1 kΩ 202: 2 kΩ 502: 5 kΩ 103: 10 kΩ	

SAP PART NUMBERING GUIDELINES			
ECS	78RB	B	102
SERIES	MODEL	LINEARITY	OHMIC VALUE



## Disclaimer

ALL PRODUCT, PRODUCT SPECIFICATIONS AND DATA ARE SUBJECT TO CHANGE WITHOUT NOTICE TO IMPROVE RELIABILITY, FUNCTION OR DESIGN OR OTHERWISE.

Vishay Intertechnology, Inc., its affiliates, agents, and employees, and all persons acting on its or their behalf (collectively, "Vishay"), disclaim any and all liability for any errors, inaccuracies or incompleteness contained in any datasheet or in any other disclosure relating to any product.

Vishay makes no warranty, representation or guarantee regarding the suitability of the products for any particular purpose or the continuing production of any product. To the maximum extent permitted by applicable law, Vishay disclaims (i) any and all liability arising out of the application or use of any product, (ii) any and all liability, including without limitation special, consequential or incidental damages, and (iii) any and all implied warranties, including warranties of fitness for particular purpose, non-infringement and merchantability.

Statements regarding the suitability of products for certain types of applications are based on Vishay's knowledge of typical requirements that are often placed on Vishay products in generic applications. Such statements are not binding statements about the suitability of products for a particular application. It is the customer's responsibility to validate that a particular product with the properties described in the product specification is suitable for use in a particular application. Parameters provided in datasheets and / or specifications may vary in different applications and performance may vary over time. All operating parameters, including typical parameters, must be validated for each customer application by the customer's technical experts. Product specifications do not expand or otherwise modify Vishay's terms and conditions of purchase, including but not limited to the warranty expressed therein.

Hyperlinks included in this datasheet may direct users to third-party websites. These links are provided as a convenience and for informational purposes only. Inclusion of these hyperlinks does not constitute an endorsement or an approval by Vishay of any of the products, services or opinions of the corporation, organization or individual associated with the third-party website. Vishay disclaims any and all liability and bears no responsibility for the accuracy, legality or content of the third-party website or for that of subsequent links.

Vishay products are not designed for use in life-saving or life-sustaining applications or any application in which the failure of the Vishay product could result in personal injury or death unless specifically qualified in writing by Vishay. Customers using or selling Vishay products not expressly indicated for use in such applications do so at their own risk. Please contact authorized Vishay personnel to obtain written terms and conditions regarding products designed for such applications.

No license, express or implied, by estoppel or otherwise, to any intellectual property rights is granted by this document or by any conduct of Vishay. Product names and markings noted herein may be trademarks of their respective owners.