

Single Turn Bushing Mount Hall Effect Sensor in Size 09 (22.2 mm)



FEATURES

- Accurate linearity down to: $\pm 0.5\%$
- All electrical angles available up to: 360° (no dead band)
- Long life: over 20M cycles
- Non contacting technology: Hall effect
- Model dedicated to all applications in harsh environments
- Robust tool machined aluminum housing
- Compliant to RoHS directive 2002/95/EC



ELECTRICAL SPECIFICATIONS		
PARAMETER	STANDARD	SPECIAL
Electrical Angle	90°, 180°, 270°, 360°	Any other angle upon request
Linearity	$\pm 1\%$	$\pm 0.5\%$
Supply Voltage	5 V _{DC} $\pm 10\%$	Other upon request
Supply Current	10 mA typical	16 mA for PWM output
Output Signal	Analog ratiometric 10 % to 90 % of V _{supply} or PWM 10 % to 90 % duty cycle	Other upon request
Over Voltage Protection	+ 20 V _{DC}	
Reverse Voltage Protection	- 10 V _{DC}	
Load Resistance Recommended	Min. 1 k Ω for analog output and PWM output	
Hysteresis	< 0.2 %	

MECHANICAL SPECIFICATIONS		
PARAMETER		
Mechanical Travel	360° continuous	
Bearing Type	Sleeve bearing	Ball bearing upon request
Standard	IP 50; other on request	
Weight	20 g ± 2 g	

ORDERING INFORMATION/DESCRIPTION									
631HE	0	A	1	W	A	1S22	XXXX	BO 10	e1
MODEL	FEATURES	LINEARITY	ELECTRICAL ANGLE	OUTPUT TYPE	OUTPUT SIGNAL	SHAFT TYPE	SPECIAL REQUEST	PACKAGING	LEAD FINISH
	0: Continuous rotation and antirotation pin 1: Continuous rotation and no antirotation pin	A: $\pm 1\%$ B: $\pm 0.5\%$	1: 90° 2: 180° 3: 270° 4: 360° 9: Other angles	W: Wires Z: Custom	A: Analog CW B: Analog CCW C: PWM CW D: PWM CCW Z: Other output	0: 6 mm 1: 6.35 mm 2: 3.175 mm 9: Special P: Plain S: Slotted Z: Other type		Box of 10 pieces	
Shaft length from mounting face 22 mm to 72 mm max. per step of 5 mm									

SAP PART NUMBERING GUIDELINES							
631HE	1	B	9	Z	C	0P27	XXXX
MODEL	MECHANICAL FEATURES	LINEARITY	ELECTRICAL ANGLE	OUTPUT TYPE	OUTPUT SIGNAL	SHAFT TYPE	SPECIAL REQUEST



V_{OUT} ANALOG

Operating Temperature	85 °C	125 °C
Diagnostic High Level	96 % min.	96 % min.
Diagnostic Low Level	2 % max.	4 % max.

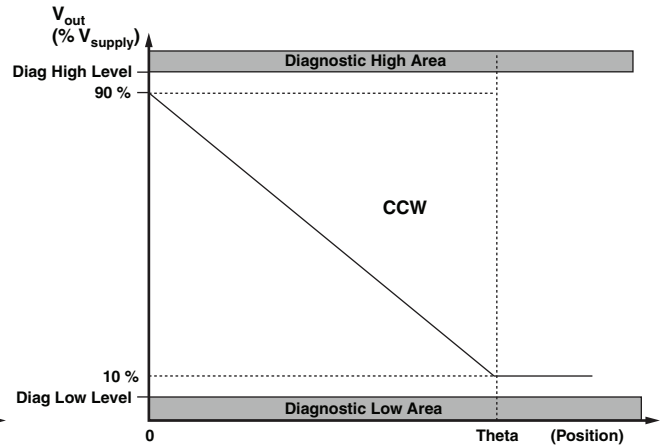
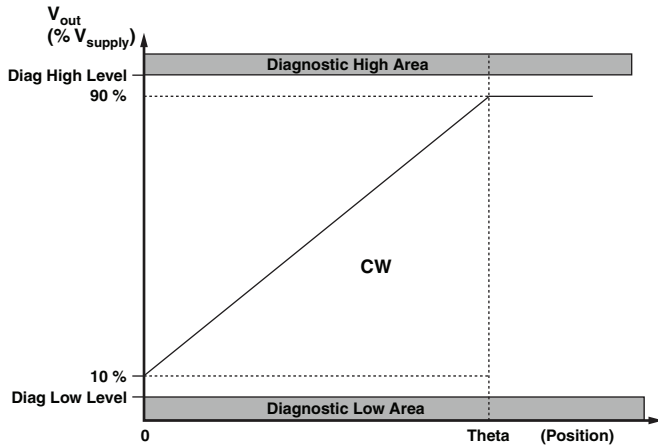

V_{OUT} PWM

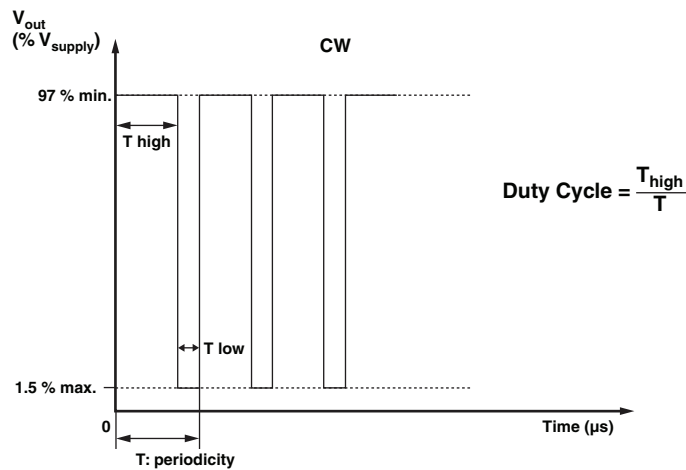

DIAGNOSTIC MODES			
FAILURE	V_{out} Analog $R_{pull-up}$	V_{out} Analog $R_{pull-down}$	V_{out} PWM $R_{pull-up} = 1\text{ k}\Omega$ $V_{pull-up} = V_{supply} = 5\text{ V}$
1: Broken GND	Diagnostic high area	Diagnostic low area	> 97 % V_{supply} without modulation
2: Broken V_{out}	Diagnostic high area	Diagnostic low area	> 97 % V_{supply} without modulation
3: Broken V_{supply}	Diagnostic high area	Diagnostic low area	> 97 % V_{supply} without modulation
Over Voltage $V_{supply} > 7\text{ V}$	Diagnostic high area	Diagnostic low area	> 97 % V_{supply} without modulation
Under Voltage $V_{supply} < 2.7\text{ V}$	Diagnostic high area	Diagnostic low area	> 97 % V_{supply} without modulation

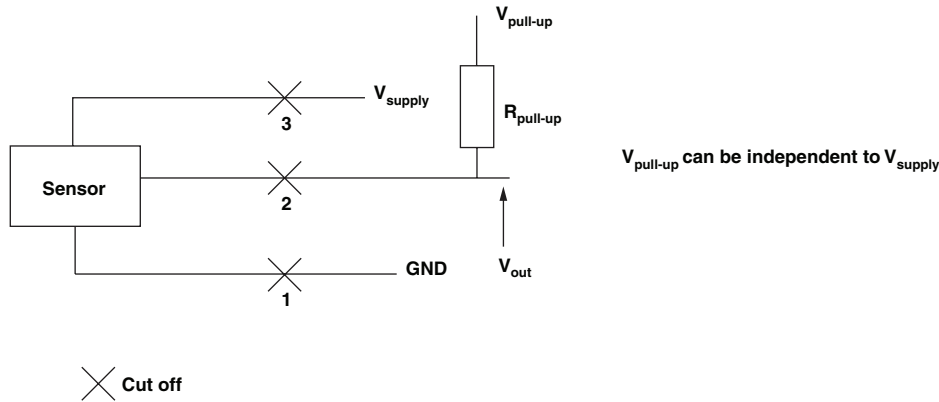

ENVIRONMENTAL SPECIFICATIONS	
Vibrations	20 g from 10 Hz to 2000 Hz
Shocks	3 shocks/axis; 50 g half a sine 11 ms
Operating Temperature Range	- 45 °C; + 125 °C
Life	20M of cycles
Rotational Speed (Max.)	120 RPM
Immunity to Radiated Electromagnetic Disturbances	200 V/m 150 kHz/1 GHz
Immunity to Power Frequency Magnetic Field	200 A/m 50 Hz/60 Hz
Radiated Electromagnetic Emissions	30 MHz/1 GHz < 30 dB $\mu\text{V}/\text{m}$
Electrostatic Discharges	Contact discharges: $\pm 4\text{ kV}$ Air discharges: $\pm 8\text{ kV}$
Materials	
Housing	Aluminum anodized
Shaft	Stainless steel
Output	3 lead wires
Bushing Mount Hardware	
Lockwasher Internal Tooth	Steel nickel plated
Panel Nut	Brass nickel plated

DIMENSIONS in millimeters

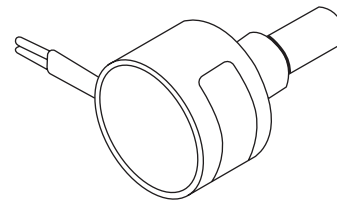
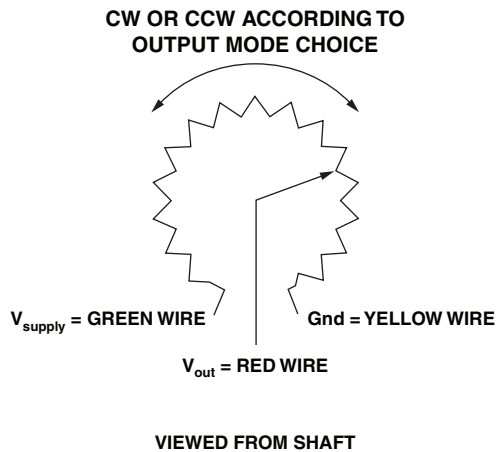
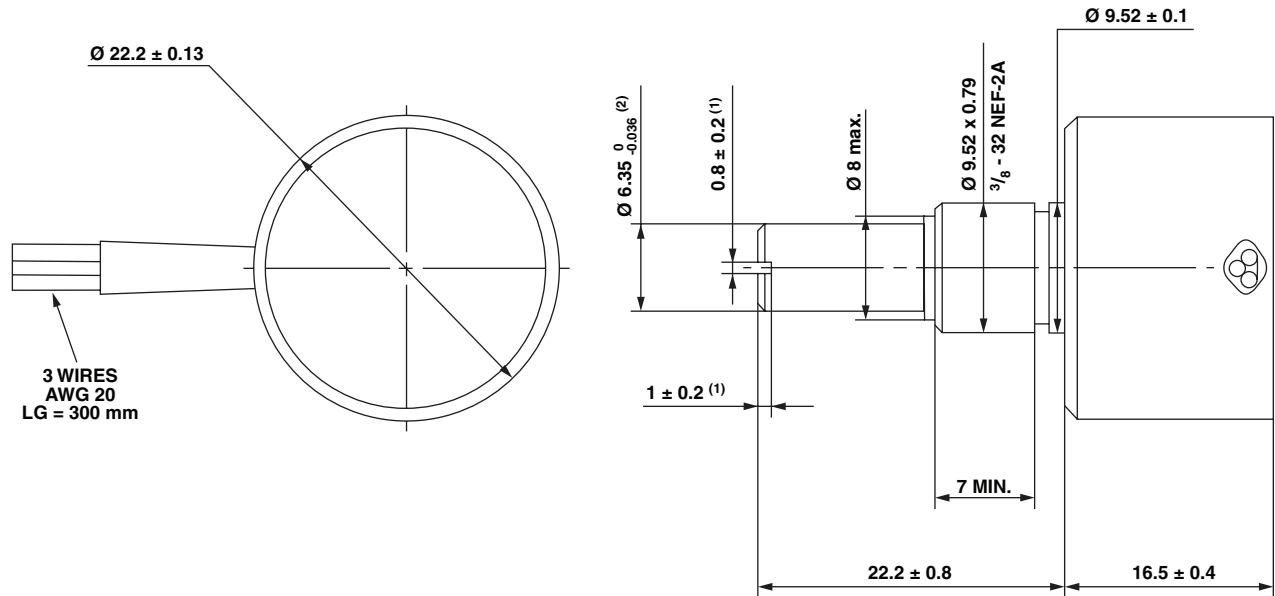

Dimensions in millimeter

Delivered with nut and washer

Notes

- (1) For version slotted shaft
- (2) For shaft type "1"

MARKING	
Unit Identification	Manufacturer's name and complete sap part reference, date code, and wiring correspondance: colors versus connections.



Disclaimer

ALL PRODUCT, PRODUCT SPECIFICATIONS AND DATA ARE SUBJECT TO CHANGE WITHOUT NOTICE TO IMPROVE RELIABILITY, FUNCTION OR DESIGN OR OTHERWISE.

Vishay Intertechnology, Inc., its affiliates, agents, and employees, and all persons acting on its or their behalf (collectively, "Vishay"), disclaim any and all liability for any errors, inaccuracies or incompleteness contained in any datasheet or in any other disclosure relating to any product.

Vishay makes no warranty, representation or guarantee regarding the suitability of the products for any particular purpose or the continuing production of any product. To the maximum extent permitted by applicable law, Vishay disclaims (i) any and all liability arising out of the application or use of any product, (ii) any and all liability, including without limitation special, consequential or incidental damages, and (iii) any and all implied warranties, including warranties of fitness for particular purpose, non-infringement and merchantability.

Statements regarding the suitability of products for certain types of applications are based on Vishay's knowledge of typical requirements that are often placed on Vishay products in generic applications. Such statements are not binding statements about the suitability of products for a particular application. It is the customer's responsibility to validate that a particular product with the properties described in the product specification is suitable for use in a particular application. Parameters provided in datasheets and/or specifications may vary in different applications and performance may vary over time. All operating parameters, including typical parameters, must be validated for each customer application by the customer's technical experts. Product specifications do not expand or otherwise modify Vishay's terms and conditions of purchase, including but not limited to the warranty expressed therein.

Except as expressly indicated in writing, Vishay products are not designed for use in medical, life-saving, or life-sustaining applications or for any other application in which the failure of the Vishay product could result in personal injury or death. Customers using or selling Vishay products not expressly indicated for use in such applications do so at their own risk and agree to fully indemnify and hold Vishay and its distributors harmless from and against any and all claims, liabilities, expenses and damages arising or resulting in connection with such use or sale, including attorneys fees, even if such claim alleges that Vishay or its distributor was negligent regarding the design or manufacture of the part. Please contact authorized Vishay personnel to obtain written terms and conditions regarding products designed for such applications.

No license, express or implied, by estoppel or otherwise, to any intellectual property rights is granted by this document or by any conduct of Vishay. Product names and markings noted herein may be trademarks of their respective owners.