

## High Power Multi-Tiered Conductor Hybrid Circuit Substrate



Product may not be to scale

### FEATURES

- Copper power lines up to 5000 microinches thick
- Gold small signal lines  $\pm$  100 microinches width tolerance
- Temperatures to 350 °C
- Substrate material: Alumina, Beryllium Oxide or Aluminum Nitride
- Excellent adhesion
- Metallized through holes
- Filled vias
- Resistors available
- Sizes up to 4 inches x 4 inches

Vishay Electro-Films (EFI) has developed a thin film process that has the unique capability of incorporating up to 5000 microinches thick plated copper conductors on the same substrate with standard 100 to 300 microinches thick conductors.

Some hybrid circuit applications require thick copper conductors for the power lines but standard thickness small signal lines to maintain tight line width control of critical elements. For example, a microwave application may require high power bias current to GaAs or other semiconductor devices while also requiring tight line width control to obtain good high frequency performance for large couplers, filters or other critical signal patterns.

For standard, high power, low frequency hybrid circuit substrates, thick copper plating alone is ideal. The 5000 microinches thick plated copper has a resistivity of less than 0.15 mΩ/square.

In most cases, the dc or low frequency copper power lines are overplated with nickel and gold to prevent oxidation, permitting high temperature processing and operation. The conductor material for the small signal lines is normally gold. Several substrate materials and various adhesion metals are available.

Consult Applications Engineer to discuss your requirements in detail to jointly develop the optimum metalization structure for your application.

### TYPICAL CROSS SECTION

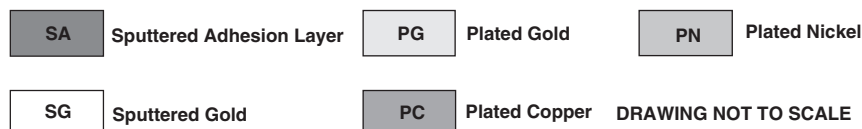
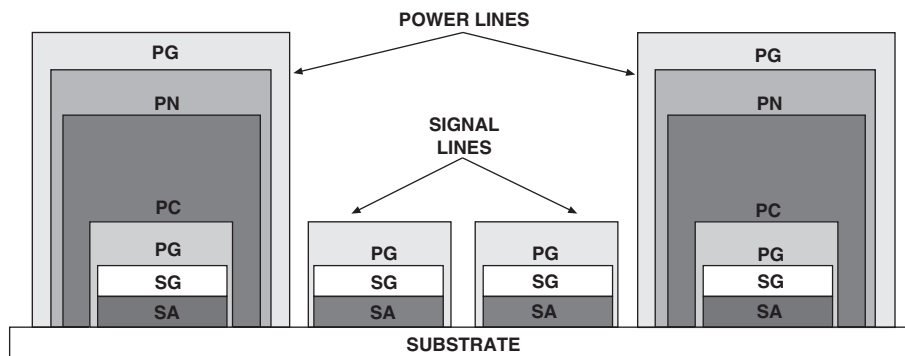

METALLIZED WAFERS



## Disclaimer

ALL PRODUCT, PRODUCT SPECIFICATIONS AND DATA ARE SUBJECT TO CHANGE WITHOUT NOTICE TO IMPROVE RELIABILITY, FUNCTION OR DESIGN OR OTHERWISE.

Vishay Intertechnology, Inc., its affiliates, agents, and employees, and all persons acting on its or their behalf (collectively, "Vishay"), disclaim any and all liability for any errors, inaccuracies or incompleteness contained in any datasheet or in any other disclosure relating to any product.

Vishay makes no warranty, representation or guarantee regarding the suitability of the products for any particular purpose or the continuing production of any product. To the maximum extent permitted by applicable law, Vishay disclaims (i) any and all liability arising out of the application or use of any product, (ii) any and all liability, including without limitation special, consequential or incidental damages, and (iii) any and all implied warranties, including warranties of fitness for particular purpose, non-infringement and merchantability.

Statements regarding the suitability of products for certain types of applications are based on Vishay's knowledge of typical requirements that are often placed on Vishay products in generic applications. Such statements are not binding statements about the suitability of products for a particular application. It is the customer's responsibility to validate that a particular product with the properties described in the product specification is suitable for use in a particular application. Parameters provided in datasheets and/or specifications may vary in different applications and performance may vary over time. All operating parameters, including typical parameters, must be validated for each customer application by the customer's technical experts. Product specifications do not expand or otherwise modify Vishay's terms and conditions of purchase, including but not limited to the warranty expressed therein.

Except as expressly indicated in writing, Vishay products are not designed for use in medical, life-saving, or life-sustaining applications or for any other application in which the failure of the Vishay product could result in personal injury or death. Customers using or selling Vishay products not expressly indicated for use in such applications do so at their own risk and agree to fully indemnify and hold Vishay and its distributors harmless from and against any and all claims, liabilities, expenses and damages arising or resulting in connection with such use or sale, including attorneys fees, even if such claim alleges that Vishay or its distributor was negligent regarding the design or manufacture of the part. Please contact authorized Vishay personnel to obtain written terms and conditions regarding products designed for such applications.

No license, express or implied, by estoppel or otherwise, to any intellectual property rights is granted by this document or by any conduct of Vishay. Product names and markings noted herein may be trademarks of their respective owners.

## Material Category Policy

**Vishay Intertechnology, Inc. hereby certifies that all its products that are identified as RoHS-Compliant fulfill the definitions and restrictions defined under Directive 2011/65/EU of The European Parliament and of the Council of June 8, 2011 on the restriction of the use of certain hazardous substances in electrical and electronic equipment (EEE) - recast, unless otherwise specified as non-compliant.**

**Please note that some Vishay documentation may still make reference to RoHS Directive 2002/95/EC. We confirm that all the products identified as being compliant to Directive 2002/95/EC conform to Directive 2011/65/EU.**