

0.45 Ω, Low Voltage Dual SPDT Analog Switch with Negative Swing Audio Capability

DESCRIPTION

The DG2750 is a dual SPDT low on-resistance switch designed to from a single 1.6 V to 5.5 V power supply. It is a bi-directional switch, and is capable of switching negative swing audio without the need for a coupling capacitor. With a single power supply, the audio signal can swing over the range from $(V+ - 5)$ to $V+$.

Guaranteed to operate with 1.4 V logic when $V+$ is in the range of 2.7 V to 5.5 V, the DG2750 will allow an easy interface with low voltage DSP or ASIC control logic.

The DG2750 is built on sub micron CMOS low voltage process technology, has very low quiescent current, and provides greater than 600 mA latch-up protection, as tested per JESD78.

The DG2750 is assembled in compact mQFN10, 1.4 mm x 1.8 mm x 0.55 mm and ultra thin UTMQFN of 0.35 mm thickness.

As a committed partner to the community and the environment, Vishay Siliconix manufactures this product with lead (Pb)-free device termination. The miniQFN-10 package has a nickel-palladium-gold device termination and is represented by the lead (Pb)-free “-E4” suffix to the ordering part number. The nickel-palladium-gold device terminations meet all JEDEC® standards for reflow and MSL rating.

As a further sign of Vishay Siliconix’s commitment, the DG2750 is fully RoHS-complaint and halogen-free.

FEATURES

- 1.6 V to 5.5 V single power rail operation
- Capable to switch negative swing audio without DC blocking capacitor
- Low signal distortion: THD+N < -98 dB
- Low on-resistance
- 1.4 V high logic
- Latch-up current > 600 mA (JESD78)
- ESD (HBM): 8 kV
- Reduced power consumption
- Reduce board space
- Material categorization: for definitions of compliance please see www.vishay.com/doc?99912



APPLICATIONS

- Cellular phones
- Portable media players
- Computer and game machine
- Handheld healthcare and instruments

FUNCTIONAL BLOCK DIAGRAM AND PIN CONFIGURATION

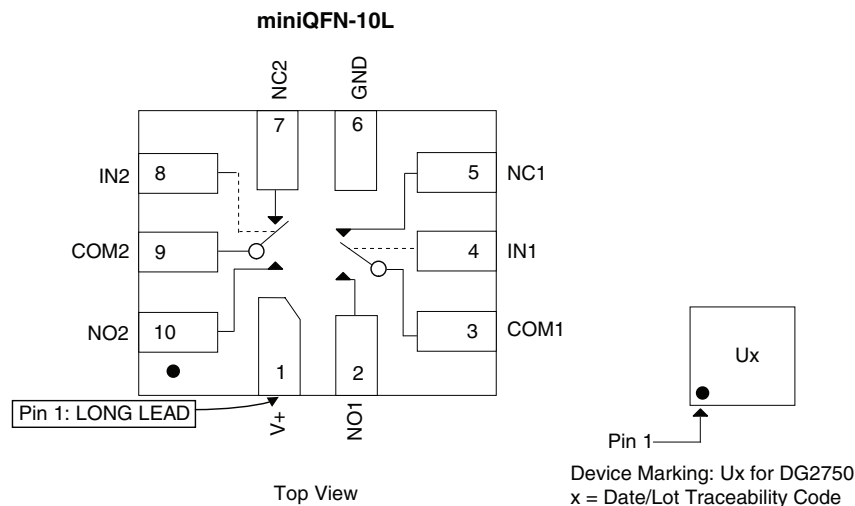



ORDERING INFORMATION			
PART NUMBER	TEMPERATURE RANGE	PACKAGE	SIZE
DG2750DN-T1-E4	-40 °C to +85 °C	miniQFN-10	1.4 mm x 1.8 mm x 0.55 mm
DG2750DN1-T1-GE4		UTMQFN-10	1.4 mm x 1.8 mm x 0.35 mm

TRUTH TABLE, DG2750		
IN1 (PIN 4)	IN2 (PIN 8)	FUNCTION
0	X	COM1 = NC1
1	X	COM1 = NO1
X	0	COM2 = NC2
X	1	COM2 = NO2

ABSOLUTE MAXIMUM RATINGS (T _A = 25 °C, unless otherwise noted)			
PARAMETER		LIMIT	UNIT
Reference to GND	V+, IN	-0.3 to +6	V
	COM, NO, NC ^a	(V+) -5.5 or -2.5 whichever higher, (V+ + 0.3)	
Current (Any Terminal except COM, NO, NC, IN)		30	mA
Continuous Current (COM, NO, NC, IN)		± 250	
Peak Current (Pulsed at 1 ms, 10 % Duty Cycle)		± 500	
Storage Temperature (D Suffix)		-65 to +150	°C
Power Dissipation (Packages) ^b	miniQFN-10 ^c	208	mW
ESD (Human Body Model) I/O to GND		8	kV
Latch-up (per JEDEC78)		600	mA

Notes

- a. Signals on COM, NO, NC, exceeding V+ will be clamped by internal diodes. Limit forward diode current to maximum current ratings
- b. All leads welded or soldered to PC board
- c. Derate 2.6 mW/°C above 70 °C

SPECIFICATIONS (V ₊ = 2.7 V, ± 10 %)							
PARAMETER	SYMBOL	TEST CONDITIONS OTHERWISE UNLESS SPECIFIED	TEMP. ^a	LIMITS -40 °C to +85 °C			UNIT
				MIN. ^b	TYP. ^c	MAX. ^b	
Analog Switch							
Analog Signal Range ^d	V _{ANALOG}		Full	-2.5	-	V+	V
On-Resistance	R _{DS(on)}	V ₊ = 2.7 V, V _S = (V+) -4.5 V, -1 V, 0 V, 1 V, 2 V, V+), I _S = 100 mA	Room	-	0.45	1	Ω
On-Resistance Match	ΔR _{ON}		Full	-	-	1.3	
On-Resistance Flatness	R _{ON} Flatness		Room	-	0.1	-	
			Room	-	0.3	-	
Switch Off Leakage Current	I _{NO/NC(off)}	V ₊ = 2.7 V, V _{NC/NO} = -2.5 V or 2.5 V, V _{COM} = 2.5 V or -2.5 V	Room	-	50	-	nA
	I _{COM(off)}		Full	-250	-	250	
Channel On Leakage Current	I _{COM(on)}		Room	-	50	-	
			Full	-250	-	250	
Digital Control							
Input Voltage High	V _{INH}	V ₊ = 2.7 V to 4.3 V	Full	1.4	-	-	V
Input Voltage Low	V _{INL}		Full	-	-	0.6	
Input Capacitance	C _{IN}		Room	-	6.5	-	pF
Input Current	I _{INL} or I _{INH}	V _{IN} = 0 or V+	Full	-1	-	1	μA

SPECIFICATIONS ($V_+ = 2.7\text{ V}, \pm 10\%$)								
PARAMETER	SYMBOL	TEST CONDITIONS OTHERWISE UNLESS SPECIFIED	TEMP. ^a	LIMITS -40 °C to +85 °C			UNIT	
				MIN. ^b	TYP. ^c	MAX. ^b		
Dynamic Characteristics								
Break-Before-Make Time ^{e, d}	t_{BBM}	$V_+ = 3\text{ V}, V_S = 1.5\text{ V}, R_L = 50\ \Omega,$ $C_L = 35\text{ pF}$	Room	800	1160	-	ns	
			Full	1000	-	-		
Enable Turn-On Time ^{e, d}	$t_{\text{ON(EN)}}$		Room	-	1200	2100		
			Full	-	-	2500		
Enable Turn-Off Time ^{e, d}	$t_{\text{OFF(EN)}}$		Room	-	33	130		
			Full	-	-	150		
Charge Injection ^d	Q_{INJ}	$C_L = 1\text{ nF}, R_{\text{GEN}} = 0\ \Omega, V_{\text{GEN}} = 0\text{ V}$	Room	-	4	-	pC	
Total Harmonic Distortion Plus Noise ^d	THD+N	$f = 20\text{ Hz to } 20\text{ kHz}, V_{\text{COM}} = 0.5\text{ V}_{\text{P-P}},$ $R_S = R_L = 600\ \Omega; \text{DC bias} = 0\text{ V}$		-	< -98	-	dB	
Off-Isolation ^d	OIRR	$V_+ = 3\text{ V}, R_L = 50\ \Omega, C_L = 5\text{ pF},$ $f = 300\text{ kHz}$		-	-54	-	dB	
Crosstalk ^{d, f}	X_{TALK}			-	-60	-	dB	
Bandwidth ^d	BW	$V_+ = 3\text{ V}, R_L = 50\ \Omega, -3\text{ dB}$		-	49	-	MHz	
Channel-Off Capacitance ^d	$C_{\text{NC/NO(off)}}$	$V_+ = 3\text{ V}, f = 1\text{ MHz}$		-	36	-	pF	
Channel-On Capacitance ^d	$C_{\text{COM/NC/NO(on)}}$			-	106	-		
Power Supply								
Power Supply Range	V_+				1.6	-	5.5	V
Power Supply Current	I_+	$V_{\text{IN}} = 0\text{ V}, \text{ or } V_+$	Full	-	-	2	μA	

Notes

- Room = 25 °C, Full = as determined by the operating suffix
- The algebraic convention whereby the most negative value is a minimum and the most positive a maximum, is used in this data sheet
- Typical values are for design aid only, not guaranteed nor subject to production testing
- Guarantee by design, not subjected to production test
- $V_{\text{IN}} = V_+$ voltage to perform proper function
- Crosstalk measured between channels

Stresses beyond those listed under "Absolute Maximum Ratings" may cause permanent damage to the device. These are stress ratings only, and functional operation of the device at these or any other conditions beyond those indicated in the operational sections of the specifications is not implied. Exposure to absolute maximum rating conditions for extended periods may affect device reliability.

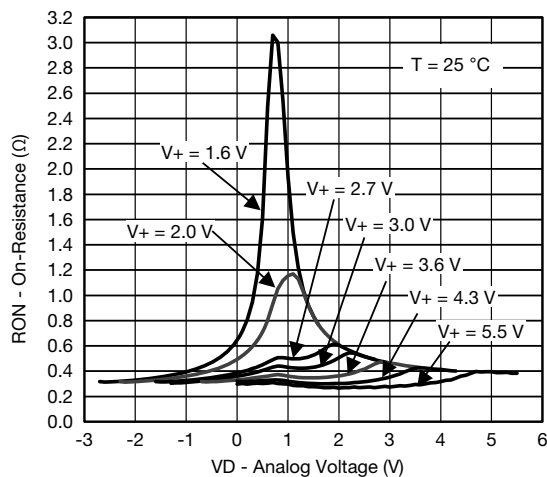
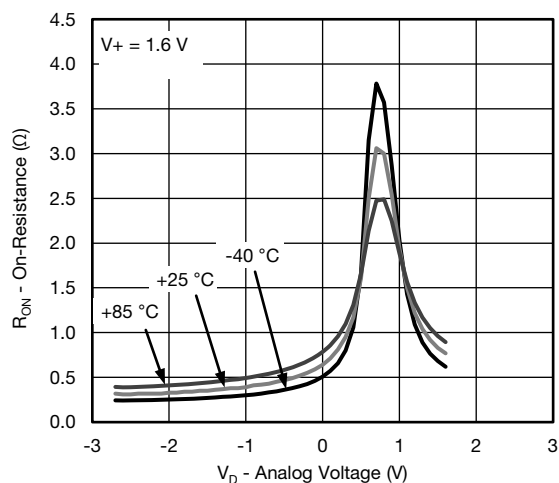
TYPICAL CHARACTERISTICS (25 °C, unless otherwise noted)

On-Resistance vs. V_D and Single Supply Voltage

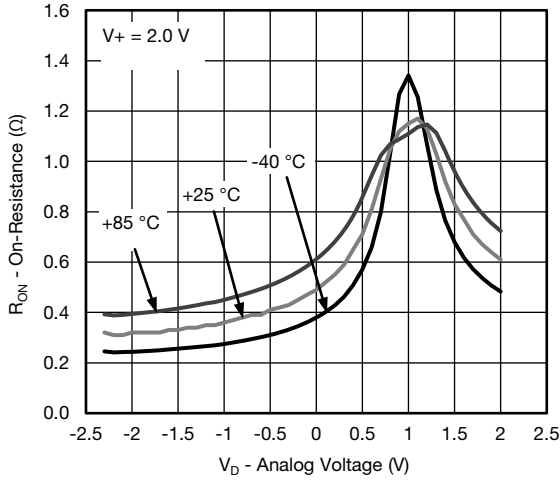
On-Resistance vs. Analog Voltage and Temperature

TYPICAL CHARACTERISTICS (25 °C, unless otherwise noted)

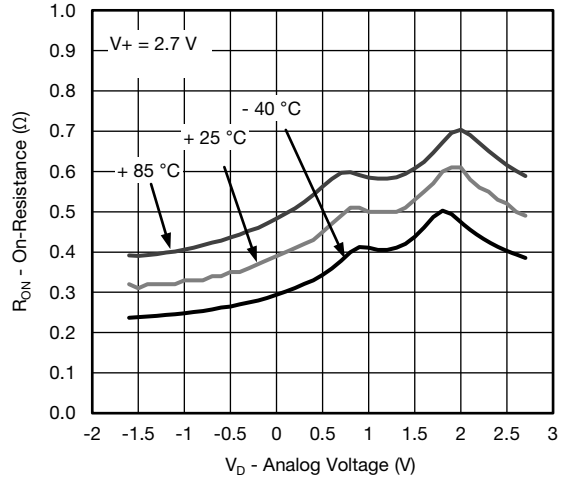

On-Resistance vs. Analog Voltage and Temperature



On-Resistance vs. Analog Voltage and Temperature

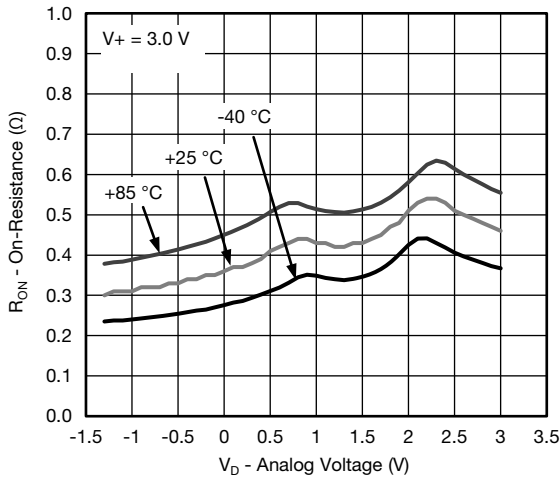

On-Resistance vs. Analog Voltage and Temperature

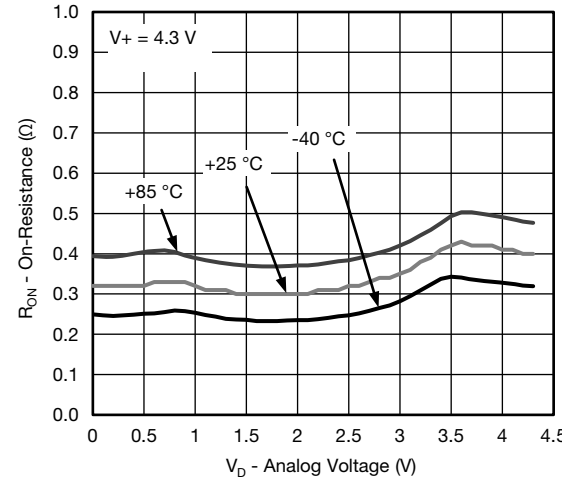

On-Resistance vs. Analog Voltage and Temperature

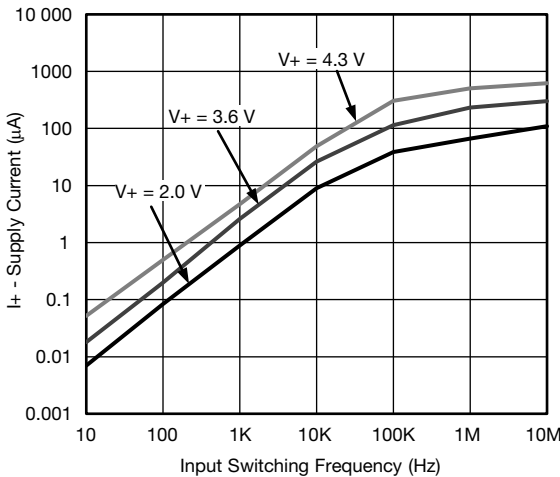

Supply Current vs. Input Switching Frequency

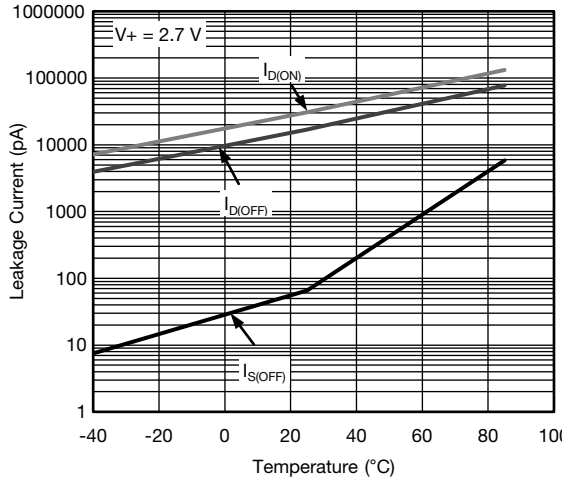

Leakage Current vs. Temperature

TYPICAL CHARACTERISTICS (25 °C, unless otherwise noted)

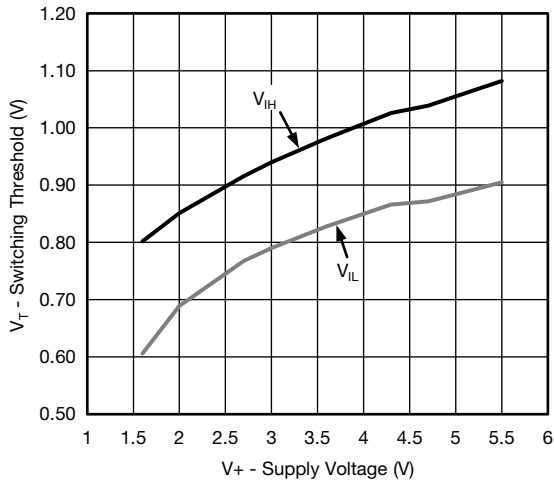

Switching Threshold vs. Supply Voltage

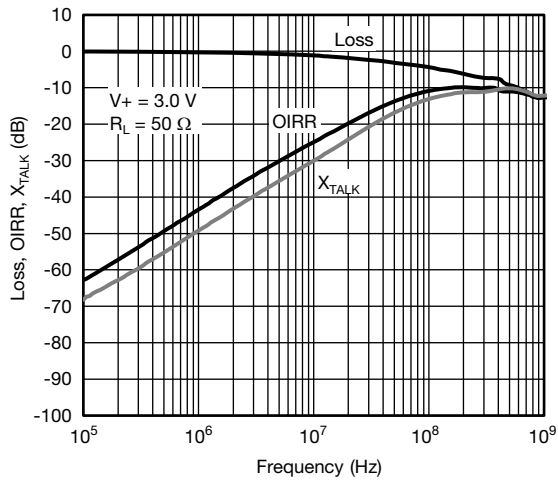

Insertion Loss, Off-Isolation, Crosstalk vs. Frequency

TEST CIRCUITS

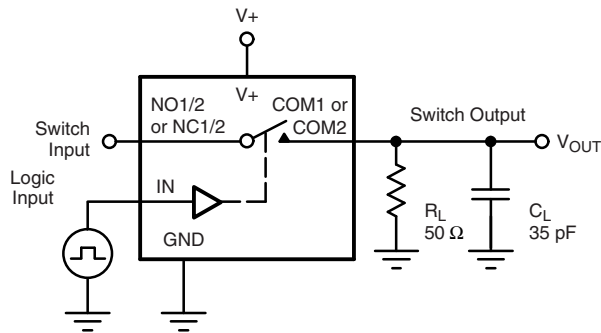

C_L (includes fixture and stray capacitance)

$$V_{OUT} = V_{COM} \left(\frac{R_L}{R_L + R_{ON}} \right)$$

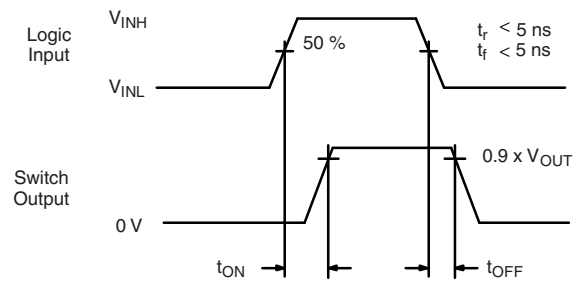

Logic "1" = Switch on
Logic input waveforms inverted for switches that have the opposite logic sense.

Fig. 1 - Switching Time

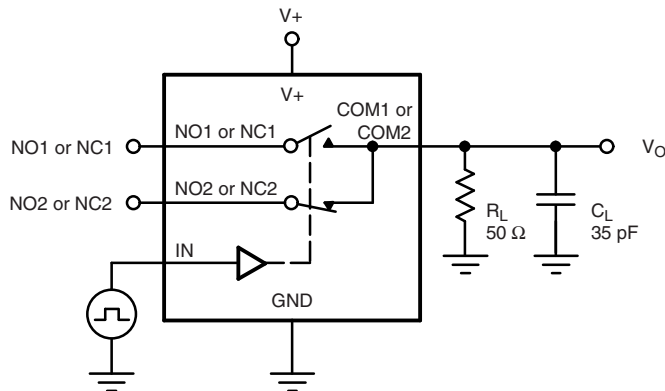

C_L (includes fixture and stray capacitance)

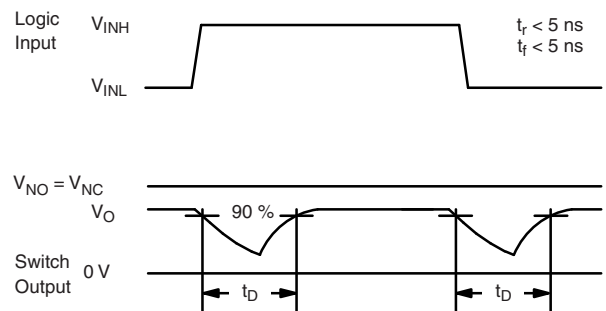
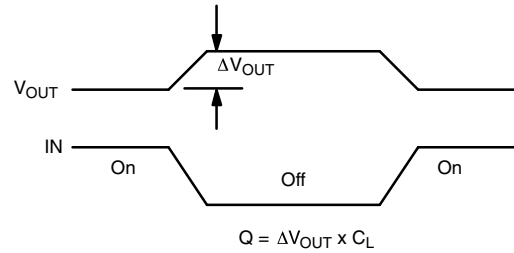
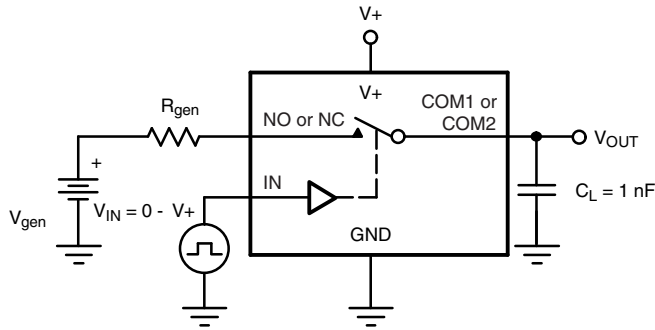

Fig. 2 - Break-Before-Make Interval

TEST CIRCUITS



IN depends on switch configuration: input polarity determined by sense of switch.

Fig. 3 - Charge Injection

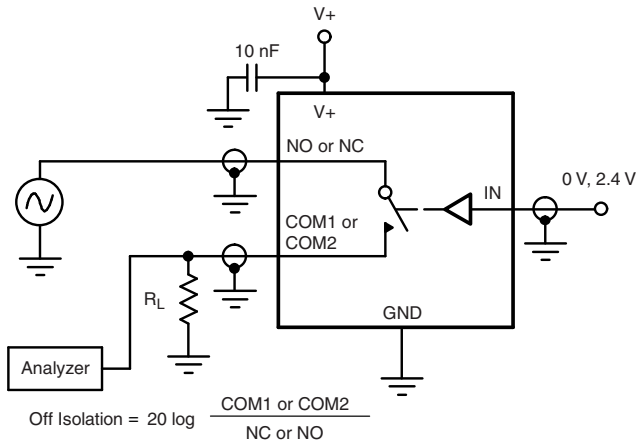

Fig. 4 - Off-Isolation

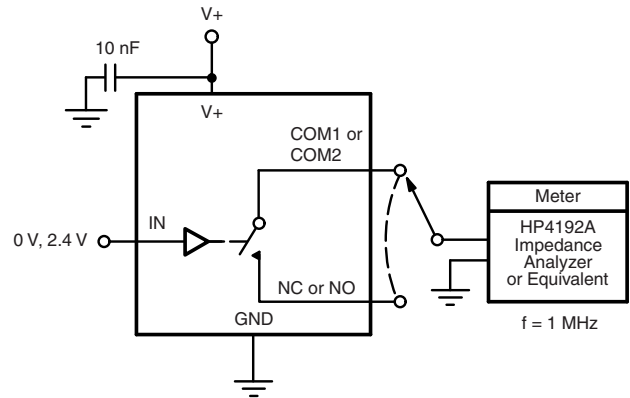
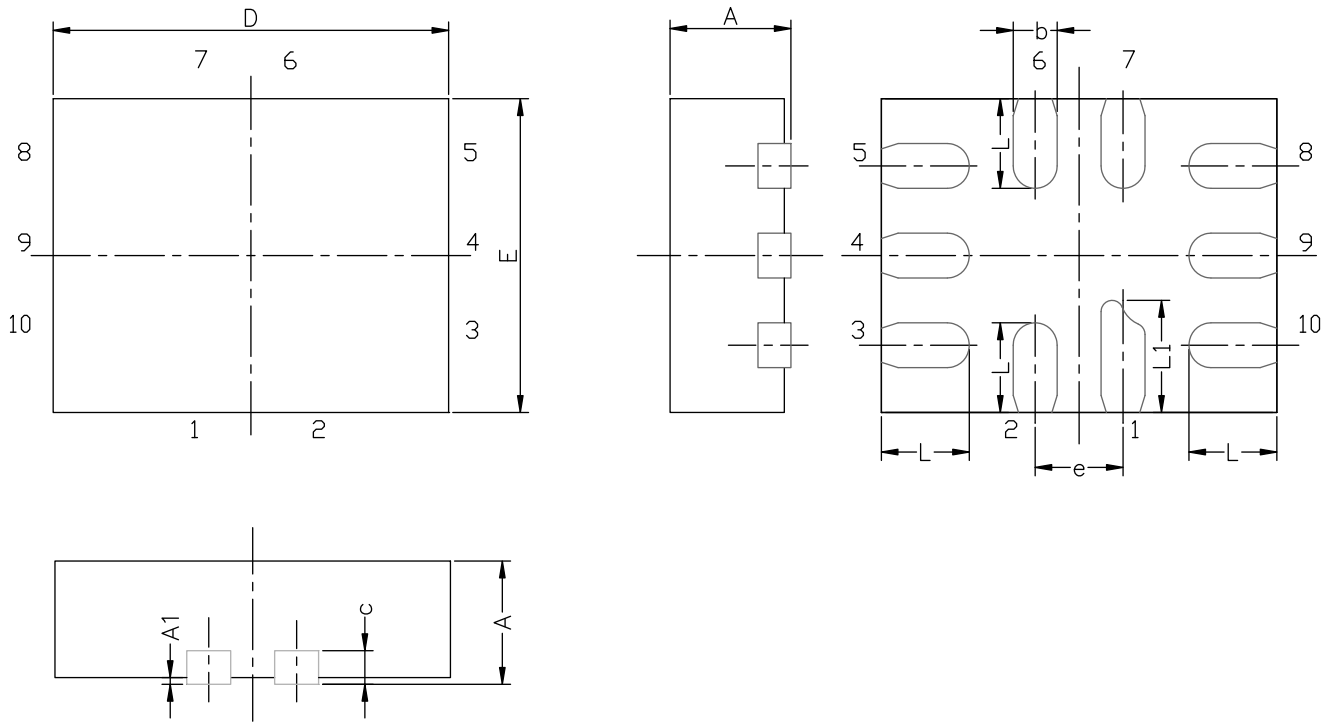

Fig. 5 - Channel Off/On Capacitance



PRODUCT SUMMARY	
Part number	DG2750
Status code	2
Configuration	SPDT x 2
Single supply min. (V)	1.6
Single supply max. (V)	5.5
Dual supply min. (V)	-
Dual supply max. (V)	-
On-resistance (Ω)	0.45
Charge injection (pC)	4
Source on capacitance (pF)	106
Source off capacitance (pF)	36
Leakage switch on typ. (nA)	50
Leakage switch off max. (nA)	250
-3 dB bandwidth (MHz)	49
Package	miniQFN-10
Functional circuit / applications	Audio, multi purpose, portable
Interface	Binary
Single supply operation	Yes
Dual supply operation	-
Turn on time max. (ns)	2100
Crosstalk and off isolation	-60

Vishay Siliconix maintains worldwide manufacturing capability. Products may be manufactured at one of several qualified locations. Reliability data for Silicon Technology and Package Reliability represent a composite of all qualified locations. For related documents such as package/tape drawings, part marking, and reliability data, see www.vishay.com/ppg?64736.

MINI QFN-10L CASE OUTLINE

DIM	MILLIMETERS			INCHES		
	MIN.	NAM.	MAX.	MIN.	NAM.	MAX.
A	0.45	0.55	0.60	0.0177	0.0217	0.0236
A1	0.00	-	0.05	0.000	-	0.002
b	0.15	0.20	0.25	0.006	0.008	0.010
c	0.150 or 0.127 REF ⁽¹⁾			0.006 or 0.005 REF ⁽¹⁾		
D	1.70	1.80	1.90	0.067	0.071	0.075
E	1.30	1.40	1.50	0.051	0.055	0.059
e	0.40 BSC			0.016 BSC		
L	0.35	0.40	0.45	0.014	0.016	0.018
L1	0.45	0.50	0.55	0.0177	0.0197	0.0217

Note

⁽¹⁾ The dimension depends on the leadframe that assembly house used.

ECN T16-0163-Rev. B, 16-May-16
DWG: 5957

Ultra Thin MiniQFN-10L-T0.35 Case Outline

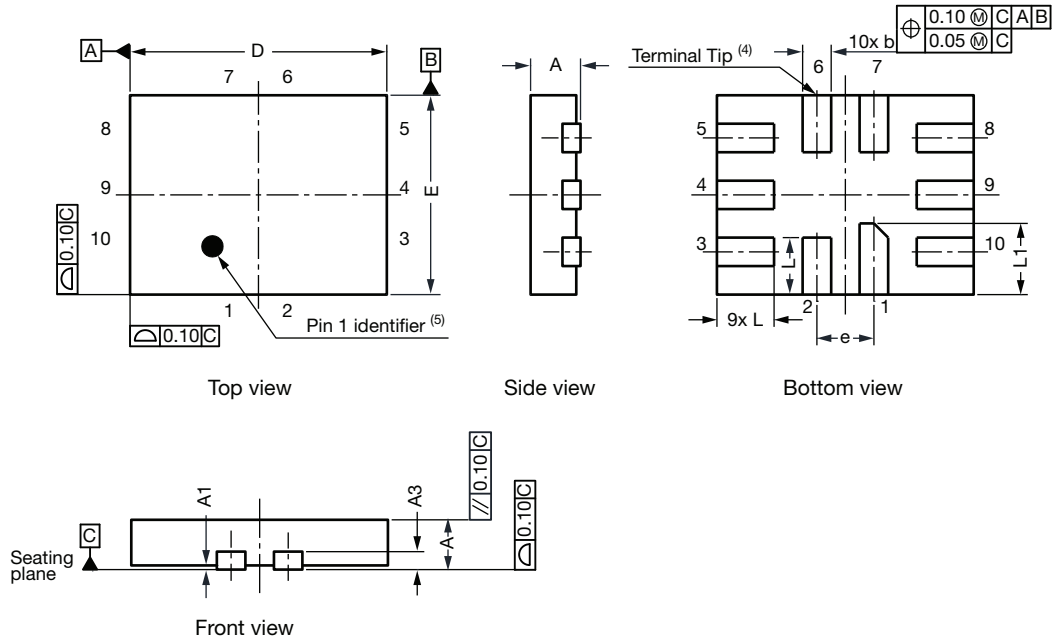

DIM.	MILLIMETERS			INCHES		
	MIN.	NOM.	MAX.	MIN.	NOM.	MAX.
A	0.30	0.35	0.40	0.012	0.014	0.016
A1	0.00	0.02	0.05	0.0000	0.0008	0.0020
A3	0.127 REF			0.005 REF		
b	0.15	0.20	0.25	0.006	0.008	0.010
D	1.80 BSC			0.071 BSC		
e	0.40 BSC			0.016 BSC		
E	1.40 BSC			0.055 BSC		
L	0.35	0.40	0.45	0.014	0.016	0.018
L1	0.45	0.50	0.55	0.018	0.020	0.022
N ⁽³⁾	10			10		
Nd ⁽³⁾	2			2		
Ne ⁽³⁾	3			3		
ECN: T15-0603-Rev. A, 12-Oct-15 DWG: 6045						

Notes

- (1) Use millimeters as the primary measurement.
- (2) Dimensioning and tolerances conform to ASME Y14.5M. - 1994.
- (3) N is the number of terminals, Nd is the number of terminals in X-direction, and Ne is the number of terminals in Y-direction.
- (4) Dimension b applies to plated terminal and is measured between 0.15 mm and 0.30 mm from terminal tip.
- (5) The pin #1 identifier must be existed on the top surface of the package by using indentation mark or other feature of package body.
- (6) Package warpage max. 0.05 mm.

RECOMMENDED MINIMUM PADS FOR MINI QFN 10L

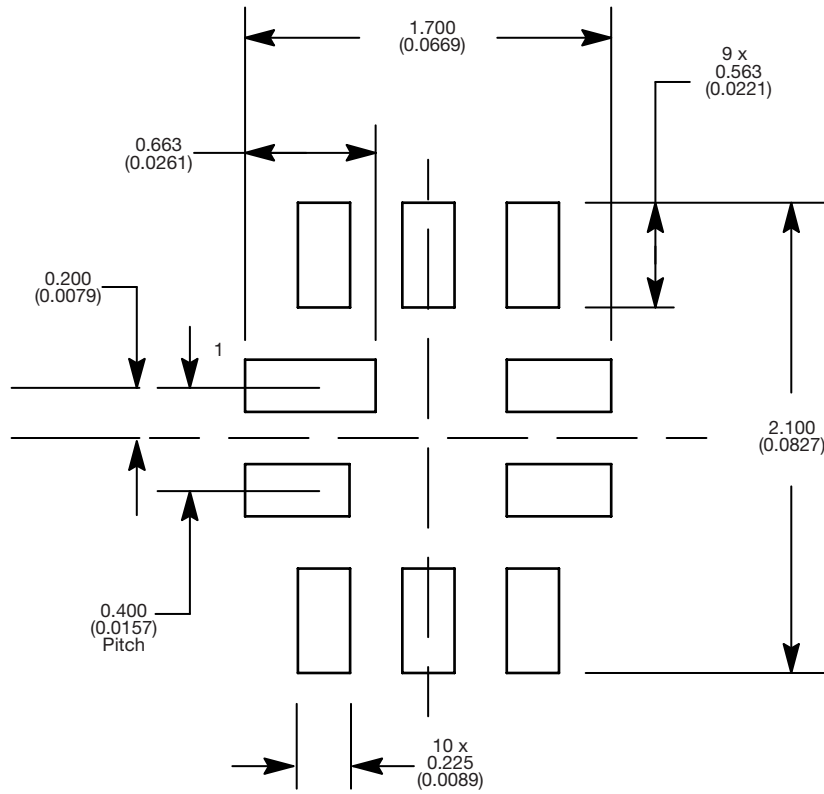

Mounting Footprint
Dimensions in mm (inch)



Disclaimer

ALL PRODUCT, PRODUCT SPECIFICATIONS AND DATA ARE SUBJECT TO CHANGE WITHOUT NOTICE TO IMPROVE RELIABILITY, FUNCTION OR DESIGN OR OTHERWISE.

Vishay Intertechnology, Inc., its affiliates, agents, and employees, and all persons acting on its or their behalf (collectively, "Vishay"), disclaim any and all liability for any errors, inaccuracies or incompleteness contained in any datasheet or in any other disclosure relating to any product.

Vishay makes no warranty, representation or guarantee regarding the suitability of the products for any particular purpose or the continuing production of any product. To the maximum extent permitted by applicable law, Vishay disclaims (i) any and all liability arising out of the application or use of any product, (ii) any and all liability, including without limitation special, consequential or incidental damages, and (iii) any and all implied warranties, including warranties of fitness for particular purpose, non-infringement and merchantability.

Statements regarding the suitability of products for certain types of applications are based on Vishay's knowledge of typical requirements that are often placed on Vishay products in generic applications. Such statements are not binding statements about the suitability of products for a particular application. It is the customer's responsibility to validate that a particular product with the properties described in the product specification is suitable for use in a particular application. Parameters provided in datasheets and / or specifications may vary in different applications and performance may vary over time. All operating parameters, including typical parameters, must be validated for each customer application by the customer's technical experts. Product specifications do not expand or otherwise modify Vishay's terms and conditions of purchase, including but not limited to the warranty expressed therein.

Hyperlinks included in this datasheet may direct users to third-party websites. These links are provided as a convenience and for informational purposes only. Inclusion of these hyperlinks does not constitute an endorsement or an approval by Vishay of any of the products, services or opinions of the corporation, organization or individual associated with the third-party website. Vishay disclaims any and all liability and bears no responsibility for the accuracy, legality or content of the third-party website or for that of subsequent links.

Vishay products are not designed for use in life-saving or life-sustaining applications or any application in which the failure of the Vishay product could result in personal injury or death unless specifically qualified in writing by Vishay. Customers using or selling Vishay products not expressly indicated for use in such applications do so at their own risk. Please contact authorized Vishay personnel to obtain written terms and conditions regarding products designed for such applications.

No license, express or implied, by estoppel or otherwise, to any intellectual property rights is granted by this document or by any conduct of Vishay. Product names and markings noted herein may be trademarks of their respective owners.