

> 500 MHz, - 3 dB Bandwidth; Dual SPDT Analog Switch

DESCRIPTION

DG2721 is a low R_{on} , high bandwidth analog switch configured in dual SPDT.

It achieves 5.7Ω switch on resistance, greater than 500 MHz - 3 dB bandwidth with 5 pF load, and a channel to channel crosstalk and Isolation at - 49 dB.

Fabricated with high density sub micro CMOS process, the DG2721 provides low parasitic capacitance, handles bidirectional signal flow with minimized phase distortion. Guaranteed 1.3 V logic high threshold makes it possible to interface directly with low voltage MCUs.

The DG2721 is designed for a wide range of operating voltages from 2.7 V to 4.3 V that can be driven directly from one cell Li-ion battery. On-chip protection circuit protects against fault events when signals at "com" pins goes beyond $V+$.

Latch up current is greater than 300 mA, as per JESD78, and its ESD tolerance exceeds 8 kV.

Packaged in ultra small miniQFN-10 (1.4 mm x 1.8 mm x 0.55 mm), it is ideal for portable high speed mix signal switching application.

As a committed partner to the community and the environment, Vishay Siliconix manufactures this product with lead (Pb)-free device termination. The miniQFN-10 package has a nickel-palladium-gold device termination and is represented by the lead (Pb)-free "-E4" suffix to the ordering part number. The nickel-palladium-gold device terminations meet all JEDEC standards for reflow and MSL rating.

As a further sign of Vishay Siliconix's commitment, the DG2721 is fully RoHS compliant.

FEATURES

- Wide operation voltage range
- Low on-resistance, 5.7Ω (typical at 3 V)
- Low capacitance, 5.6 pF (typical)
- - 3 dB high bandwidth with 5 pF load: > 500 MHz (typical)
- Low bit to bit skew: 40 pS (typical)
- Low power consumption
- Low logic threshold: V
- Power down protection: COM_1 and COM_2 pins can tolerate up to 5 V when $V+ = 0$ V
- Logic (IN_1 and IN_2) above $V+$ tolerance
- Latch-up current greater than 300 mA per JESD78
- 8 kV ESD protection (HBM)
- Lead (Pb)-free low profile miniQFN-10 (1.4 mm x 1.8 mm x 0.55 mm)



RoHS
COMPLIANT

APPLICATIONS

- Cellular phones
- Portable media players
- PDA
- Digital camera
- GPS
- Notebook computer
- TV, monitor, and set top box
- Radio

FUNCTIONAL BLOCK DIAGRAM AND PIN CONFIGURATION

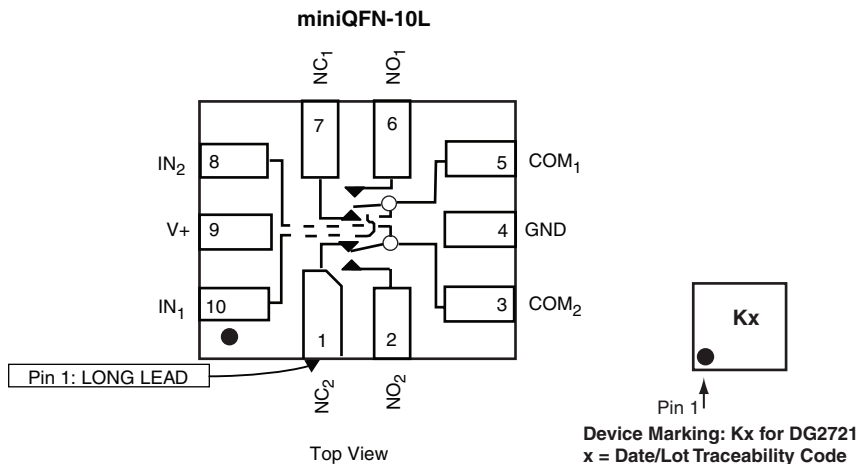



ORDERING INFORMATION		
Temp. Range	Package	Part Number
- 40 °C to 85 °C	miniQFN-10	DG2721DN-T1-E4

TRUTH TABLE		
IN ₁ (Pin 10)	IN ₂ (Pin 8)	Function
X	0	COM2 = NC ₂
X	1	COM2 = NO ₂
0	X	COM1 = NC ₁
1	X	COM1 = NO ₁

PIN DESCRIPTIONS	
Pin Name	Description
IN ₁	Select Input COM ₁
IN ₂	Select Input COM ₂
NC _{1/2} , NO _{1/2} , COM _{1/2}	Data Channel

ABSOLUTE MAXIMUM RATINGS T _A = 25 °C, unless otherwise noted			
Parameter		Limit	Unit
Reference to GND	V+	- 0.3 to 5.5	V
	IN _x , NC _x , NO _x , COM _x ^a	- 0.3 to (V+ + 0.3)	
Current (Any Terminal except IN _x , NC _x , NO _x , COM _x)		30	mA
Continuous Current (IN _x , NC _x , NO _x , COM _x)		± 250	
Peak Current (Pulsed at 1 ms, 10 % duty cycle)		± 500	
Storage Temperature (D Suffix)		- 65 to 150	°C
Power Dissipation (Packages) ^b	miniQFN-10 ^c	208	mW
ESD (Human Body Model)			
All Pins		4	kV
I/O to GND		8	
Latch-up (Current Injection)		350	mA

Notes:

- a. Signals on IN_x, NC_x, NO_x, COM_x exceeding V+ will be clamped by internal diodes. Limit forward diode current to maximum current ratings.
- b. All leads welded or soldered to PC board.
- c. Derate 2.6 mW/°C above 70 °C.



SPECIFICATIONS $V_+ = 3.0\text{ V}$								
Parameter	Symbol	Test Conditions Otherwise Unless Specified	Temp. ^a	Limits - 40 °C to 85 °C			Unit	
				Min. ^b	Typ. ^c	Max. ^b		
Analog Switch								
Analog Signal Range ^d	V_{ANALOG}	$R_{DS(on)}$	Full	0		V_+	V	
On-Resistance	$R_{DS(on)}$	$V_+ = 3.0\text{ V}, I_{COM} = 8\text{ mA}, V_{NC/NO} = 0.4\text{ V}$	Room		5.7	7	Ω	
			Full			9		
On-Resistance Match ^d	ΔR_{ON}	$V_+ = 3.0\text{ V}, I_{COM} = 8\text{ mA}, V_{NC/NO} = 0.4\text{ V}$	Room		0.35			
On-Resistance Resistance Flatness ^d	R_{ON} Flatness	$V_+ = 3.0\text{ V}, I_{COM} = 8\text{ mA}, V_{NC/NO} = 0.0\text{ V}, 1.0\text{ V}$	Room		2			
Switch Off Leakage Current	$I_{(off)}$	$V_+ = 4.3\text{ V}, V_{NC/NO} = 0.3\text{ V}, 3.0\text{ V},$ $V_{COM} = 3.0\text{ V}, 0.3\text{ V}$	Full	- 100		100	nA	
Channel On Leakage Current	$I_{(on)}$	$V_+ = 4.3\text{ V}, V_{NC/NO} = 0.3\text{ V}, 4.0\text{ V},$ $V_{COM} = 4.0\text{ V}, 0.3\text{ V}$	Full	- 200		200		
Digital Control								
Input Voltage High	V_{INH}	$V_+ = 3.0\text{ V to } 3.6\text{ V}$	Full	1.3			V	
		$V_+ = 4.3\text{ V}$	Full	1.7				
Input Voltage Low	V_{INL}	$V_+ = 3.0\text{ V to } 4.3\text{ V}$	Full			0.5		
Input Capacitance	C_{IN}		Full		5.6		pF	
Input Current	I_{INL} or I_{INH}	$V_{IN} = 0$ or V_+	Full	- 1		1	μA	
Dynamic Characteristics								
Break-Before-Make Time ^{e, d}	t_{BBM}	$V_+ = 3.0\text{ V}, V_{COM} = 1.5\text{ V}, R_L = 50\ \Omega,$ $C_L = 35\text{ pF}$	Room		5		ns	
			Full					
Turn-On Time ^{e, d}	t_{ON}		Room			30		
			Full					
Turn-Off Time ^{e, d}	t_{OFF}		Room			25		
			Full					
Charge Injection ^d	Q_{INJ}	$C_L = 1\text{ nF}, R_{GEN} = 0\ \Omega, V_{GEN} = 0\text{ V}$	Room		0.5		pC	
Off-Isolation ^d	OIRR	$V_+ = 3.0\text{ V to } 3.6\text{ V}, R_L = 50\ \Omega, C_L = 5\text{ pF},$ $f = 240\text{ MHz}$			- 30		dB	
Crosstalk ^d	X_{TALK}				- 49			
Bandwidth ^d	BW	$V_+ = 3.0\text{ V to } 3.6\text{ V}, R_L = 50\ \Omega,$ $C_L = 5\text{ pF}, - 3\text{ dB}$				> 500		MHz
Channel-Off Capacitance ^d	$C_{NO(off)}$	$V_+ = 3.3\text{ V}, f = 1\text{ MHz}$				4		pF
	$C_{NC(off)}$					4		
Channel-On Capacitance ^d	$C_{COM(on)}$						11	
Channel-to-Channel Skew ^d	$t_{SK(O)}$					50		
Skew Off Opposite Transitions of the Same Output ^d	$t_{SK(p)}$	$V_+ = 3.0\text{ V to } 3.6\text{ V}, R_L = 50\ \Omega, C_L = 5\text{ pF}$			20		ps	
Total Jitter ^d	t_J				200			
Power Supply								
Power Supply Range	V_+			2.6		4.3	V	
Power Supply Current	I_+	$V_{IN} = 0\text{ V}, \text{ or } V_+$	Full			2	μA	

Notes:

- a. Room = 25 °C, Full = as determined by the operating suffix.
- b. The algebraic convention whereby the most negative value is a minimum and the most positive a maximum, is used in this data sheet.
- c. Typical values are for design aid only, not guaranteed nor subject to production testing.
- d. Guarantee by design, not subjected to production test.
- e. V_{IN} = input voltage to perform proper function.
- f. Crosstalk measured between channels.

Stresses beyond those listed under "Absolute Maximum Ratings" may cause permanent damage to the device. These are stress ratings only, and functional operation of the device at these or any other conditions beyond those indicated in the operational sections of the specifications is not implied. Exposure to absolute maximum rating conditions for extended periods may affect device reliability.

TYPICAL CHARACTERISTICS $T_A = 25\text{ }^\circ\text{C}$, unless otherwise noted

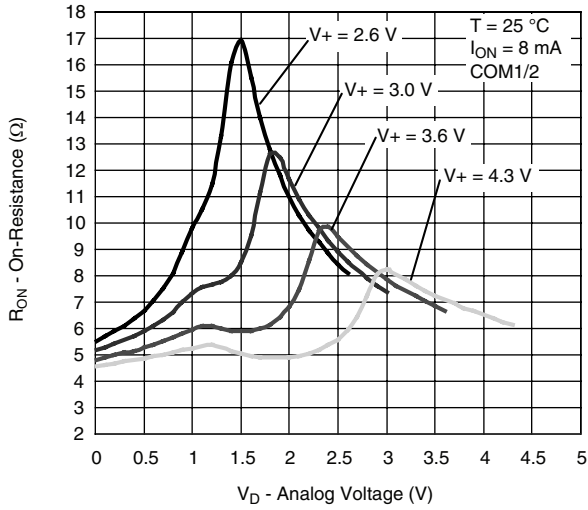

On-Resistance vs. V_D and Single Supply Voltage

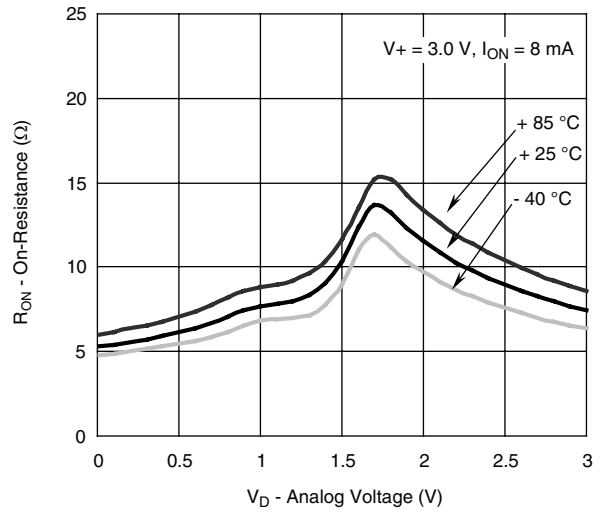

On-Resistance vs. Analog Voltage and Temperature

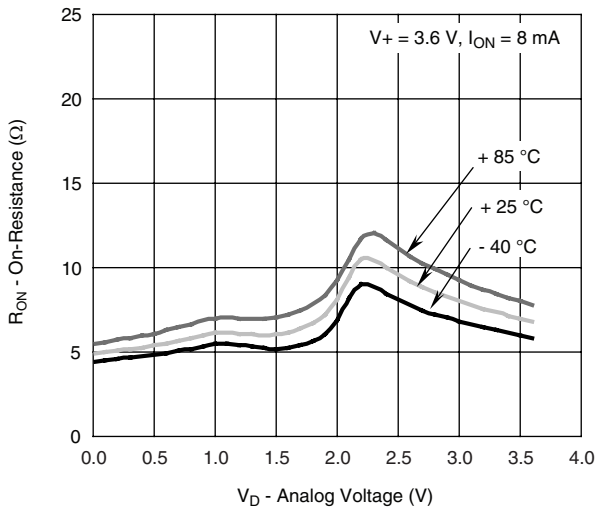

On-Resistance vs. Analog Voltage and Temperature

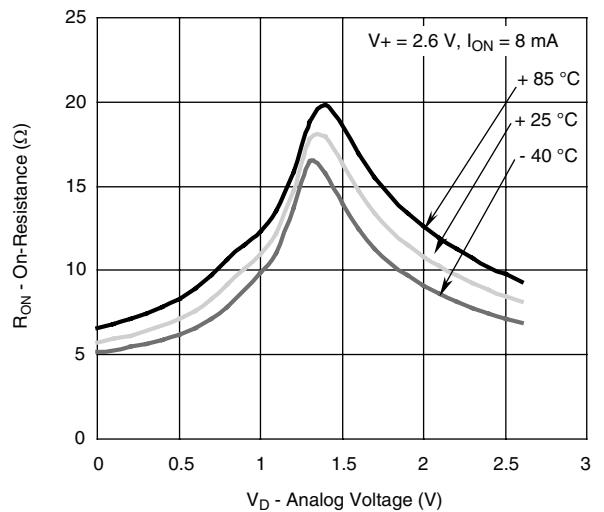

On-Resistance vs. Analog Voltage and Temperature

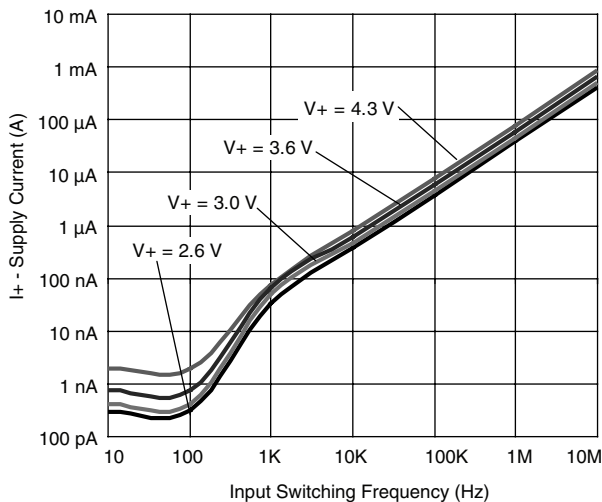

Supply Current vs. Input Switching Frequency

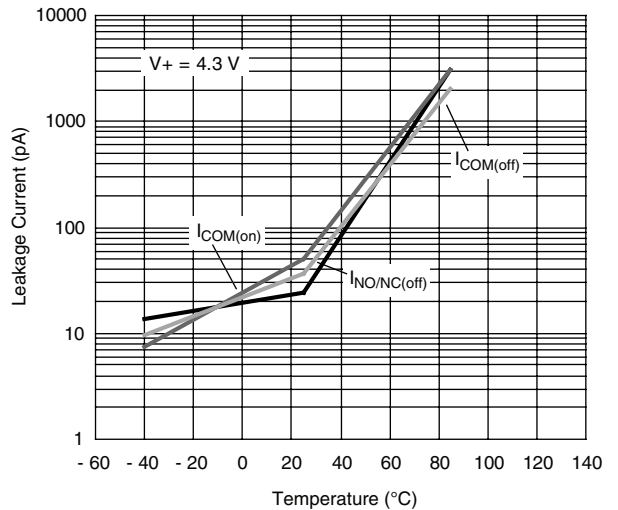

Leakage Current vs. Temperature

TYPICAL CHARACTERISTICS $T_A = 25\text{ }^\circ\text{C}$, unless otherwise noted

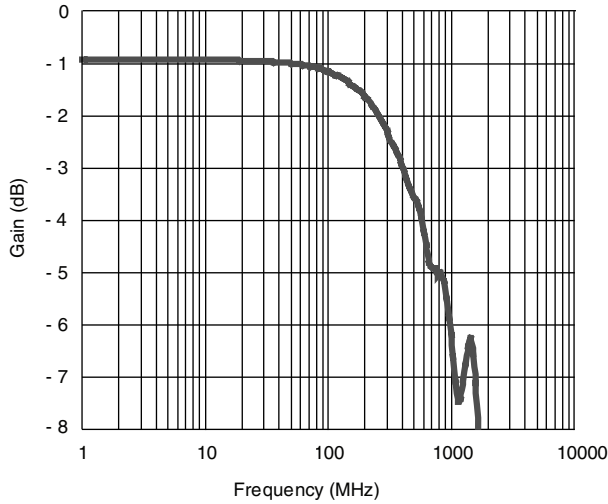

Gain vs. Frequency, $C_L = 5\text{ pF}$, $V_+ = 3.3\text{ V}$

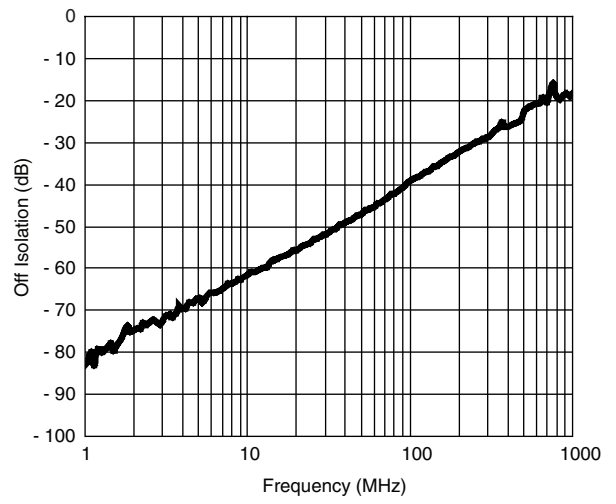

Off Isolation, $V_+ = 3.3\text{ V}$

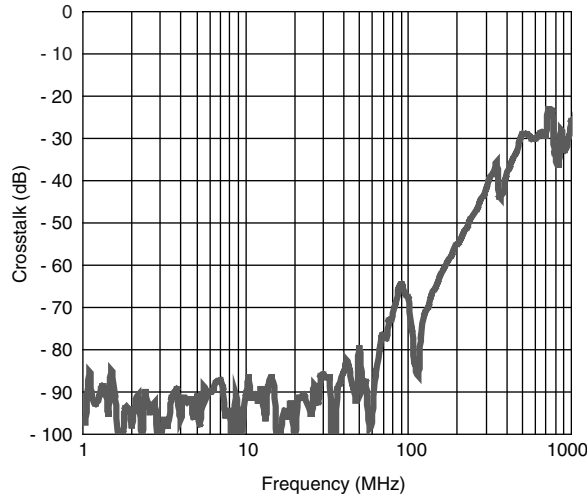

Crosstalk, $V_+ = 3.3\text{ V}$

TEST CIRCUITS

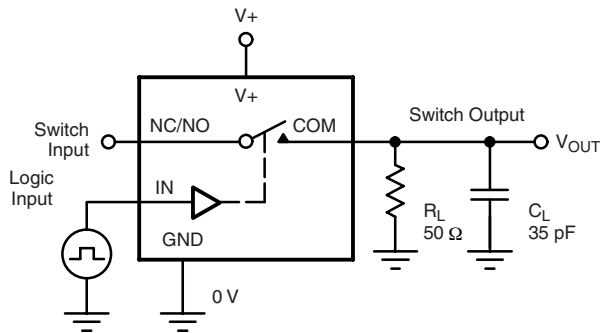

C_L (includes fixture and stray capacitance)

$$V_{OUT} = V_{COM} \left(\frac{R_L}{R_L + R_{ON}} \right)$$

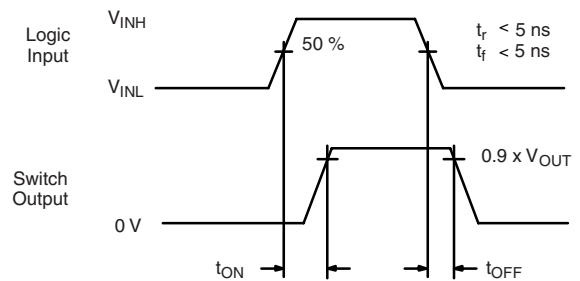

Logic "1" = Switch On
Logic input waveforms inverted for switches that have the opposite logic sense.

Figure 1. Switching Time

TEST CIRCUITS

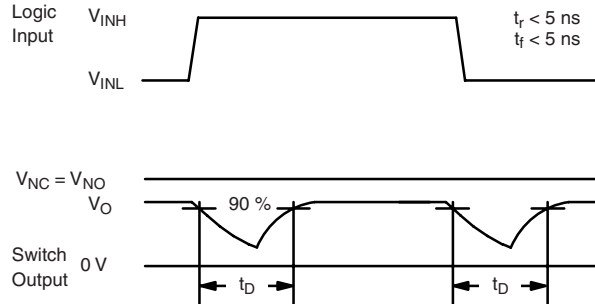
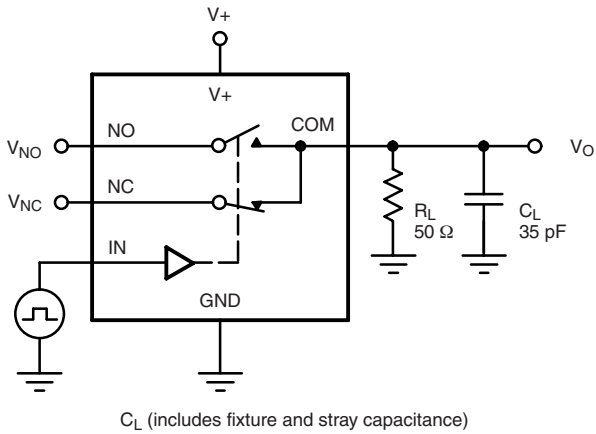
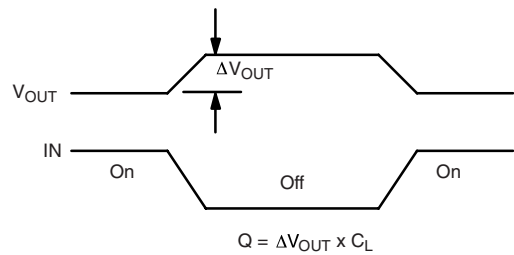
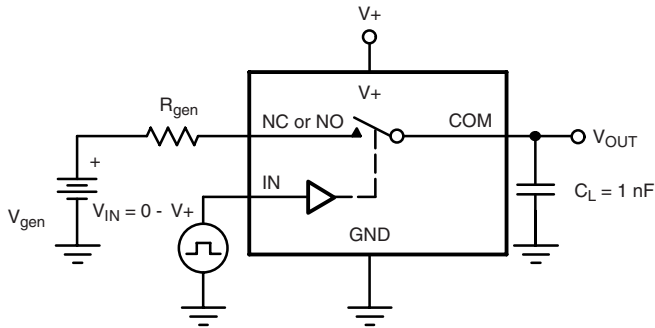

Figure 2. Break-Before-Make Interval



IN depends on switch configuration: input polarity determined by sense of switch.

Figure 3. Charge Injection

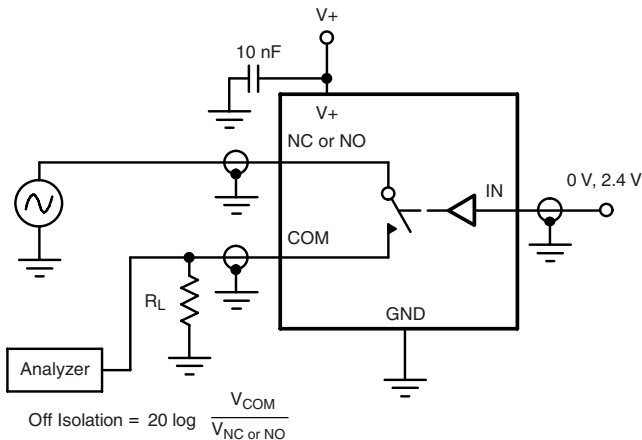

Figure 4. Off-Isolation

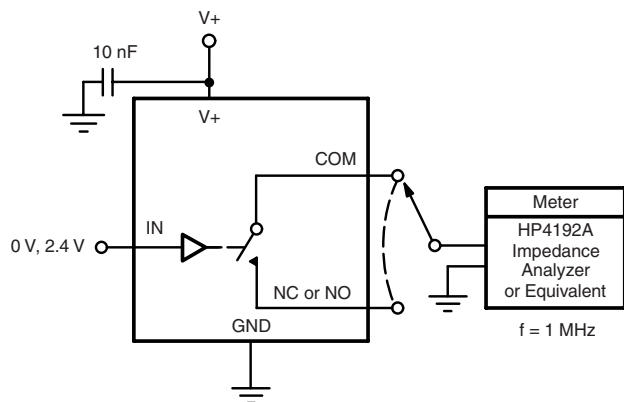
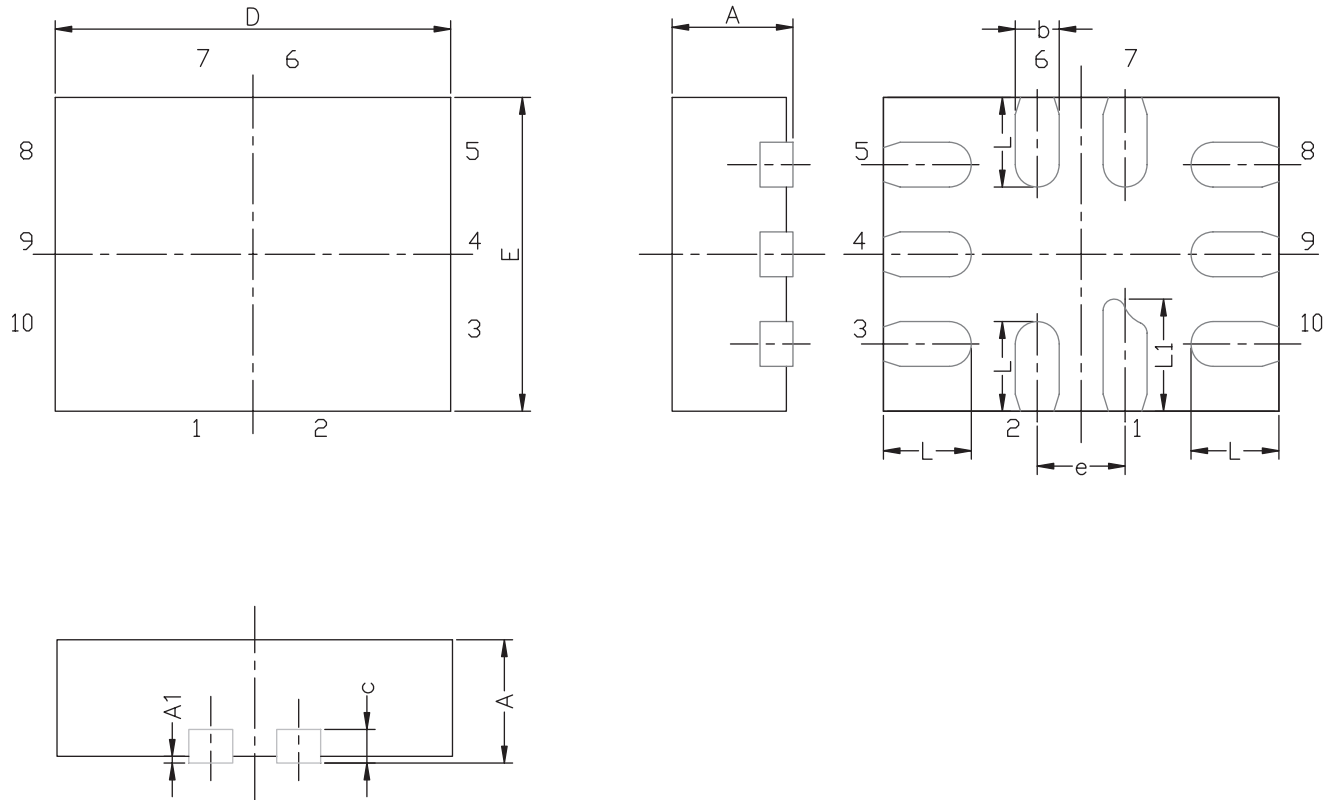

Figure 5. Channel Off/On Capacitance

Vishay Siliconix maintains worldwide manufacturing capability. Products may be manufactured at one of several qualified locations. Reliability data for Silicon Technology and Package Reliability represent a composite of all qualified locations. For related documents such as package/tape drawings, part marking, and reliability data, see www.vishay.com/ppg?69950.

MINI QFN-10L CASE OUTLINE



DIM	MILLIMETERS			INCHES		
	MIN.	NAM.	MAX.	MIN.	NAM.	MAX.
A	0.50	0.55	0.60	0.0197	0.0217	0.0236
A1	0.00	-	0.05	0.000	-	0.002
b	0.15	0.20	0.25	0.006	0.008	0.010
c	0.15 REF			0.006 REF		
D	1.75	1.80	1.85	0.069	0.071	0.073
E	1.35	1.40	1.45	0.053	0.055	0.057
e	0.40 BSC			0.016 BSC		
L	0.35	0.40	0.45	0.014	0.016	0.018
L1	0.45	0.50	0.55	0.0177	0.0197	0.0217

ECN T-07039-Rev. A, 12-Feb-07
DWG: 5957



Disclaimer

ALL PRODUCT, PRODUCT SPECIFICATIONS AND DATA ARE SUBJECT TO CHANGE WITHOUT NOTICE TO IMPROVE RELIABILITY, FUNCTION OR DESIGN OR OTHERWISE.

Vishay Intertechnology, Inc., its affiliates, agents, and employees, and all persons acting on its or their behalf (collectively, "Vishay"), disclaim any and all liability for any errors, inaccuracies or incompleteness contained in any datasheet or in any other disclosure relating to any product.

Vishay makes no warranty, representation or guarantee regarding the suitability of the products for any particular purpose or the continuing production of any product. To the maximum extent permitted by applicable law, Vishay disclaims (i) any and all liability arising out of the application or use of any product, (ii) any and all liability, including without limitation special, consequential or incidental damages, and (iii) any and all implied warranties, including warranties of fitness for particular purpose, non-infringement and merchantability.

Statements regarding the suitability of products for certain types of applications are based on Vishay's knowledge of typical requirements that are often placed on Vishay products in generic applications. Such statements are not binding statements about the suitability of products for a particular application. It is the customer's responsibility to validate that a particular product with the properties described in the product specification is suitable for use in a particular application. Parameters provided in datasheets and/or specifications may vary in different applications and performance may vary over time. All operating parameters, including typical parameters, must be validated for each customer application by the customer's technical experts. Product specifications do not expand or otherwise modify Vishay's terms and conditions of purchase, including but not limited to the warranty expressed therein.

Except as expressly indicated in writing, Vishay products are not designed for use in medical, life-saving, or life-sustaining applications or for any other application in which the failure of the Vishay product could result in personal injury or death. Customers using or selling Vishay products not expressly indicated for use in such applications do so at their own risk and agree to fully indemnify and hold Vishay and its distributors harmless from and against any and all claims, liabilities, expenses and damages arising or resulting in connection with such use or sale, including attorneys fees, even if such claim alleges that Vishay or its distributor was negligent regarding the design or manufacture of the part. Please contact authorized Vishay personnel to obtain written terms and conditions regarding products designed for such applications.

No license, express or implied, by estoppel or otherwise, to any intellectual property rights is granted by this document or by any conduct of Vishay. Product names and markings noted herein may be trademarks of their respective owners.

Material Category Policy

Vishay Intertechnology, Inc. hereby certifies that all its products that are identified as RoHS-Compliant fulfill the definitions and restrictions defined under Directive 2011/65/EU of The European Parliament and of the Council of June 8, 2011 on the restriction of the use of certain hazardous substances in electrical and electronic equipment (EEE) - recast, unless otherwise specified as non-compliant.

Please note that some Vishay documentation may still make reference to RoHS Directive 2002/95/EC. We confirm that all the products identified as being compliant to Directive 2002/95/EC conform to Directive 2011/65/EU.