

SMBus Multi-Output Power-Supply Controller

FEATURES

- Up to 95% Efficiency
- 3% Total Regulation (Each Controller)
- 5.5-V to 30-V Input Voltage Range
- 3.3-V, 5-V, and 12-V Outputs
- 200-kHz/300-kHz Low-Noise Frequency Operation
- Precision 3.3-V Reference Output
- 30 mA Linear Regulator Output
- SMBUS Interface
- High Efficiency Pulse Skipping Mode Operation at Light Load
- Only Three Inductors Required – No Transformer
- LITTLE FOOT® Optimized Output Drivers
- Internal Soft-Start
- Synchronizable
- Minimal External Control Components
- 28-Pin SSOP Package

DESCRIPTION

The Si9135 is a current-mode PWM and PSM converter controller, with two synchronous buck converters (3.3 V and 5 V) and a flyback (non-isolated buck-boost) converter (12 V). Designed for portable devices, it offers a total five power outputs (three tightly regulated dc/dc converter outputs, a precision 3.3-V reference and a 5-V LDO output). It requires minimum external components and is capable of achieving conversion efficiencies approaching 95%.

Along with the SMBUS interface, the Si9135 provides programmable output selection capability.

The Si9135 is available in both standard and lead (Pb)-free 28-pin SSOP packages and specified to operate over the extended commercial (0°C to 90°C) temperature range.

FUNCTIONAL BLOCK DIAGRAM

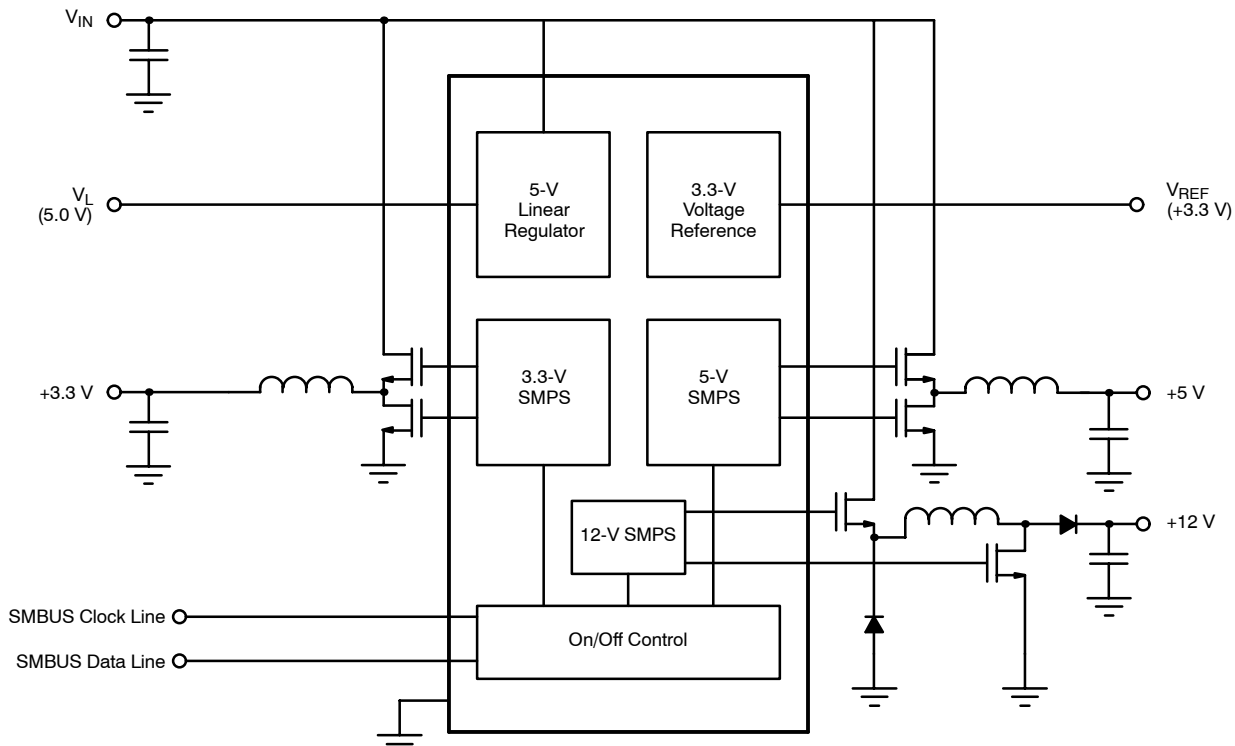

ABSOLUTE MAXIMUM RATINGS

V_{IN} to GND	-0.3 to +36 V
P_{GND} to GND	± 2 V
V_L to GND	-0.3 to +6.5 V
BST ₃ , BST ₅ , BSTFY to GND	-0.3 V to +36 V
V_L Short to GND	Continuous
LX ₃ to BST ₃ ; LX ₅ to BST ₅ ; LXFY to BST	-6.5 V to 0.3 V
Inputs/Outputs to GND (SYNC, CS ₃ , CS ₅ , CSP, CSN)	-0.3 V to (V_L +0.3 V)
SDA, SCL	-0.3 V to +5.5 V
DL3, DL5, DLFY to PGND	-0.3 V to (V_L +0.3 V)

DH3 to LX ₃ , DH5 to LX ₅ , DHFY to LXFY	-0.3 V to (BSTX +0.3 V)
Continuous Power Dissipation ($T_A = 90^\circ\text{C}$) ^a	
28-Pin SSOP ^b	572 mW
Operating Temperature Range	0°C to 90°C
Storage Temperature Range	-40°C to 125°C
Lead Temperature (Soldering, 10 Sec.)	300°C

Notes

- Device mounted with all leads soldered or welded to PC board.
- Derate 9.52 mW/°C above 90°C.

Stresses beyond those listed under "Absolute Maximum Ratings" may cause permanent damage to the device. These are stress ratings only, and functional operation of the device at these or any other conditions beyond those indicated in the operational sections of the specifications is not implied. Exposure to absolute maximum rating conditions for extended periods may affect device reliability.

SPECIFICATIONS					
Parameter	Specific Test Conditions $V_{IN} = 15\text{ V}$, $I_{VL} = I_{REF} = 0\text{ mA}$ $T_A = 0^\circ\text{C}$ to 90°C , All Converters ON	Limits			Unit
		Min ^a	Typ ^b	Max ^a	
3.3-V Buck Controller					
Total Regulation (Line, Load, and Temperature)	$V_{IN} = 6$ to 30 V, $0 < V_{CS3} - V_{FB3} < 90\text{ mV}$	3.23	3.33	3.43	V
Line Regulation	$V_{IN} = 6$ to 30 V			± 0.5	%
Load Regulation	$0 < V_{CS3} - V_{FB3} < 90\text{ mV}$			± 0.5	
Current Limit	$V_{CS3} - V_{FB3}$	90	125	160	mV
Bandwidth	$L = 10\ \mu\text{H}$, $C = 330\ \mu\text{F}$		50		kHz
Phase Margin	$R_{SENSE} = 20\ \text{m}\Omega$		65		°
5-V Buck Controller					
Total Regulation (Line, Load, and Temperature)	$V_{IN} = 6$ to 30 V, $0 < V_{CS5} - V_{FB5} < 90\text{ mV}$	4.88	5.03	5.18	V
Line Regulation	$V_{IN} = 6$ to 30 V			± 0.5	%
Load Regulation	$0 < V_{CS5} - V_{FB5} < 90\text{ mV}$			± 0.5	
Current Limit	$V_{CS5} - V_{FB5}$	90	125	160	mV
Bandwidth	$L = 10\ \mu\text{H}$, $C = 330\ \mu\text{F}$		50		kHz
Phase Margin	$R_{SENSE} = 20\ \text{m}\Omega$		65		°
12-V Flyback Controller					
Total Regulation (Line, Load, and Temperature)	$V_{IN} = 6$ to 30 V, $0 < V_{CSP} - V_{CSN} < 300\text{ mV}$	11.4	12.0	12.6	V
Line Regulation	$V_{IN} = 6$ to 30 V			± 0.5	%
Load Regulation	$0 < V_{CSP} - V_{FBN} < 300\text{ mV}$			± 0.5	
Current Limit	$V_{CSP} - V_{CSN}$	330	410	500	mV
Bandwidth	$L = 10\ \mu\text{H}$, $C = 100\ \mu\text{F}$		10		kHz
Phase Margin	$R_{SENSE} = 100\ \text{m}\Omega$, $C_{comp} = 120\ \text{pF}$		65		°
Internal Regulator					
V_L Output	All Converters OFF, $V_{IN} > 5.5\text{ V}$, $0 < I_L < 30\text{ mA}$	4.7		5.5	V
V_L Fault Lockout Voltage		3.6		4.2	
V_L Fault Lockout Hysteresis			75		mV
V_L /FB5 Switchover Voltage		4.2		4.7	V
V_L /FB5 Switchover Hysteresis			75		mV



SPECIFICATIONS					
Parameter	Specific Test Conditions $V_{IN} = 15\text{ V}$, $I_{VL} = I_{REF} = 0\text{ mA}$ $T_A = 0^\circ\text{C}$ to 90°C , All Converters ON	Limits			Unit
		Min ^a	Typ ^b	Max ^a	
Reference					
REF Output	No External Load	3.24	3.30	3.36	V
REF Load Regulation	0 to 1 mA		30	75	mV
Supply Current					
Supply Current – Shutdown	All Converters OFF, No Load		35	60	μA
Supply Current – Operation	All Converters ON, No Load, $F_{OCS} = 200\text{ kHz}$		1100	1800	
Oscillator					
Oscillator Frequency	SYNC tied to REF	270	300	330	kHz
	SYNC tied to GND or V_L	180	200	220	
SYNC High-Pulse Width		200			nsec
SYNC Low-Pulse Width		200			
SYNC Rise/Fall Range				200	
SYNC V_{IL}				0.8	V
SYNC V_{IH}		$V_L - 0.5$			
Oscillator SYNC Range		250		400	kHz
Maximum Duty Cycle	SYNC tied to GND or V_L	92	95		%
	SYNC tied to REF	89	92		
Outputs					
Gate Driver Sink/Source Current (Buck)	DL3, DH3, DL5, DH5 Forced to 2 V		1		A
Gate Driver On-Resistance (Buck)	High or Low		2	7	Ω
Gate Driver Sink/Source Current (Flyback)	DHFY, DLFY Forced to 2 V		0.2		A
Gate Driver On-Resistance (Flyback)	High or Low			15	Ω
SCL, SDA					
V_{IL}				0.6	V
V_{IH}		1.4			

Notes

- a. The algebraic convention whereby the most negative value is a minimum and the most positive a maximum.
- b. Typical values are for DESIGN AID ONLY, not guaranteed nor subject to production testing.

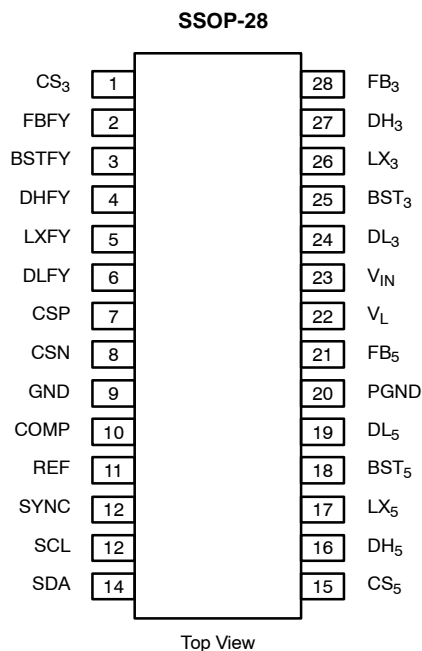
PIN CONFIGURATION

ORDERING INFORMATION

Part Number	Lead (Pb)-Free Part Number	Temperature Range	V _{OUT}
Si9135LG		0 to 90°C	3.3 V, 5 V, 12 V
Si9135LG-T1	Si9135LG-T1—E3		

PIN DESCRIPTION

Pin Number	Symbol	Description
1	CS ₃	Current sense input for 3.3-V buck.
2	FBFY	Feedback for flyback.
3	BSTFY	Boost capacitor connection for flyback converter.
4	DHfy	Gate-drive output for flyback high-side MOSFET.
5	LXfy	Inductor connection for flyback converter.
6	DLfy	Gate-drive output for flyback low-side MOSFET.
7	CSP	Current sense positive input for flyback converter.
8	CSN	Current sense negative input for flyback converter.
9	GND	Analog ground.
10	COMP	Flyback compensation connection, if required.
11	REF	3.3-V internal reference.
12	SYNC	Oscillator synchronization inputs.
13	SCL	SMBUS clock line.
14	SDA	SMBUS data line.
15	CS ₅	Current sense input for 5-V buck controller.
16	DH5	Inductor connection for buck 5-V.
17	LX ₅	Gate-drive output for 5-V buck high-side MOSFET.
18	BST ₅	Boost capacitor connection for 5-V buck converter.
19	DL ₅	Gate-drive output for 5-V buck low-side MOSFET.
20	PGND	Power ground.
21	FB ₅	Feedback for 5-V buck.
22	V _L	5-V logic supply voltage for internal circuitry.
23	V _{IN}	Input voltage
24	DL ₃	Gate-drive output for 3.3-V buck low-side MOSFET.
25	BST ₃	Boost capacitor connection for 3.3-V buck converter.
26	LX ₃	Inductor connection for 3.3-V buck low-side MOSFET.
27	DH ₃	Gate-drive output for 3.3-V buck high-side MOSFET.
28	FB ₃	Feedback for 3.3-V buck.



TYPICAL CHARACTERISTICS (25°C UNLESS OTHERWISE NOTED)

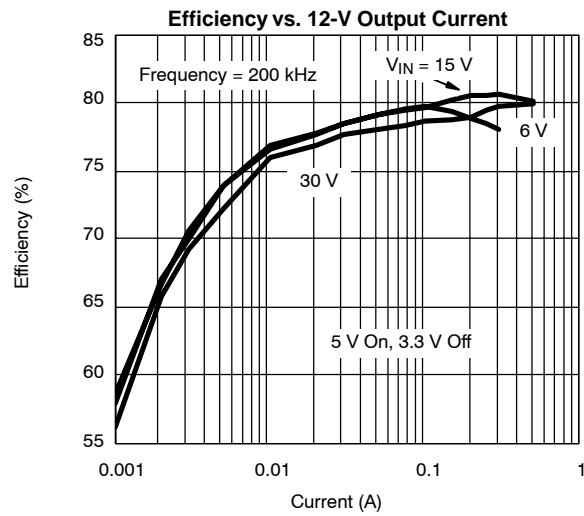
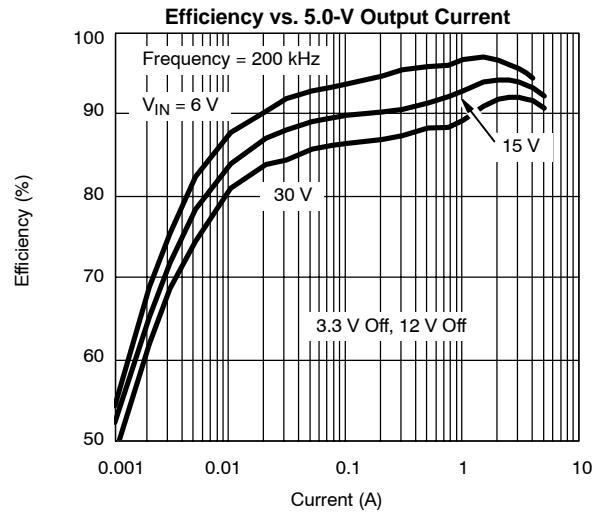
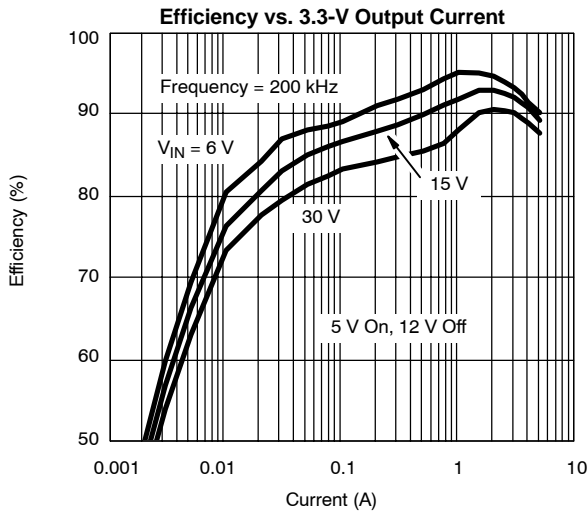

TYPICAL WAVEFORMS

5-V Converter ($V_{IN} = 10\text{ V}$)

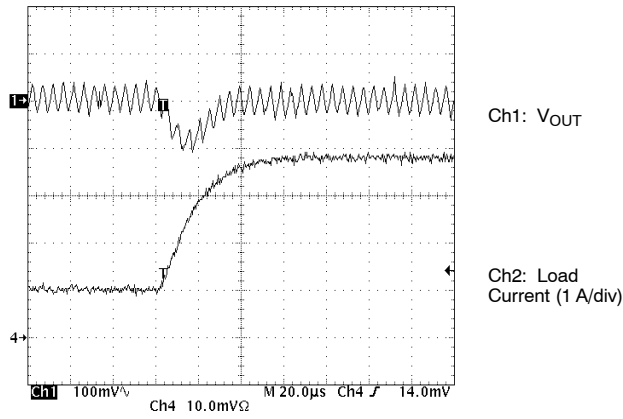

PWM Loading

5-V Converter ($V_{IN} = 10\text{ V}$)

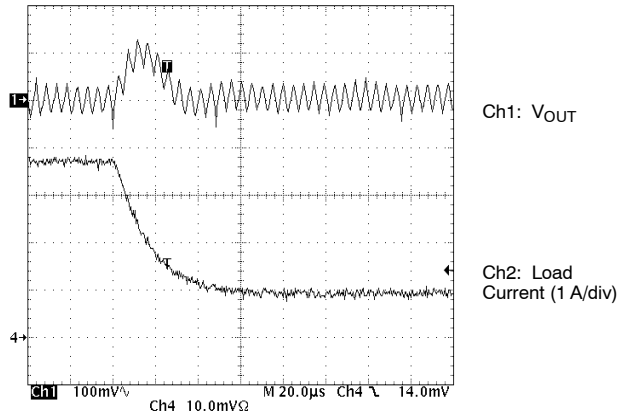

PWM Unloading

5-V Converter ($V_{IN} = 10\text{ V}$)

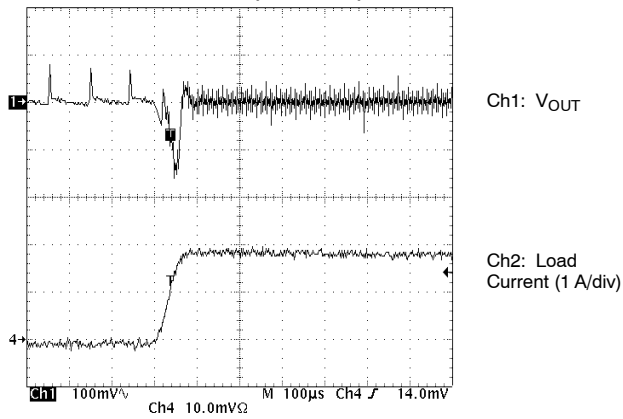

PSM to PWM

5-V Converter ($V_{IN} = 10\text{ V}$)

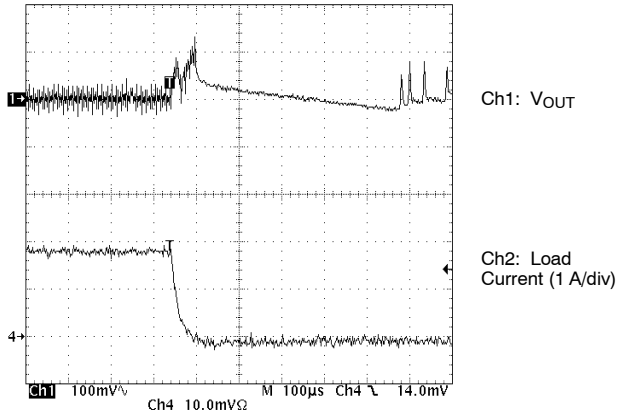

PWM to PSM

5-V Converter ($V_{IN} = 10\text{ V}$)

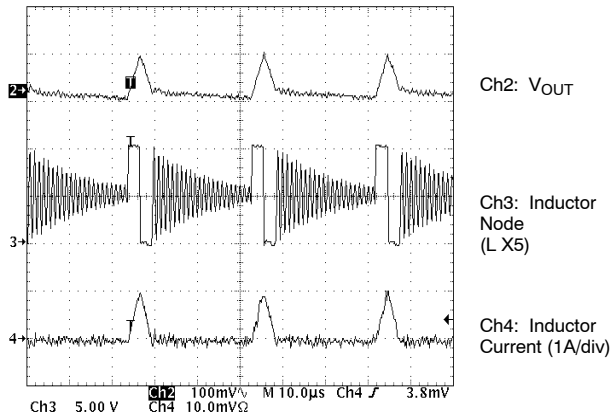

PSM Operation

5-V Converter ($V_{IN} = 10\text{ V}$)

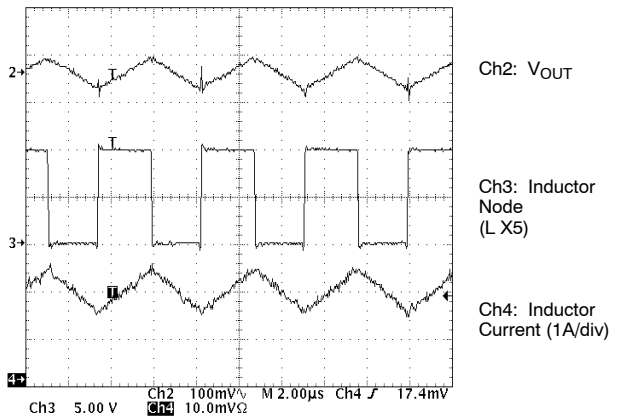

PWM Operation

TYPICAL WAVEFORMS

3-V Converter ($V_{IN} = 10\text{ V}$)

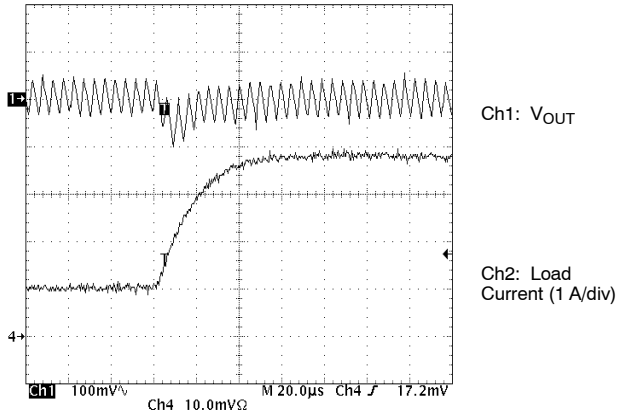

PWM, Loading

3-V Converter ($V_{IN} = 10\text{ V}$)

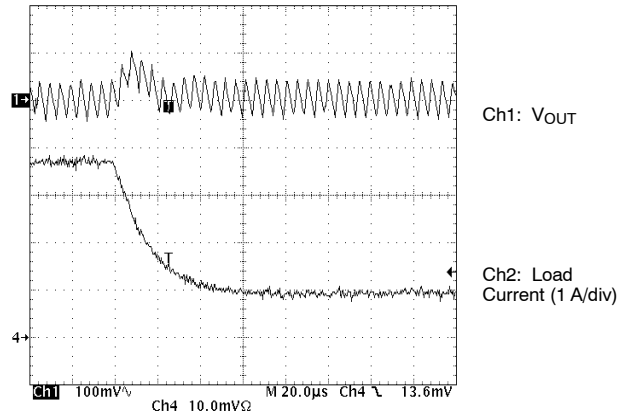

PWM, Unloading

3-V Converter ($V_{IN} = 10\text{ V}$)

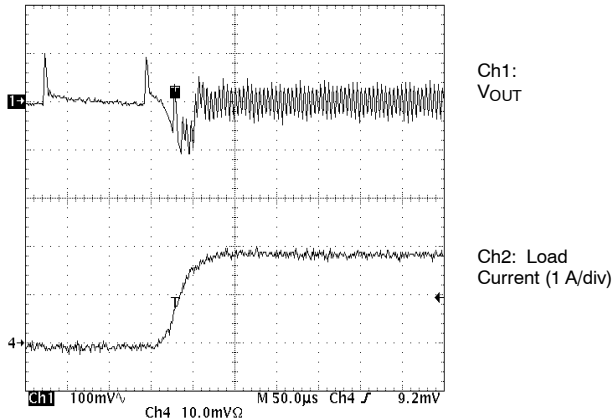

PSM \rightarrow PWM

3-V Converter ($V_{IN} = 10\text{ V}$)

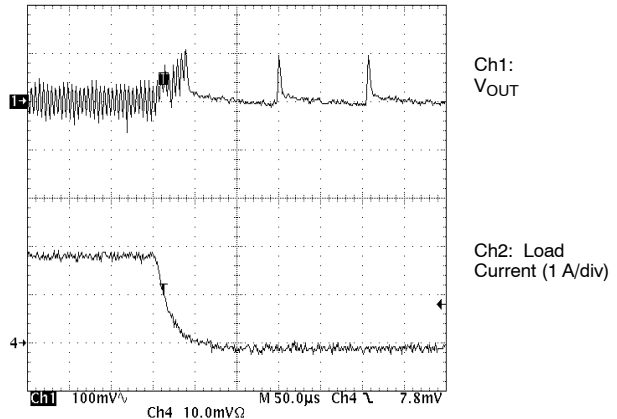

PWM \rightarrow PSM

12-V Converter ($V_{IN} = 10\text{ V}$)

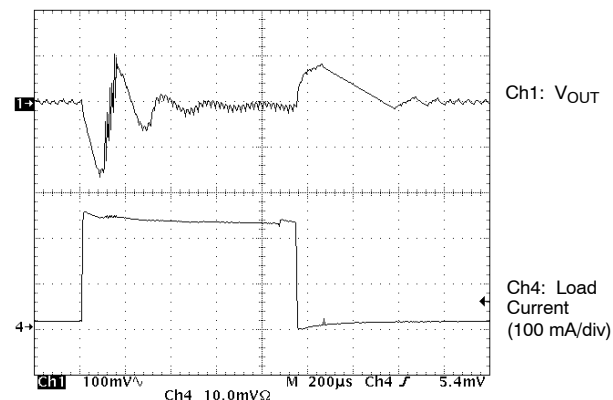

250-mA Transient

Start-Up

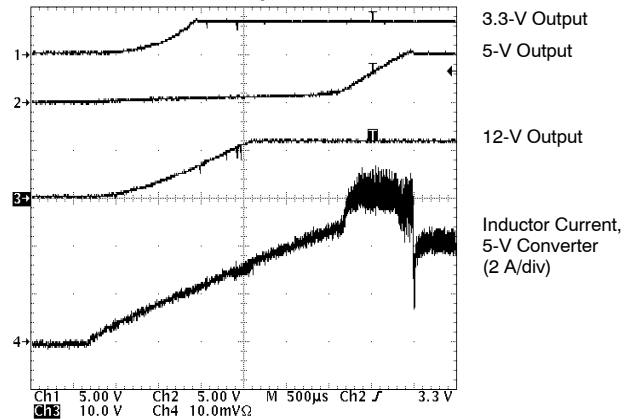

STANDARD APPLICATION CIRCUIT

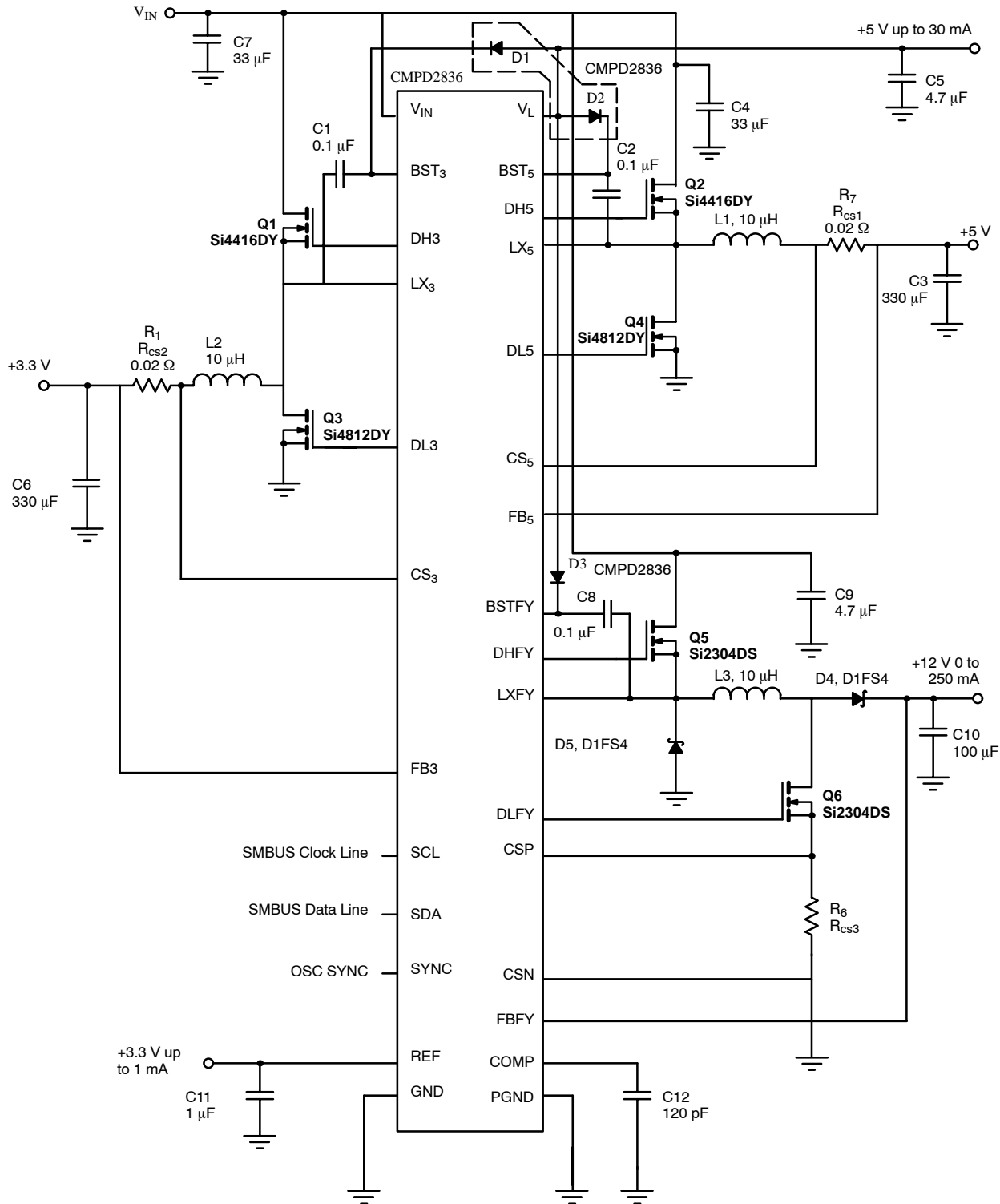

FIGURE 1.



SMBUS Specification

SMBus: The System Management Bus is a two-wire interface through which simple power related chips can communicate with the rest of the system. It uses I²C as its backbone. Both SDA and SCL are bidirectional lines, connected to a positive voltage via a pull-up resistor. When the bus is free, both lines

are high. The output stages of devices connected to the bus must have an open drain or open collector in order to perform the wired AND function. Data on the SMBus can be transferred at a clock rate up to 100 kHz. Si9135 is a slave with SMBus address of 0110000.

SMBUS TRUTH TABLE								
State	D7	D6	D5	D4	D3	D2	D1	D0
Shutdown	0	0	0	X	X	X	X	X
Buck3 On	1	0	0	X	X	X	X	X
Buck5 On	0	1	0	X	X	X	X	X
Flyback On	0	0	1	X	X	X	X	X
Buck3, Buck5 On	1	1	0	X	X	X	X	X
Buck3, Flyback On	1	0	1	X	X	X	X	X
Buck5, Flyback on	0	1	1	X	X	X	X	X
All On	1	1	1	X	X	X	X	X

- Notes
 1. Positive logic level is used
 2. X: don't care

SMBUS ELECTRICAL SPECIFICATION (TEST CONDITIONS: V ₊ = 5.5 TO 30 V, T _A = 0 °C)				
Symbol	Parameter	Min	Max	Units
V _{IL}	Data, Clock Input Low Voltage	-0.5	0.6	V
V _{IH}	Data, Clock Input High Voltage	1.4	5.5	
V _{OL}	Data, Clock Output Low Voltage		0.4	
I _{LEAK}	Input Leakage		±1	µA

SMBUS AC SPECIFICATIONS				
Symbol	Parameter	Min	Max	Units
F _{SMB}	SMBus Operation Frequency	10	100	kHz
T _{BUF}	Bus free time between Stop and Start	4.7		µs
T _{HD}	Data Hold Time	300		ns
T _{SU}	Data Setup Time	250		
T _{LOW}	Clock Low Period	4.7		µs
T _{HIGH}	Clock High Period	4.0	50	
T _F	Clock/Data Fall Time		300	ns
T _R	Clock/Data Rise Time		1000	

TIMING DIAGRAMS

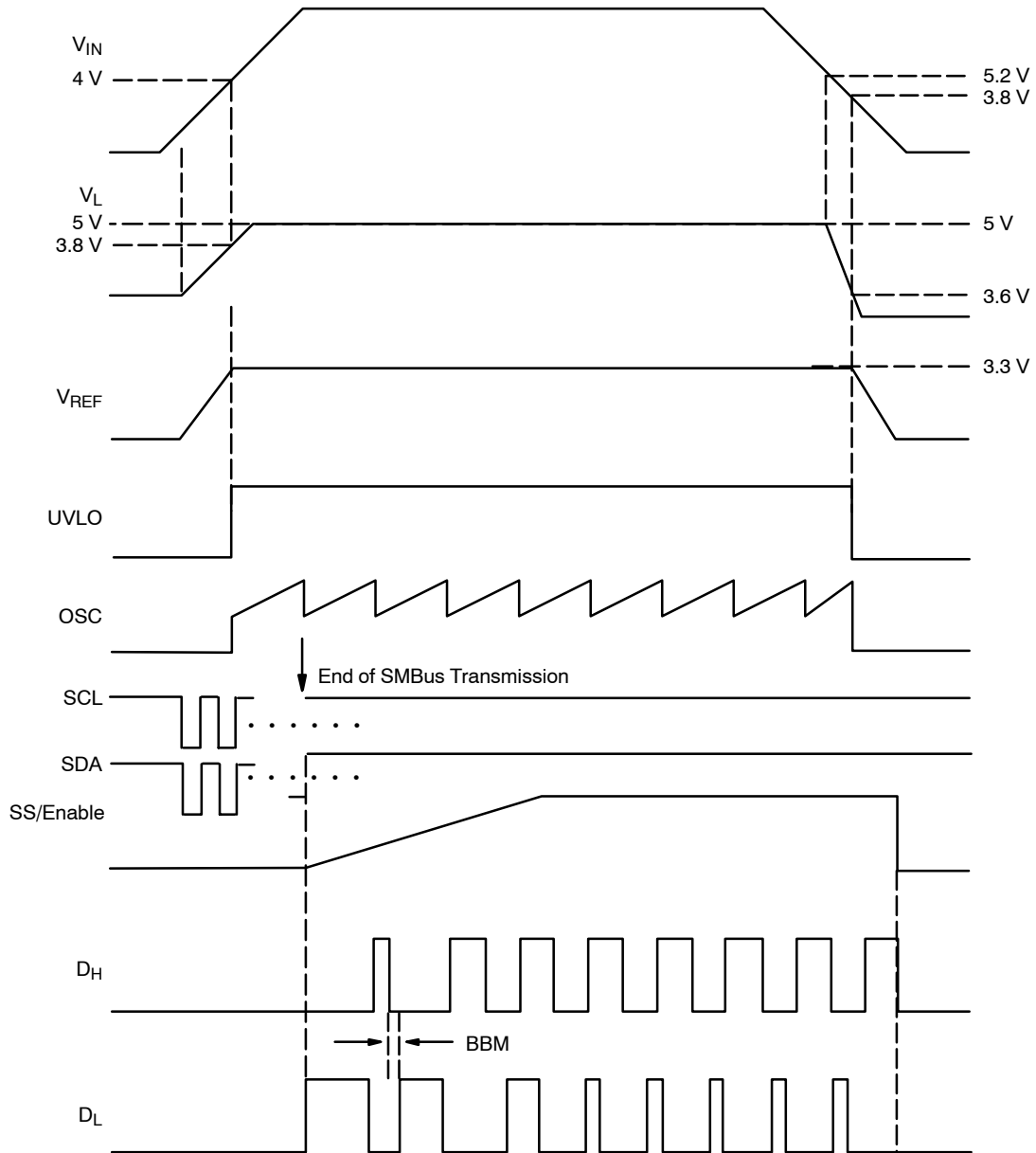

FIGURE 2. Start-Up Timing Sequence

DETAILED FUNCTIONAL BLOCK DIAGRAMS

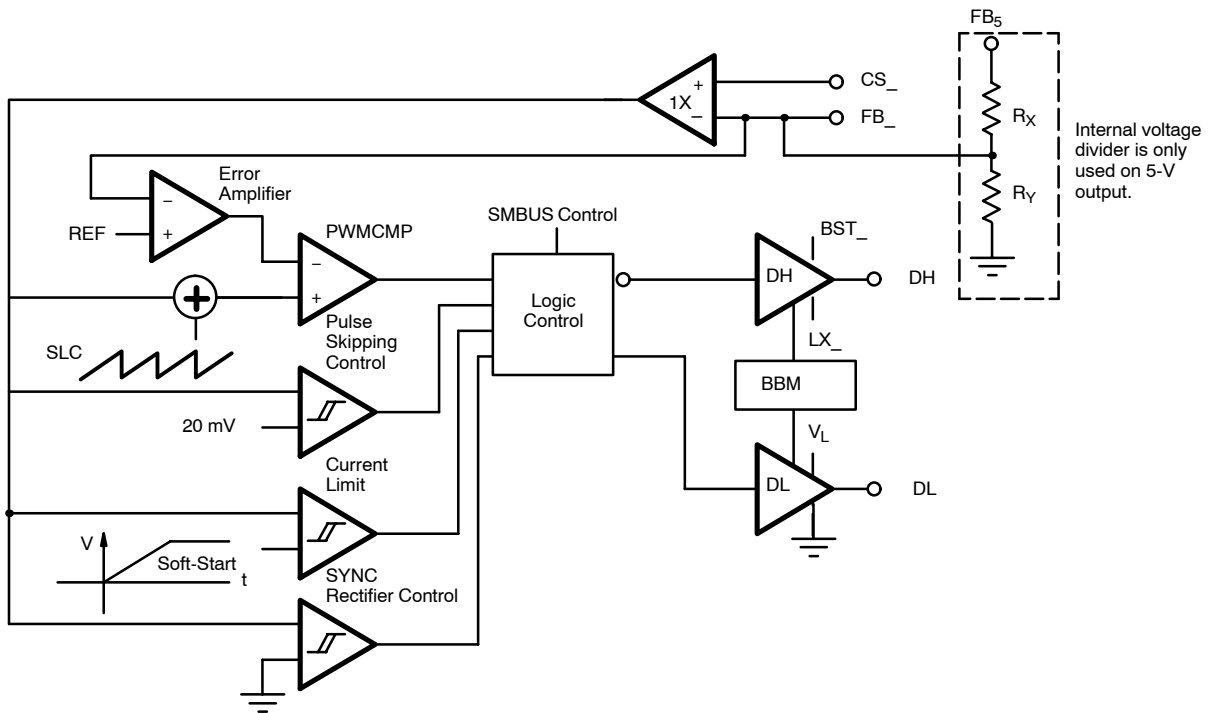

FIGURE 3. Buck Block Diagram

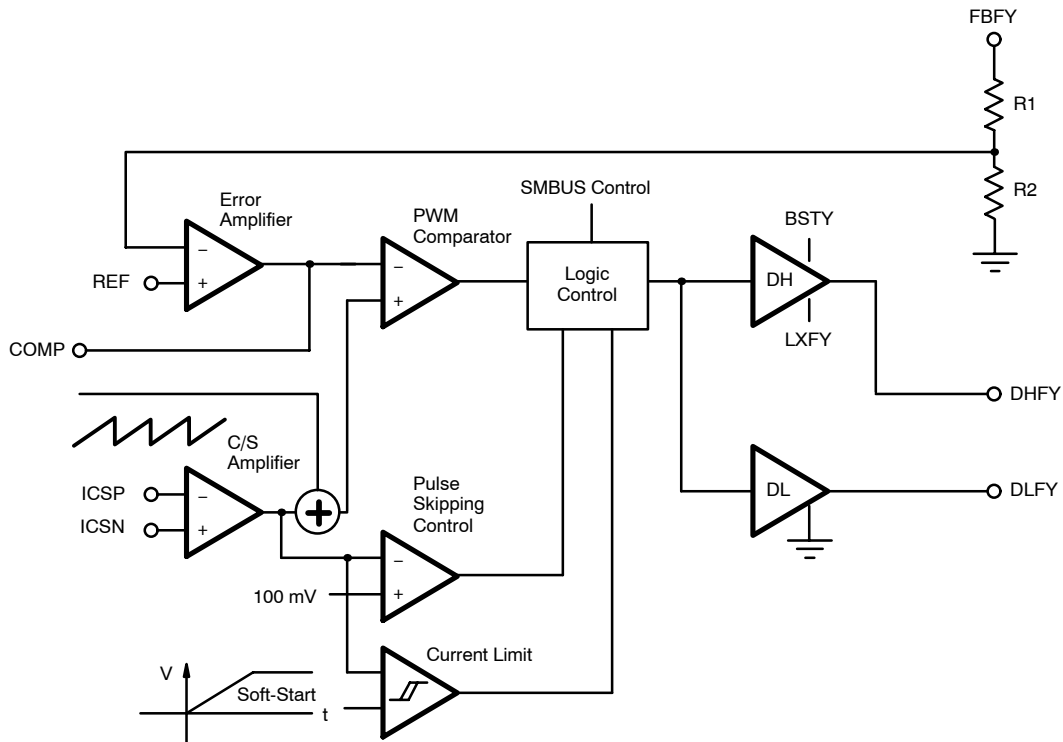

FIGURE 4. PWM Flyback Block Diagram

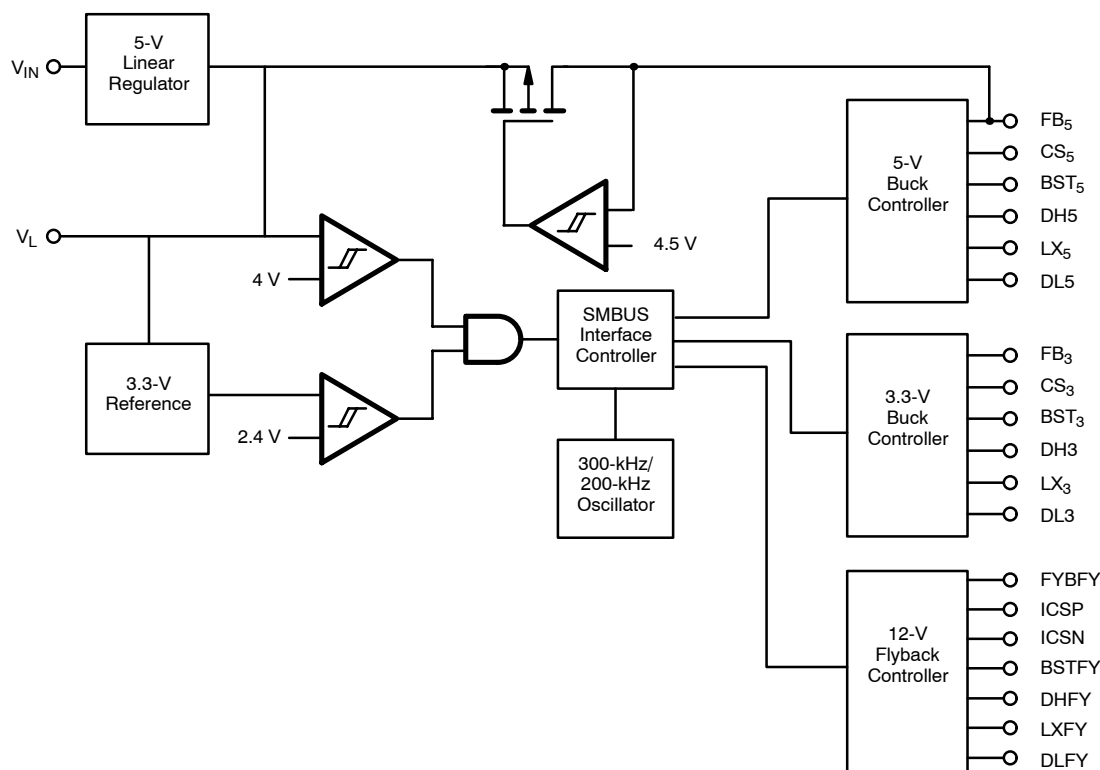

FIGURE 5. Complete Si9135 Block Diagram

DESCRIPTION OF OPERATION

Start-up Sequence

Si9135 is normally controlled by its SMBus interface after V_{IN} is applied. Initially, if there is no incoming SMBus control command, it comes up in its default power on sequence, first the LDO 5 V will come up within its tolerance, and then the precision 3.3-V reference will come up. Immediately afterwards, the oscillator will begin and 3.3-V BUCK converter will turn on and then 5-V BUCK converter and at last 12-V FLYBACK converter. If Si9135 receives any SMBus controlling command after LDO 5 V is established, the designated converters will be allowed to turn on or off independently depending on the command received. In the event of all three converters are turned off, the oscillator will be turned off, the total system would only draw 35- μ A supply current.

Each converter can soft-start separately. The integrated internal soft-start circuitry for each converter gradually increases the inductor maximum peak current during soft-start period (approximately 4 msec), preventing excessive currents being drawn from the input during startup. The soft-start is

controlled by initial default start up sequence or incoming SMBus command.

Si9135 converts a 5.5-V to 30-V input voltage to five outputs, two BUCK (step-down) high current, PWM, switch-mode supplies, one at 3.3 V and one at 5 V, one FLYBACK 12-V PWM switch-mode supply, one precision 3.3-V reference and one 5-V Low Drop Out linear regulator output. Switch-mode supply output current capabilities depend on external components (can exceed 10 A). With typical application shown on the application diagram, the two BUCK converters deliver 4 A and the FLYBACK converters deliver 0.25 A. The recommended load current for precision 3.3-V reference output is less than 1 mA, the recommended load current for 5-V LDO output current is less than 30 mA. In order to maximize the power efficiency, when the 5-V BUCK converter supply is above 4.5 V, the BUCK converter's output is internal connected to LDO output.



DESCRIPTION OF OPERATION (CONT'D)

Buck Converter Operation

The 3.3-V and 5-V buck converters are both current-mode PWM and PSM (during light load operation) regulators using high-side bootstrap n-channel and low-side n-channel MOSFETs. At light load conditions, the converters switch at a lower frequency than the clock frequency, seen like some clock pulses between the actual switching are skipped, this operating condition is defined as pulse-skipping. The operation of the converter(s) switching at clock frequency is defined as normal operation.

Normal Operation: Buck Converters

In normal operation, the buck converter high-side MOSFET is turned on with a delay (known as break-before-make time - t_{BBM}), after the rising edge of the clock. After a certain on time, the high-side MOSFET is turned off and then after a delay (t_{BBM}), the low-side MOSFET is turned on until the next rising edge of the clock, or the inductor current reaches zero. The t_{BBM} (approximately 25 ns to 60 ns), has been optimized to guarantee the efficiency is not adversely affected at the high switching frequency and a specified minimum to account for variations of possible MOSFET gate capacitances.

During the normal operation, the high-side MOSFET switch on-time is controlled internally to provide excellent line and load regulation over temperature. Both buck converters should have load, line, regulation to within 0.5% tolerance.

Pulse Skipping: Buck Converters

When the buck converter switching frequency is less than the internal clock frequency, its operation mode is defined as pulse skipping mode. During this mode, the high-side MOSFET is turned on until $V_{CS}-V_{FB}$ reaches 20 mV, or the on time reaches its maximum duty ratio. After the high-side MOSFET is turned off, the low-side MOSFET is turned on after the t_{BBM} delay, which will remain on until the inductor current reaches zero. The output voltage will rise slightly above the regulation voltage after this sequence, causing the controller to stay idle for the next one, or several clock cycles. When the output voltage falls slightly below the regulation level, the high-side MOSFET will be turned on again at the next clock cycle. With the converter remaining idle during some clock cycles, the switching losses are reduced in order to preserve conversion efficiency during the light output current condition.

Current Limit: Buck Converters

When the buck converter inductor current is too high, the voltage across pin CS3(5) and pin FB3(5) exceeds approximately 120 mV, the high-side MOSFET would be turned off instantaneously regardless of the input, or output condition. The Si9135 features clock cycle by clock cycle current limiting capability.

Flyback Converter Operation

Designed mainly for PCMCIA or EEPROM programming, the Si9135 has a 12-V output non-isolated buck boost converter, called for brevity a flyback. It consists of two n-channel MOSFET switches that are turned on and off in phase, and two diodes. Similar to the buck converter, during the light load conditions, the flyback converter will switch at a frequency lower than the internal clock frequency, which can be defined as pulse skipping mode (PSM); otherwise, it is operating in normal PWM mode.

Normal Operation: Flyback Converter

In normal operation mode, the two MOSFETs are turned on at the rising edge of the clock, and then turned off. The on time is controlled internally to provide excellent load, line, and temperature regulation. The flyback converter has load, line and temperature regulation well within 0.5%.

Pulse Skipping: Flyback Converter

Under the light load conditions, similar to the buck converter, the flyback converter will enter pulse skipping mode. The MOSFETs will be turned on until the inductor current increases to such a level that the voltage across the pin CSP and pin CSN reaches 100 mV, or the on time reaches the maximum duty cycle. After the MOSFETs are turned off, the inductor current will conduct through two diodes until it reaches zero. At this point, the flyback converter output will rise slightly above the regulation level, and the converter will stay idle for one or several clock cycle(s) until the output falls back slightly below the regulation level. The switching losses are reduced by skipping pulses and so the efficiency during light load is preserved.

Current Limit: Flyback Converter

Similar to the buck converter; when the voltage across pin CSP and pin CSN exceeds 410-mV typical, the two MOSFETs will be turned off regardless of the input and output conditions.

DESCRIPTION OF OPERATION (CONT'D)

SMBus Commands

After completion of startup, Si9135's converters can be individually or as a group commanded on or off using a code word on the SMBus, as detailed in the SMBus Truth Table. The command sequence is:

1. Receive a start bit, which is a falling edge on the SDA line while the SCL line is high.
2. Receive a one-byte address, which for Si9135 is 01100000.
3. Send an acknowledge bit.
4. Receive a one-byte command.
5. Send an acknowledge bit.
6. Receive a stop bit, which is a rising edge on the SDA line while the SCL line is high.

This is a total of 20 bits, which at the maximum clock frequency of 100 kHz translates into 200 μ sec before any change in the status of Si9135 can be accomplished.

If Si9135 receives a command to turn on (respectively, off) a converter that is already on (respectively, off) it shall not falsely command the converter off (respectively, on).

Si9135 must be able to receive a stop command at any time during a command sequence. If Si9135 receives a stop command during a command sequence, it must not change the state of any converter, and must be ready to receive the next command sequence.

Grounding

There are two separate grounds on the Si9135, analog signal ground (GND) and power ground (PGND). The purpose of two separate grounds is to prevent the high currents on the power devices (both external and internal) from interfering with the analog signals. The internal components of Si9135 have their grounds tied (internally) together. These two grounds are then tied together (externally) at a single point, to ensure Si9135 noise immunity.

This separation of grounds should be maintained in the external circuitry, with the power ground of all power devices being returned directly to the input capacitors, and the small signal ground being returned to the GND pin of Si9135.

ON/OFF Function

Logic-low shuts off the appropriate section by disabling the gate drive stage. High-side and low-side gate drivers are turned off when ON/OFF pins are logic-low. Logic-high enables the DH and DL pins.

Stability

Buck Converters:

In order to simplify designs, the Si9135 requires no specified external components except load capacitors for stability control. Meanwhile, it achieves excellent regulation and efficiency. The converters are current mode control, with a bandwidth substantially higher than the LC tank dominant pole frequency of the output filter. To ensure stability, the minimum capacitance and maximum ESR values are:

$$C_{LOAD} \geq \frac{V_{REF}}{2\pi \times V_{OUT} \times R_{CS} \times BW} \quad ESR \leq \frac{V_{OUT} \times R_{CS}}{V_{REF}}$$

Where $V_{REF} = 3.3$ V, V_{OUT} is the output voltage (5 V or 3.3 V), R_{CS} is the current sensing resistor in ohms and $BW = 50$ kHz

With the components specified in the application circuit ($L = 10$ μ H, $R_{CS} = 0.02$ Ω , $C_{OUT} = 330$ μ F, ESR approximately 0.1 Ω), the converter should have a bandwidth at approximately 50 kHz, with minimum phase margin of 65°, and dc gain above 50 dB.

Other Outputs

The Si9135 also provides a 3.3-V reference which can be external loaded up to 1 mA, as well as, a 5-V LDO output which can be loaded 30 mA, or even more depending on the system application. When the 5-V buck converter is turned on, the 5-V LDO output is shorted with the 5-V buck converter output, so its loading capability is substantially increased. For stability, the 3.3-V reference output requires a 1- μ F capacitor, and 5-V LDO output requires a 4.7- μ F capacitor.



Disclaimer

All product specifications and data are subject to change without notice.

Vishay Intertechnology, Inc., its affiliates, agents, and employees, and all persons acting on its or their behalf (collectively, "Vishay"), disclaim any and all liability for any errors, inaccuracies or incompleteness contained herein or in any other disclosure relating to any product.

Vishay disclaims any and all liability arising out of the use or application of any product described herein or of any information provided herein to the maximum extent permitted by law. The product specifications do not expand or otherwise modify Vishay's terms and conditions of purchase, including but not limited to the warranty expressed therein, which apply to these products.

No license, express or implied, by estoppel or otherwise, to any intellectual property rights is granted by this document or by any conduct of Vishay.

The products shown herein are not designed for use in medical, life-saving, or life-sustaining applications unless otherwise expressly indicated. Customers using or selling Vishay products not expressly indicated for use in such applications do so entirely at their own risk and agree to fully indemnify Vishay for any damages arising or resulting from such use or sale. Please contact authorized Vishay personnel to obtain written terms and conditions regarding products designed for such applications.

Product names and markings noted herein may be trademarks of their respective owners.