

3.9 Ω , 8-Channel / Dual 4-Channel, ± 15 V, +12 V, ± 5 V Precision Multiplexers

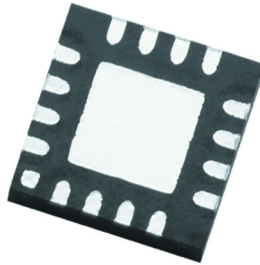

DESCRIPTION

The DG1408E is a precision analog multiplexer comprising eight single-ended channels. The DG1409E is a dual four single-ended channels analog multiplexer. Built on a new CMOS process, the Vishay Siliconix DG1408E and DG1409E offer low on-resistance of 3.9 Ω . The low and flat resistance over the full signal range provides excellent linearity and low signal distortion. The new CMOS platform also ensures ultra low power dissipation, minimized parasitic capacitance, and low charge injection.

The DG1408E and DG1409E can operate from either a single 4.5 V to 24 V power supply, or from dual ± 4.5 V to ± 15 V power supplies. The DG1408E connects one of eight inputs to a common output as determined by a 3-bit binary address (A0, A1, A2). The DG1409E connects one of four inputs to a common output for both multiplexers as determined by a 2-bit binary address (A0 and A1). Break-before-make switching action protects against momentary crosstalk between adjacent channels. The part does not require a VL logic supply, while all digital inputs have 0.8 V and 2 V logic thresholds to ensure low-voltage TTL / CMOS compatibility. Together with the compact package, these make the part a great fit for battery operated systems.

The DG1408E and DG1409E on channel conduct signal equally well in both directions. In the off state each channel blocks voltages up to the power supply rails. An enable (EN) function allows the user to reset the multiplexer / demultiplexer to all switches off for stacking several devices.

The advance performance of low insertion loss and low distortion make the device ideal for signal switching and relay replacement in a wide range of applications.

DG1408E and DG1409E are available in RoHS-compliant, halogen-free QFN16, 4 mm x 4 mm package.

FEATURES

- 35 V supply max. rating
- 3.9 Ω typical and 4.2 Ω max. on-resistance at 25 $^{\circ}$ C
- 0.59 Ω on-resistance flatness
- Channel to channel on-resistance match: 0.27 Ω
- Up to 250 mA continuous current
- Supports single and dual supply operation
- Fully specified at ± 15 V, +12 V, and ± 5 V
- Integrated VL supply
- Low voltage logic compatible inputs, $V_{IH} = 2$ V, $V_{IL} = 0.8$ V
- BBM (break-before-make switching)
- Low parasitic capacitance:
 DG1408E, $C_{S(off)} = 13$ pF, $C_{D(on)} = 104$ pF
 DG1409E, $C_{S(off)} = 13$ pF, $C_{D(on)} = 70$ pF
- Rail to rail signal handling
- QFN16, 4 mm x 4 mm packages
- Material categorization: for definitions of compliance please see www.vishay.com/doc?99912



RoHS
 COMPLIANT
 HALOGEN
FREE

BENEFITS

- Low insertion loss
- Low distortion
- Low power consumption
- Compact solution
- Low charge injection over the full signal range

APPLICATIONS

- Medical and healthcare equipment
- Data acquisition system
- Industrial control and automation
- Test and measurement equipment
- Communication systems
- Battery powered systems
- Sample and hold circuits
- Audio and video signal switching
- Relay replacement

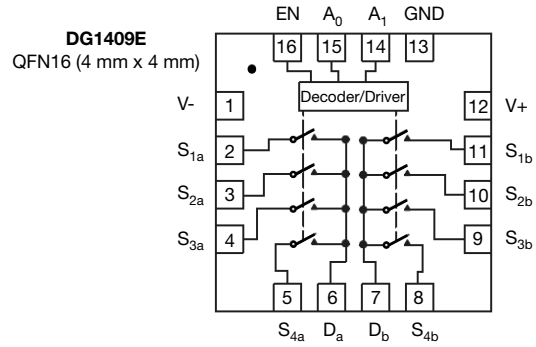
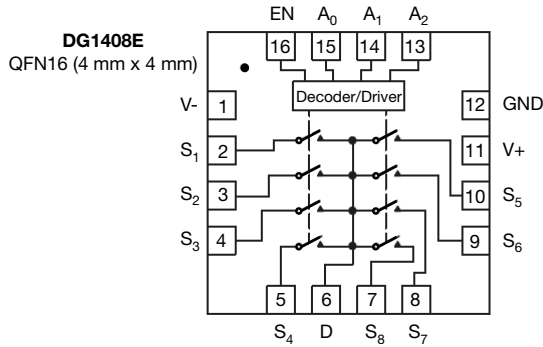
FUNCTIONAL BLOCK DIAGRAM AND PIN CONFIGURATION

TRUTH TABLE - DG1408E				
A2	A1	A0	EN	ON SWITCH
X	X	X	0	None
0	0	0	1	1
0	0	1	1	2
0	1	0	1	3
0	1	1	1	4
1	0	0	1	5
1	0	1	1	6
1	1	0	1	7
1	1	1	1	8

TRUTH TABLE - DG1409E			
A1	A0	EN	ON SWITCH
X	X	0	None
0	0	1	1
0	1	1	2
1	0	1	3
1	1	1	4

Note

- QFN exposed pad tied to V-

ORDERING INFORMATION			
CONFIGURATION	TEMPERATURE RANGE	PACKAGE	ORDERING PART NUMBER
8:1 MUX	-40 °C to +125 °C	QFN (4 mm x 4 mm) 16L (variation 2)	DG1408EEN-T1-GE4
Dual 4:1 MUX			DG1409EEN-T1-GE4

ABSOLUTE MAXIMUM RATINGS			
ELECTRICAL PARAMETER	CONDITIONS	LIMITS	UNIT
V+	Reference to GND	-0.3 V to +25 V	V
V-	Reference to GND	+0.3 V to -25 V	
V+ to V-		+35	
Analog inputs (S or D)		V- (-0.3 V) to V+ (+0.3 V)	
Digital inputs		GND (-0.3 V) to V+ (+0.3 V)	
Maximum continuous switch current	QFN (4 mm x 4 mm) 16L, T _A = 25 °C	250	mA
	QFN (4 mm x 4 mm) 16L, T _A = 125 °C	100	
Maximum pulse switch current	Pulse at 1 ms, 10 % duty cycle	500	
Thermal resistance	QFN (4 mm x 4 mm) 16L	32	°C/W
ESD human body model (HBM); per ANSI / ESDA / JEDEC® JS-001		6000	V
Latch up current, per JESD78D		200	mA
Temperature			
Operating temperature		-40 to +125	°C
Max. operating junction temperature		150	
Storage temperature		-65 to +150	

Stresses beyond those listed under "Absolute Maximum Ratings" may cause permanent damage to the device. These are stress ratings only, and functional operation of the device at these or any other conditions beyond those indicated in the operational sections of the specifications is not implied. Exposure to absolute maximum rating conditions for extended periods may affect device reliability.

RECOMMENDED OPERATING RANGE			
ELECTRICAL	MINIMUM	MAXIMUM	UNIT
Single supply (V+)	4.5	24	V
Dual supplies (V+ and V-)	± 4.5	± 16.5	



ELECTRICAL CHARACTERISTICS							
PARAMETER	SYMBOL	TEST CONDITIONS UNLESS OTHERWISE SPECIFIED V+ = 15 V, V- = -15 V V _{AX} , V _{EN} = 2 V, 0.8 V	+25 °C	-40 °C to +85 °C	-40 °C to +125 °C	MIN. / TYP. / MAX.	UNIT
Analog Switch							
Analog signal range	V _{ANALOG}		V- to V+			-	V
Drain-source, on-resistance	R _{DS(on)}	V _S = ± 10 V, I _S = -10 mA, V _L = +13.5 V, V _R = -13.5 V	3.9	-	-	Typ.	Ω
On-resistance flatness	R _{flat(on)}		4.2	5.1	6.1	Max.	
On-resistance matching	ΔR _{DS(on)}		0.59	-	-	Typ.	
			0.7	0.9	1.1	Max.	
Source off leakage current	I _{S(off)}	V _L = +16.5 V, V _R = -16.5 V, V _S = ± 10 V, V _D = ± 10 V	± 0.027	-	-	Typ.	nA
Drain off leakage current	I _{D(off)}		± 0.55	± 1	± 10	Max.	
			± 0.018	-	-	Typ.	
			± 0.45	± 2	± 20	Max.	
Drain on leakage current	I _{D(on)}	V _L = +16.5 V, V _R = -16.5 V, V _S = V _D = ± 10 V	± 0.05	-	-	Typ.	nA
			± 1.5	± 4	± 35	Max.	
Digital Control							
Input, high voltage	V _{INH}		-	-	2	Min.	V
Input, low voltage	V _{INL}		-	-	0.8	Max.	
Input leakage	I _{IN}	V _{IN} = V _{GND} or V+	0.016	-	-	Typ.	μA
			-	-	± 0.1	Max.	
Digital input capacitance	C _{IN}		3.1	-	-	Typ.	pF
Dynamic Characteristics							
Transition time	t _{TRANS}	V _{S1} = +10 V / -10 V, V _{S8} = -10 V / +10 V, R _L = 100 Ω, C _L = 35 pF	133	-	-	Typ.	ns
			180	214	245	Max.	
Break-before-make time	t _{OPEN}	V _{S1} = V _{S8} = 10 V, R _L = 100 Ω, C _L = 35 pF	29	-	-	Typ.	
			-	-	10	Min.	
Enable turn-on time	t _{ON(EN)}	V _{S1} = 10 V, V _{S2} - V _{S8} = 0 V, R _L = 100 Ω, C _L = 35 pF	100	-	-	Typ.	
Enable turn-off time	t _{OFF(EN)}		130	160	185	Max.	
			75	-	-	Typ.	pC
			105	120	140	Max.	
Charge injection	Q _{INJ}	C _{INJ} = 1 nF, R _{GEN} = 0 Ω, V _S = 0 V	DG1408E -31	-	-	Typ.	pC
			DG1409E -103	-	-	Typ.	
Off isolation	OIRR	C _L = 5 pF, R _L = 50 Ω, 1 MHz	-58	-	-	Typ.	dB
Cross talk	X _{TALK}		-64	-	-	Typ.	
Total harmonic distortion + N	THD + N	R _L = 100 Ω, 15 V _{p-p} , f = 20 Hz to 20 kHz	0.025	-	-	Typ.	%
-3 dB, bandwidth	BW	R _L = 50 Ω	DG1408E 55	-	-	Typ.	MHz
			DG1409E 90	-	-	Typ.	
Source off capacitance	C _{S(off)}	f = 1 MHz, V _S = 0 V	13	-	-	Typ.	pF
Drain off capacitance	C _{D(off)}		DG1408E 85	-	-	Typ.	
			DG1409E 43	-	-	Typ.	
Drain on capacitance	C _{D(on)}		DG1408E 104	-	-	Typ.	
			DG1409E 70	-	-	Typ.	
Power Supply							
Power supply range		GND = 0 V	± 4.5 / ± 16.5			Min. / Max.	V
Positive supply current	I+	V _{AX} , V _{EN} = 0 V, 5 V, V+, V _L = +16.5 V, V _R = -16.5 V	3.4	3.8	4	Typ.	μA
			-	-	10	Max.	
Negative supply current	I-	V _{AX} , V _{EN} = 0 V, V+, V _L = +16.5 V, V _R = -16.5 V	0.0002	0.0085	0.33	Typ.	μA
			-	-	1	Max.	



ELECTRICAL CHARACTERISTICS								
PARAMETER	SYMBOL	TEST CONDITIONS UNLESS OTHERWISE SPECIFIED V ₊ = 12 V, V ₋ = 0 V V _{AX} , V _{EN} = 2 V, 0.8 V	+25 °C	-40 °C to +85 °C	-40 °C to +125 °C	MIN. / TYP. / MAX.	UNIT	
Analog Switch								
Analog signal range	V _{ANALOG}		0 to V ₊			-	V	
Drain-source, on-resistance	R _{DS(on)}	V _S = 0 V / 10 V, I _S = -10 mA, V ₊ = +10.8 V, V ₋ = 0 V	7.5	-	-	Typ.	Ω	
			8	10	12	Max.		
On-resistance flatness	R _{flat(on)}		2	-	-	Typ.		
			2.2	2.5	3	Max.		
On-resistance matching	ΔR _{DS(on)}		0.3	-	-	Typ.		
			0.5	0.8	1	Max.		
Source off leakage current	I _{S(off)}	V ₊ = +13.2 V, V ₋ = 0 V, V _S = 1 V / 10 V, V _D = 10 V / 1 V	± 0.01	-	-	Typ.	nA	
Drain off leakage current	I _{D(off)}		± 0.55	± 1	± 8	Max.		
			± 0.01	-	-	Typ.		
			± 0.3	± 2	± 20	Max.		
Drain on leakage current	I _{D(on)}	V ₊ = +13.2 V, V ₋ = 0 V, V _S = V _D = 1 V / 10 V	± 0.01	-	-	Typ.	nA	
		± 1.5	± 3	± 20	Max.			
Digital Control								
Input, high voltage	V _{INH}		-	-	2	Min.	V	
Input, low voltage	V _{INL}		-	-	0.8	Max.		
Input leakage	I _{IN}	V _{IN} = V _{GND} or V ₊	0.018	-	-	Typ.	μA	
			-	-	± 0.1	Max.		
Digital input capacitance	C _{IN}		3.1	-	-	Typ.	pF	
Dynamic Characteristics								
Transition time	t _{TRANS}	V _{S1} = 8 V / 0 V, V _{S8} = 0 V / 8 V, R _L = 100 Ω, C _L = 35 pF	134	-	-	Typ.	ns	
			190	235	280	Max.		
Break-before-make time	t _{OPEN}	V _{S1} = V _{S8} = 8 V, R _L = 100 Ω, C _L = 35 pF	64	-	-	Typ.	ns	
			-	-	14	Min.		
Enable turn-on time	t _{ON(EN)}	V _{S1} = 8 V, V _{S2} - V _{S8} = 0 V, R _L = 100 Ω, C _L = 35 pF	117	-	-	Typ.	ns	
			151	180	215	Max.		
Enable turn-off time	t _{OFF(EN)}		79	-	-	Typ.		
			105	125	145	Max.		
Charge injection	Q _{INJ}	C _{INJ} = 1 nF, R _{GEN} = 0 Ω, V _S = 6 V	DG1408E	5	-	-	Typ.	pC
			DG1409E	-22	-	-		
Off isolation	OIRR	C _L = 5 pF, R _L = 50 Ω, 1 MHz	-58	-	-	Typ.	dB	
Cross talk	X _{TALK}		-64	-	-			
Total harmonic distortion + N	THD + N	R _L = 100 Ω, 6 V _{p-p} , f = 20 Hz to 20 kHz	0.055	-	-	Typ.	%	
-3 dB bandwidth	BW	R _L = 50 Ω	DG1408E	50	-	-	Typ.	MHz
			DG1409E	78	-	-		
Source off capacitance	C _{S(off)}	f = 1 MHz, V _S = 6 V		16	-	-	Typ.	pF
Drain off capacitance	C _{D(off)}		DG1408E	100	-	-		
			DG1409E	53	-	-		
Drain on capacitance	C _{D(on)}		DG1408E	122	-	-		
		DG1409E	81	-	-			
Power Supply								
Power supply range		GND = 0 V, V ₋ = 0 V	4.5 / 24			Min. / Max.	V	
Positive supply current	I ₊	V _{AX} , V _{EN} = 0 V, V ₊ , V ₊ = +13.2 V, V ₋ = 0 V	2.8	4.8	5.5	Typ.	μA	
			-	-	8	Max.		
		V _{AX} , V _{EN} = 5 V, V ₊ = 13.2 V, V ₋ = 0 V	2.8	3.1	3.6	Typ.		
			-	-	8	Max.		



ELECTRICAL CHARACTERISTICS							
PARAMETER	SYMBOL	TEST CONDITIONS UNLESS OTHERWISE SPECIFIED V+ = 5 V, V- = -5 V V _{AX} , V _{EN} = 2 V, 0.8 V	+25 °C	-40 °C to +85 °C	-40 °C to +125 °C	MIN. / TYP. / MAX.	UNIT
Analog Switch							
Analog signal range	V _{ANALOG}		V- to V+			-	V
Drain-source, on-resistance	R _{DS(on)}	V _S = ± 3.5 V, I _S = -10 mA, V+ = +4.5 V, V- = -4.5 V	8.8	-	-	Typ.	Ω
			10	12	14	Max.	
On-resistance flatness	R _{flat(on)}		2	-	-	Typ.	
			2.5	3	3.2	Max.	
On-resistance matching	ΔR _{DS(on)}		0.36	-	-	Typ.	
			0.55	1	1.5	Max.	
Source off leakage current	I _{S(off)}	V+ = +5.5 V, V- = -5.5 V, V _S = ± 4.5 V, V _D = ± 4.5 V	± 0.04	-	-	Typ.	nA
			± 0.55	± 1	± 10	Max.	
Drain off leakage current	I _{D(off)}		± 0.04	-	-	Typ.	
		± 0.3	± 3	± 20	Max.		
Drain on leakage current	I _{D(on)}	V+ = +5.5 V, V- = -5.5 V, V _S = V _D = ± 4.5 V	± 0.05	-	-	Typ.	
			± 1.5	± 4	± 30	Max.	
Digital Control							
Input, high Voltage	V _{INH}		-	-	2	Min.	V
Input, low Voltage	V _{INL}		-	-	0.8	Max.	
Input leakage	I _{IN}	V _{IN} = V _{GND} or V+	0.017	-	-	Typ.	μA
			-	-	± 0.1	Max.	
Digital input capacitance	C _{IN}		3.1	-	-	Typ.	pF
Dynamic Characteristics							
Transition time	t _{TRANS}	V _{S1} = +3 V / -3 V, V _{S8} = -3 V / +3 V, R _L = 100 Ω, C _L = 35 pF	160	-	-	Typ.	ns
			210	260	280	Max.	
Break-before-make time	t _{OPEN}	V _{S1} = V _{S8} = 3 V, R _L = 100 Ω, C _L = 35 pF	73	-	-	Typ.	
			-	-	10	Min.	
Enable turn-on time	t _{ON(EN)}	V _{S1} = 3 V, V _{S2} - V _{S8} = 0 V, R _L = 100 Ω, C _L = 35 pF	120	-	-	Typ.	
				160	200	230	
Enable turn-off time	t _{OFF(EN)}			86	-	-	Typ.
			110	132	155	Max.	
Charge injection	Q _{INJ}	C _{INJ} = 1 nF, R _{GEN} = 0 Ω, V _S = 0 V	DG1408E 7	-	-	Typ.	pC
			DG1409E -15	-	-		
Off isolation	OIRR	C _L = 5 pF, R _L = 50 Ω, 1 MHz	-58	-	-	Typ.	dB
Cross talk	X _{TALK}		-64	-	-		
Total harmonic distortion + N	THD + N	R _L = 100 Ω, 5 V _{p-p} , f = 20 Hz to 20 kHz	0.07	-	-	Typ.	%
-3 dB, bandwidth	BW	R _L = 50 Ω	DG1408E 46	-	-	Typ.	MHz
			DG1409E 78	-	-		
Source off capacitance	C _{S(off)}	f = 1 MHz, V _S = 0 V	17	-	-	Typ.	pF
Drain off capacitance	C _{D(off)}		DG1408E 109	-	-	Typ.	
			DG1409E 55	-	-		
Drain on capacitance	C _{D(on)}		DG1408E 126	-	-	Typ.	
		DG1409E 83	-	-			
Power Supply							
Power supply range		GND = 0 V	± 4.5 / ± 16.5			Min. / Max.	V
Positive supply current	I+	V _{AX} , V _{EN} = 0 V, 3 V, V+, V+ = +5.5 V, V- = -5.5 V	1.7	2.2	2.4	Typ.	μA
			-	-	5	Max.	
Negative supply current	I-	V _{AX} , V _{EN} = 0 V, V+, V+ = +5.5 V, V- = -5.5 V	0.08	0.12	0.14	Typ.	μA
			-	-	1	Max.	



TYPICAL CHARACTERISTICS (T_A = 25 °C, unless otherwise noted)

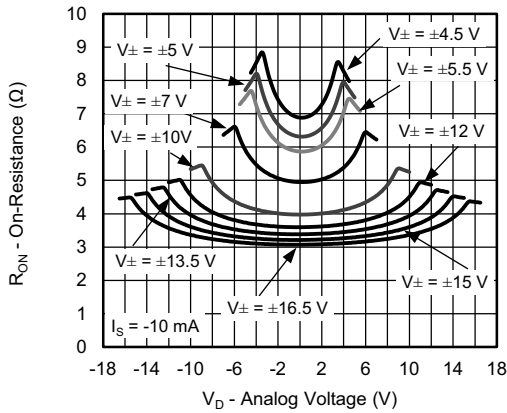

On-Resistance vs. Analog Voltage

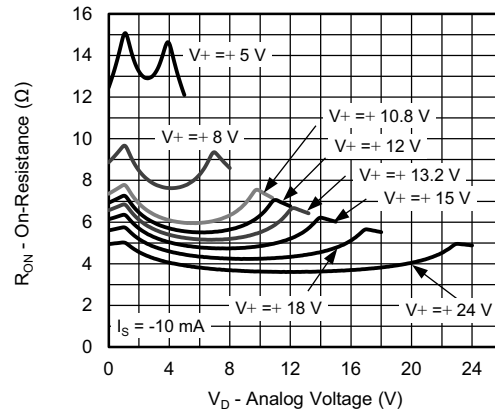

On-Resistance vs. Analog Voltage

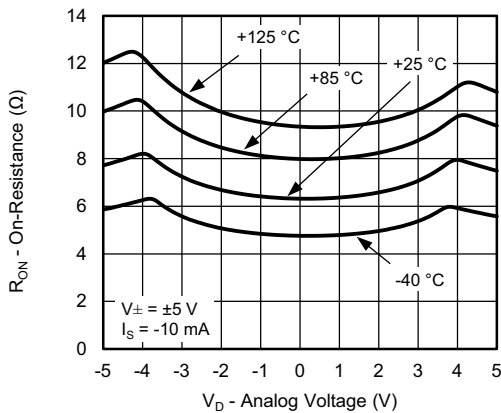

On-Resistance vs. Analog Voltage

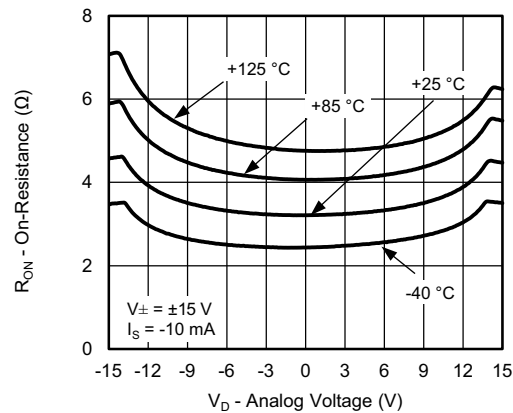

On-Resistance vs. Analog Voltage

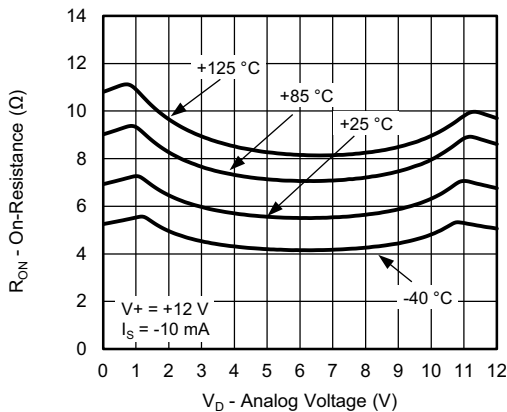

On-Resistance vs. Analog Voltage

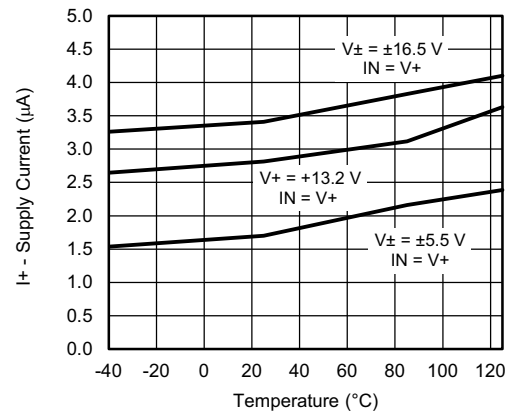

Supply Current vs. Temperature



TYPICAL CHARACTERISTICS (T_A = 25 °C, unless otherwise noted)

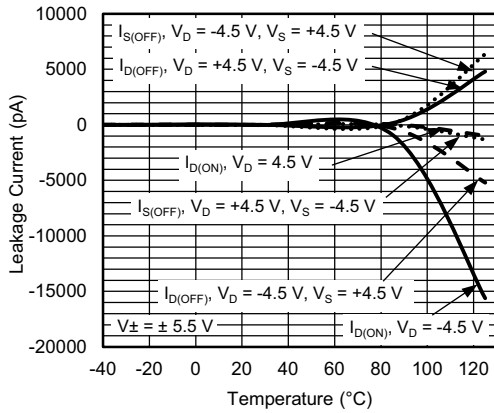

Leakage Current vs. Temperature

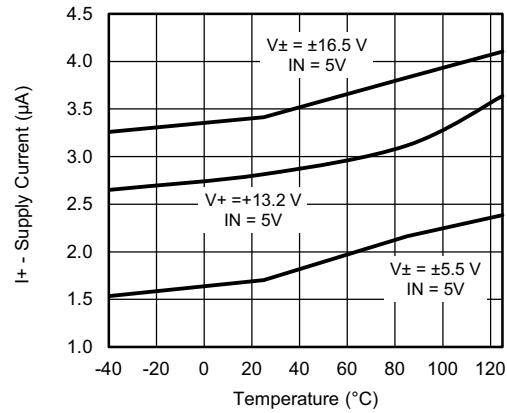

Supply Current vs. Temperature

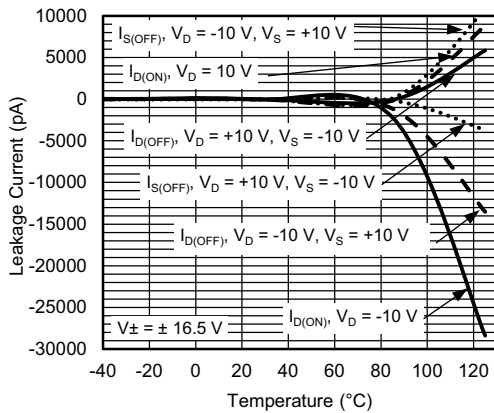

Leakage Current vs. Temperature

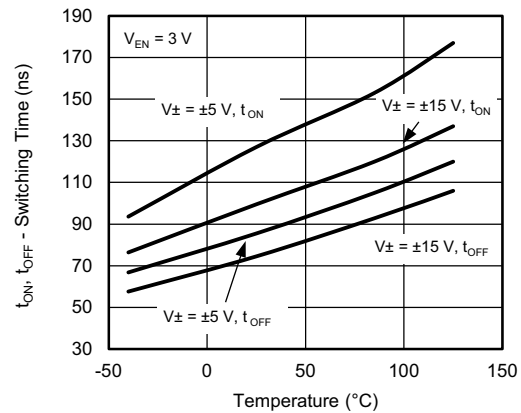

Switching Time vs. Temperature

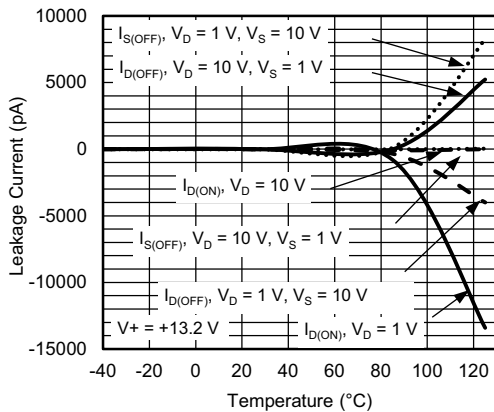

Leakage Current vs. Temperature

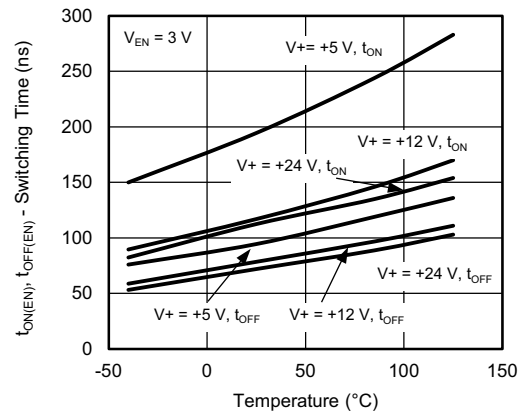

Switching Time vs. Temperature



TYPICAL CHARACTERISTICS (T_A = 25 °C, unless otherwise noted)

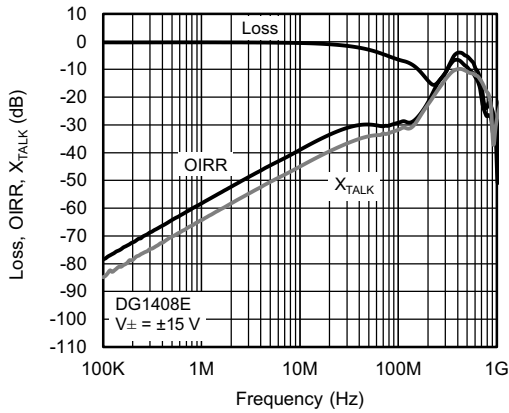

Loss, OIRR, X_{TALK} vs. Frequency

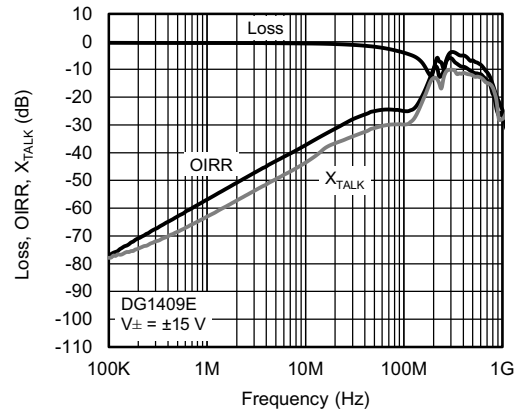

Loss, OIRR, X_{TALK} vs. Frequency

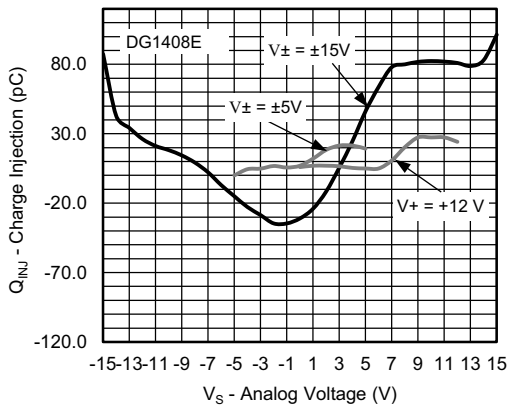

Charge Injection vs. Source Voltage

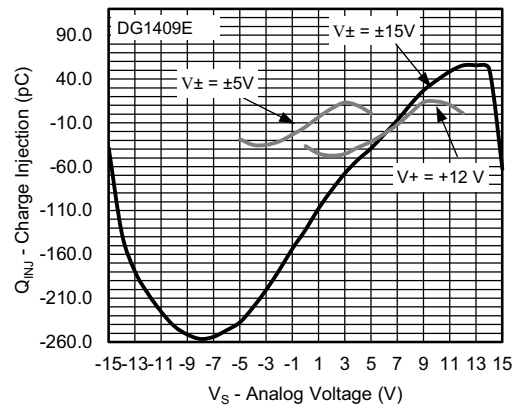

Charge Injection vs. Source Voltage

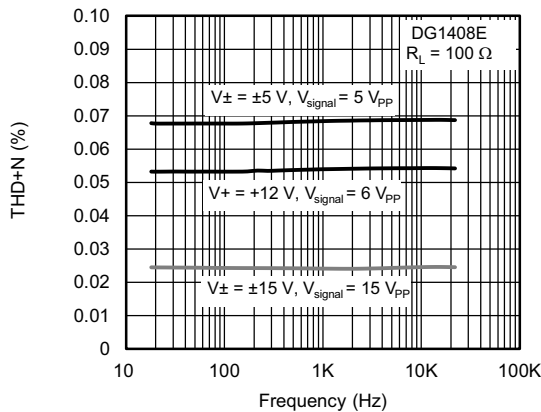

THD + N vs. Frequency

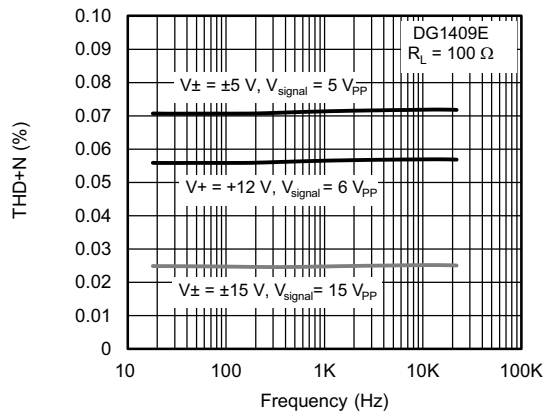

THD + N vs. Frequency



TYPICAL CHARACTERISTICS (T_A = 25 °C, unless otherwise noted)

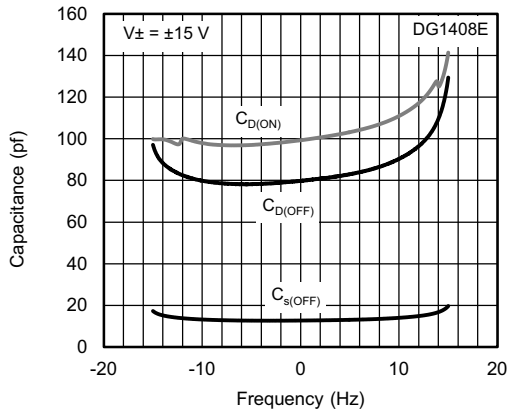

Capacitance vs. Analog Voltage

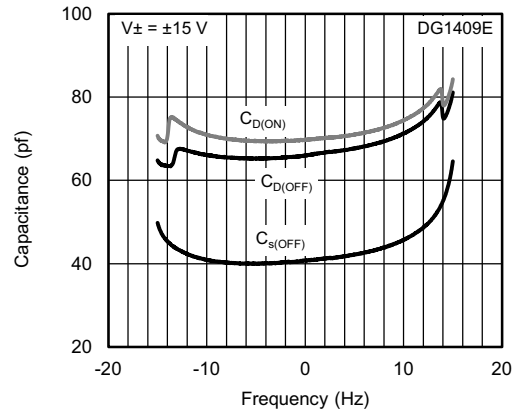

Capacitance vs. Analog Voltage

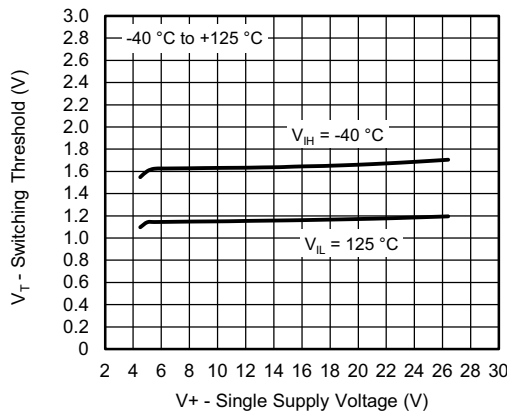

Switching Threshold vs. Supply Voltage

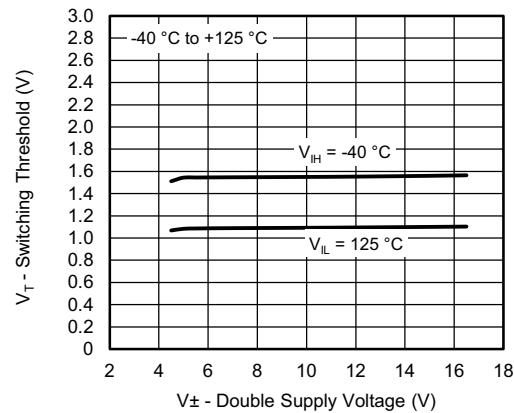

Switching Threshold vs. Supply Voltage

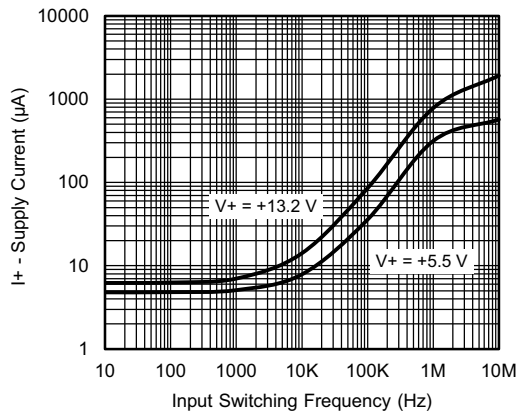

Positive Supply Current vs. Switching Frequency

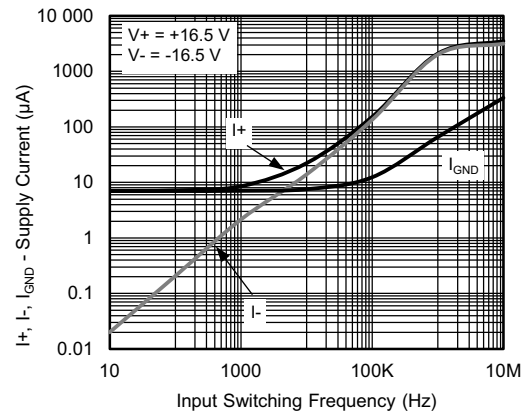

Double Supply Current vs. Switching Frequency

TEST CIRCUITS

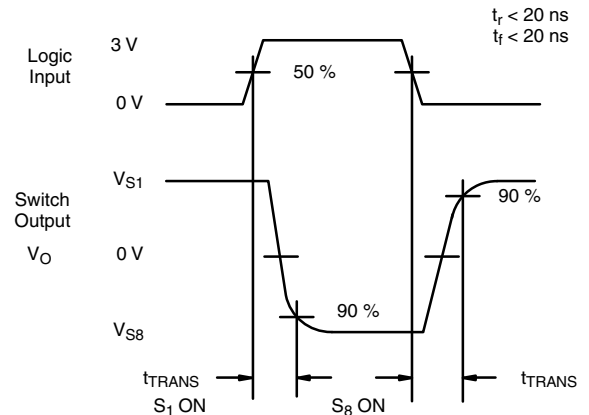
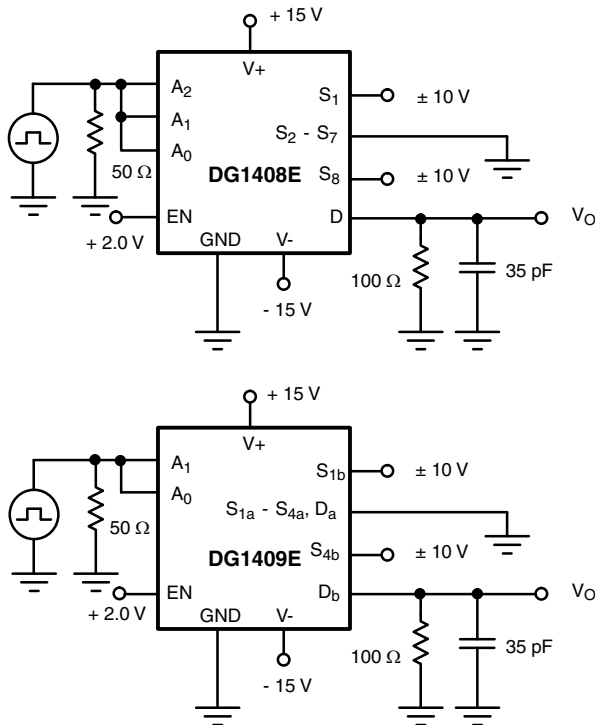

Fig. 1 - Transition Time

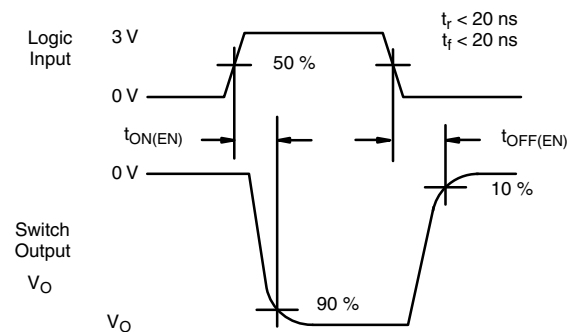
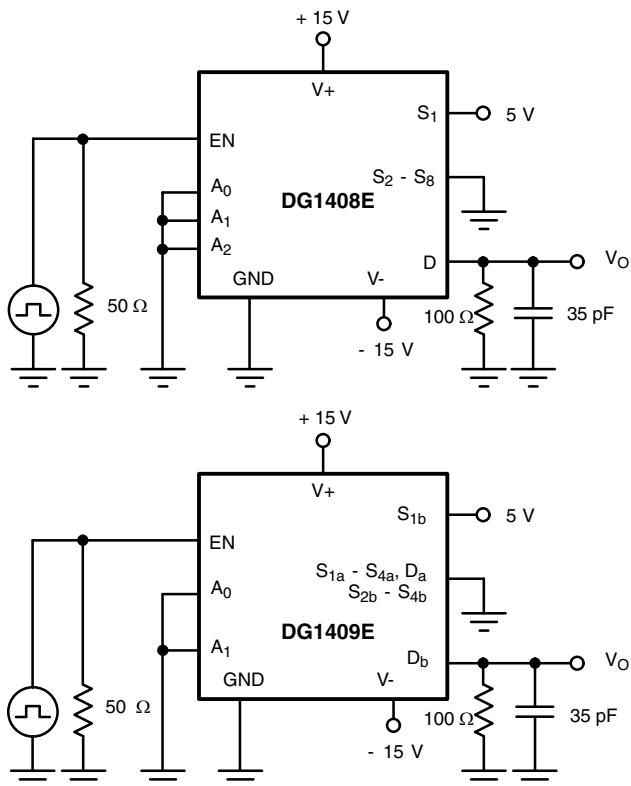

Fig. 2 - Enable Switching Time

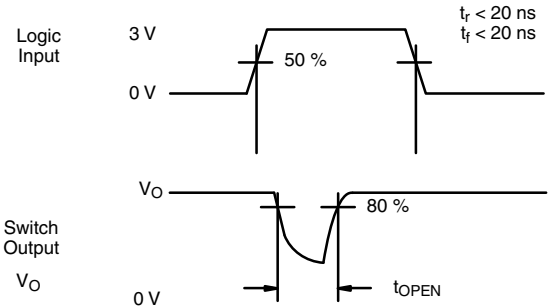
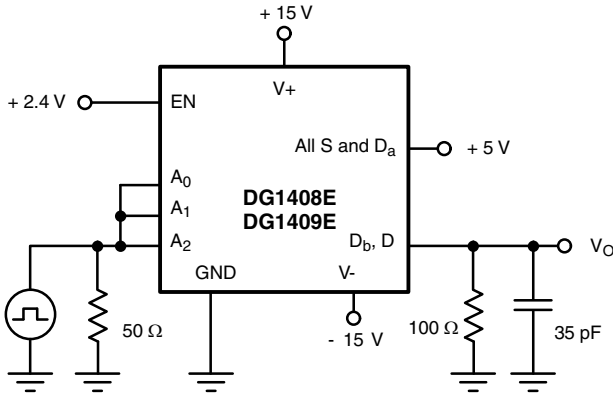

Fig. 3 - Break-Before-Make Internal

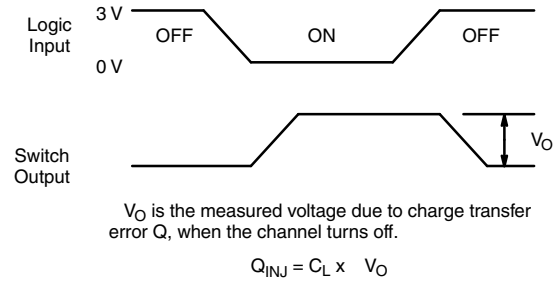
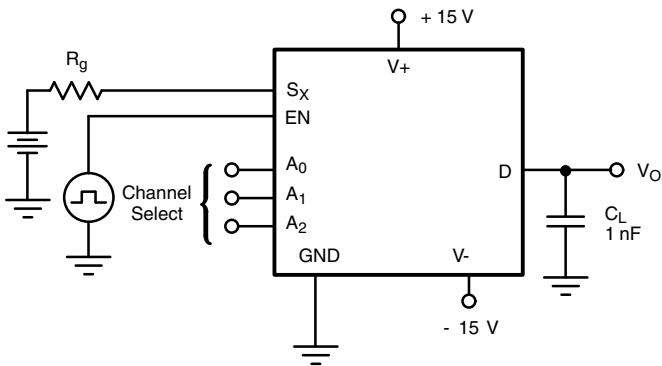

Fig. 4 - Charge Injection

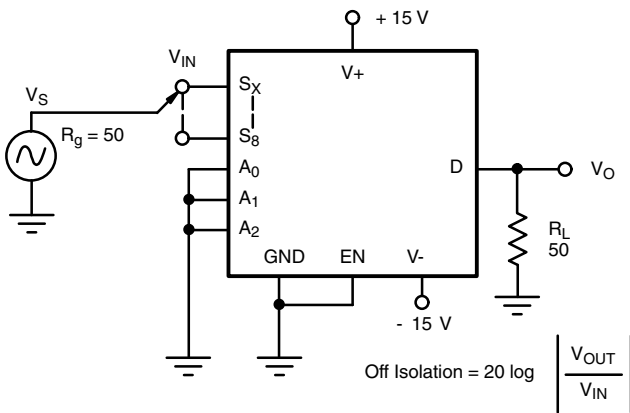

Fig. 5 - Off-Isolation

$$\text{Off Isolation} = 20 \log \left| \frac{V_{\text{OUT}}}{V_{\text{IN}}} \right|$$

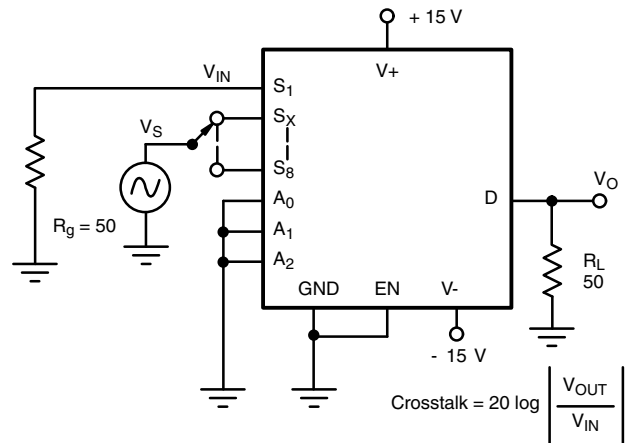
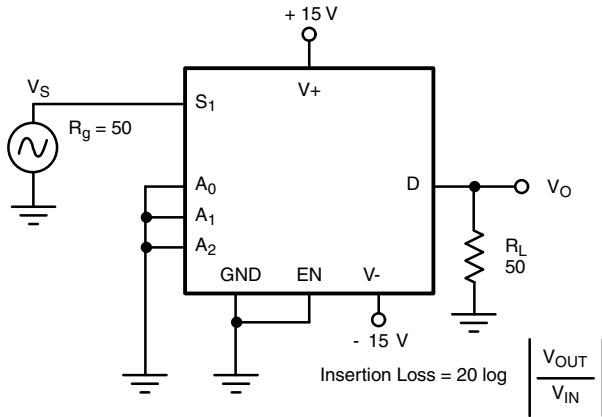
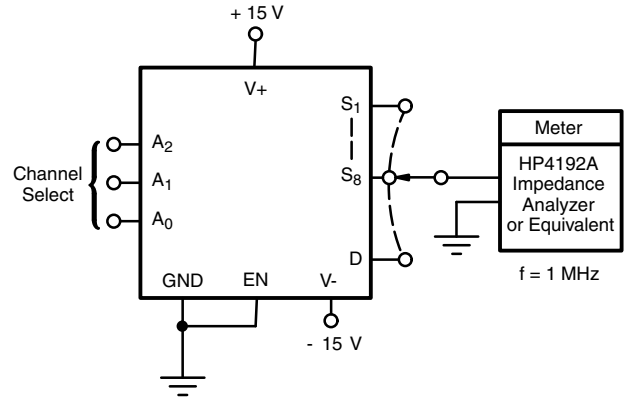

Fig. 6 - Crosstalk

$$\text{Crosstalk} = 20 \log \left| \frac{V_{\text{OUT}}}{V_{\text{IN}}} \right|$$

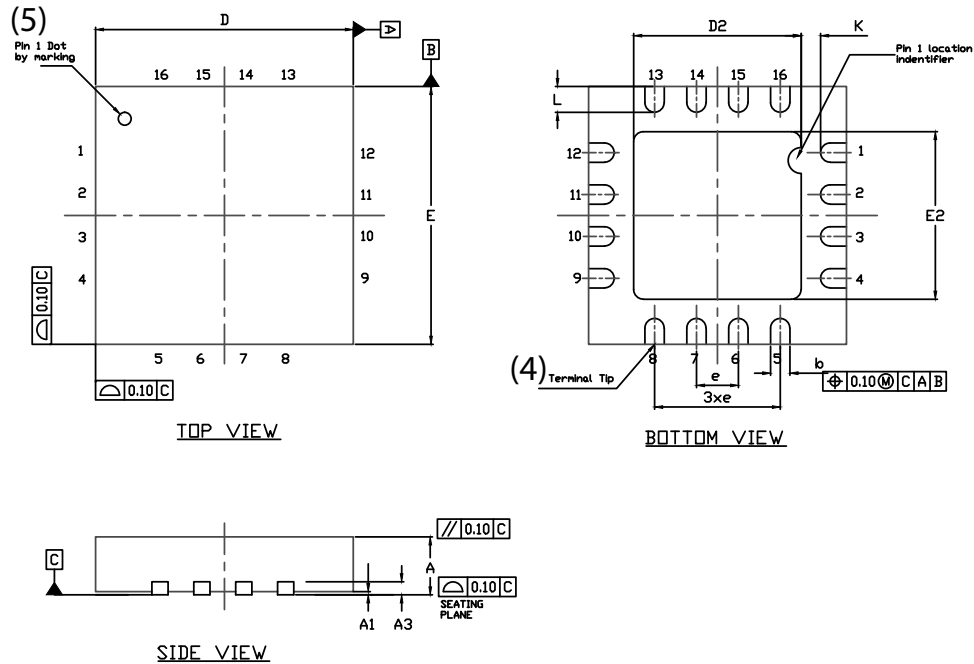

Fig. 7 - Insertion Loss

Fig. 8 - Source Drain Capacitance



PRODUCT SUMMARY		
Part number	DG1408E	DG1409E
Status code	2	2
Configuration	8:1 x 1	4:1 x 2
Single supply min. (V)	4.5	4.5
Single supply max. (V)	24	24
Dual supply min. (V)	4.5	4.5
Dual supply max. (V)	16.5	16.5
On-resistance (Ω)	3.9	3.9
Charge injection (pC)	-31	-103
Source on capacitance (pF)	-	-
Source off capacitance (pF)	13	13
Leakage switch on typ. (nA)	0.05	0.05
Leakage switch off max. (nA)	0.55	0.55
-3 dB bandwidth (MHz)	55	90
Package	QFN-16 4 x 4	QFN-16 4 x 4
Functional circuit / applications	Multi purpose, instrumentation, medical and healthcare	Multi purpose, instrumentation, medical and healthcare
Interface	Parallel	Parallel
Single supply operation	Yes	Yes
Dual supply operation	Yes	Yes
Turn on time max. (ns)	130	130
Crosstalk and off isolation	-58	-58

Vishay Siliconix maintains worldwide manufacturing capability. Products may be manufactured at one of several qualified locations. Reliability data for Silicon Technology and Package Reliability represent a composite of all qualified locations. For related documents such as package/tape drawings, part marking, and reliability data, see www.vishay.com/ppg?76516.

QFN 4x4-16L Case Outline



DIM	VARIATION 1						VARIATION 2					
	MILLIMETERS ⁽¹⁾			INCHES			MILLIMETERS ⁽¹⁾			INCHES		
	MIN.	NOM.	MAX.	MIN.	NOM.	MAX.	MIN.	NOM.	MAX.	MIN.	NOM.	MAX.
A	0.75	0.85	0.95	0.029	0.033	0.037	0.75	0.85	0.95	0.029	0.033	0.037
A1	0	-	0.05	0	-	0.002	0	-	0.05	0	-	0.002
A3	0.20 ref.			0.008 ref.			0.20 ref.			0.008 ref.		
b	0.25	0.30	0.35	0.010	0.012	0.014	0.25	0.30	0.35	0.010	0.012	0.014
D	4.00 BSC			0.157 BSC			4.00 BSC			0.157 BSC		
D2	2.0	2.1	2.2	0.079	0.083	0.087	2.5	2.6	2.7	0.098	0.102	0.106
e	0.65 BSC			0.026 BSC			0.65 BSC			0.026 BSC		
E	4.00 BSC			0.157 BSC			4.00 BSC			0.157 BSC		
E2	2.0	2.1	2.2	0.079	0.083	0.087	2.5	2.6	2.7	0.098	0.102	0.106
K	0.20 min.			0.008 min.			0.20 min.			0.008 min.		
L	0.5	0.6	0.7	0.020	0.024	0.028	0.3	0.4	0.5	0.012	0.016	0.020
N ⁽³⁾	16			16			16			16		
Nd ⁽³⁾	4			4			4			4		
Ne ⁽³⁾	4			4			4			4		

Notes

- (1) Use millimeters as the primary measurement.
- (2) Dimensioning and tolerances conform to ASME Y14.5M. - 1994.
- (3) N is the number of terminals. Nd and Ne is the number of terminals in each D and E site respectively.
- (4) Dimensions b applies to plated terminal and is measured between 0.15 mm and 0.30 mm from terminal tip.
- (5) The pin 1 identifier must be existed on the top surface of the package by using identification mark or other feature of package body.
- (6) Package warpage max. 0.05 mm.

ECN: S13-0893-Rev. B, 22-Apr-13
 DWG: 5890



Disclaimer

ALL PRODUCT, PRODUCT SPECIFICATIONS AND DATA ARE SUBJECT TO CHANGE WITHOUT NOTICE TO IMPROVE RELIABILITY, FUNCTION OR DESIGN OR OTHERWISE.

Vishay Intertechnology, Inc., its affiliates, agents, and employees, and all persons acting on its or their behalf (collectively, "Vishay"), disclaim any and all liability for any errors, inaccuracies or incompleteness contained in any datasheet or in any other disclosure relating to any product.

Vishay makes no warranty, representation or guarantee regarding the suitability of the products for any particular purpose or the continuing production of any product. To the maximum extent permitted by applicable law, Vishay disclaims (i) any and all liability arising out of the application or use of any product, (ii) any and all liability, including without limitation special, consequential or incidental damages, and (iii) any and all implied warranties, including warranties of fitness for particular purpose, non-infringement and merchantability.

Statements regarding the suitability of products for certain types of applications are based on Vishay's knowledge of typical requirements that are often placed on Vishay products in generic applications. Such statements are not binding statements about the suitability of products for a particular application. It is the customer's responsibility to validate that a particular product with the properties described in the product specification is suitable for use in a particular application. Parameters provided in datasheets and / or specifications may vary in different applications and performance may vary over time. All operating parameters, including typical parameters, must be validated for each customer application by the customer's technical experts. Product specifications do not expand or otherwise modify Vishay's terms and conditions of purchase, including but not limited to the warranty expressed therein.

Hyperlinks included in this datasheet may direct users to third-party websites. These links are provided as a convenience and for informational purposes only. Inclusion of these hyperlinks does not constitute an endorsement or an approval by Vishay of any of the products, services or opinions of the corporation, organization or individual associated with the third-party website. Vishay disclaims any and all liability and bears no responsibility for the accuracy, legality or content of the third-party website or for that of subsequent links.

Vishay products are not designed for use in life-saving or life-sustaining applications or any application in which the failure of the Vishay product could result in personal injury or death unless specifically qualified in writing by Vishay. Customers using or selling Vishay products not expressly indicated for use in such applications do so at their own risk. Please contact authorized Vishay personnel to obtain written terms and conditions regarding products designed for such applications.

No license, express or implied, by estoppel or otherwise, to any intellectual property rights is granted by this document or by any conduct of Vishay. Product names and markings noted herein may be trademarks of their respective owners.