

## Power SMD LED PLCC-4

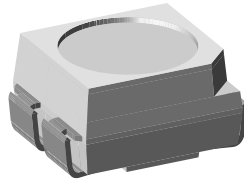

19210\_1

### DESCRIPTION

The VLMW320.. white LED is an advanced product in terms of heat dissipation.

The leadframe profile of this PLCC-4 SMD package is optimized to reduce the thermal resistance.

This allows higher drive current and doubles the light output compared to Vishay's high intensity SMD LED in PLCC-2 standard package.

### PRODUCT GROUP AND PACKAGE DATA

- Product group: LED
- Package: SMD PLCC-4
- Product series: power
- Angle of half intensity:  $\pm 60^\circ$

### FEATURES

- High efficient INGaN technology
- Available in 8 mm tape
- Luminous intensity, color and forward voltage categorized per packing unit
- Luminous intensity ratio per packing unit  $I_{Vmax}/I_{Vmin.} \leq 1.6$
- ESD class 1
- Suitable for all soldering methods according to CECC
- Lead (Pb)-free device
- Preconditioning: according to JEDEC level 2a



### APPLICATIONS

- Interior and exterior lighting
- Indicator and backlighting purposes for audio, video, LCD's switches, symbols, illuminated advertising etc.
- Illumination purpose, alternative to incandescent lamps
- General use

### PARTS TABLE

PART	COLOR, LUMINOUS INTENSITY	TECHNOLOGY WAVELENGTH
VLMW3200-GS08	White, $I_V \geq 560$ mcd (typ 900 mcd)	INGaN/TAG in SiC
VLMW3201-GS08	White, $I_V \geq 710$ mcd	INGaN/TAG in SiC



ABSOLUTE MAXIMUM RATINGS <sup>1)</sup> VLMW320.				
PARAMETER	TEST CONDITION	SYMBOL	VALUE	UNIT
Reverse voltage <sup>2)</sup>		$V_R$	5	V
DC Forward current	$T_{amb} \leq 65\text{ }^\circ\text{C}$	$I_F$	30	mA
Surge forward current	$t_p \leq 10\text{ }\mu\text{s}$	$I_{FSM}$	0.1	A
Power dissipation		PV	127	mW
Junction temperature		$T_j$	100	$^\circ\text{C}$
Operating temperature range		$T_{amb}$	- 40 to + 100	$^\circ\text{C}$
Storage temperature range		$T_{stg}$	- 40 to + 100	$^\circ\text{C}$
Soldering temperature	$t \leq 5\text{ s}$	$T_{sd}$	260	$^\circ\text{C}$
Thermal resistance junction/ambient	mounted on PC board (pad design see page 6)	$R_{thJA}$	270	K/W

Note:

<sup>1)</sup>  $T_{amb} = 25\text{ }^\circ\text{C}$ , unless otherwise specified

<sup>2)</sup> Driving the LED in reverse direction is suitable for a short term application

OPTICAL AND ELECTRICAL CHARACTERISTICS <sup>1)</sup> VLMW320., WHITE							
PARAMETER	TEST CONDITION	PART	SYMBOL	MIN.	TYP.	MAX.	UNIT
Luminous intensity <sup>2)</sup>	$I_F = 30\text{ mA}$	VLMW3200	$I_V$	560			mcd
		VLMW3201	$I_V$	710	900		mcd
Chromaticity coordinate x, y acc. to CIE 1931	$I_F = 30\text{ mA}$	VLMW320.	x y		0.33 0.33		
Angle of half intensity	$I_F = 30\text{ mA}$		$\varphi$		$\pm 60$		deg
Forward voltage	$I_F = 30\text{ mA}$		$V_F$		3.7	4.2	V
Reverse voltage	$I_R = 10\text{ }\mu\text{A}$		$V_R$	5			V
Temperature coefficient of $V_F$	$I_F = 20\text{ mA}$		$TC_{VF}$		- 4		mV/K
Temperature coefficient of $I_V$	$I_F = 20\text{ mA}$		$TC_{IV}$		- 0.5		%/K

Note:

<sup>1)</sup>  $T_{amb} = 25\text{ }^\circ\text{C}$ , unless otherwise specified

<sup>2)</sup> In one Packing Unit  $I_{Vmax}/I_{Vmin} \leq 1.6$

LUMINOUS INTENSITY CLASSIFICATION			
GROUP	LIGHT INTENSITY (mcd)		
	STANDARD	MIN.	MAX.
U2	560	710	
V1	710	900	
V2	900	1120	
AA	1120	1400	
AB	1400	1800	
BA	1800	2240	
BB	2240	2800	

Note:

Luminous intensity is tested at a current pulse duration of 25 ms and an accuracy of  $\pm 11\%$ .

The above type numbers represent the order groups which include only a few brightness groups. Only one group will be shipped on each reel (there will be no mixing of two groups on each reel).

In order to ensure availability, single brightness groups will not be orderable.

In a similar manner for colors where wavelength groups are measured and binned, single wavelength groups will be shipped on any one reel.

In order to ensure availability, single wavelength groups will not be orderable.

CROSSING TABLE		
VISHAY	OSRAM	NICHIA
VLMW3200	LWE67C-U2V2	NSCW021T
VLMW3201	LWE67C-V1V2	NSCW021T

CHROMATICITY COORDINATED GROUPS FOR WHITE SMD LED					
	X	Y		X	Y
5L	0.291	0.268		7L	0.330
	0.285	0.279			0.330
	0.307	0.312			0.347
	0.310	0.297			0.352
5K	0.296	0.259		7K	0.330
	0.291	0.268			0.330
	0.310	0.297			0.338
	0.313	0.284			0.352
6L	0.310	0.297		8L	0.345
	0.307	0.312			0.347
	0.330	0.347			0.367
	0.330	0.330			0.364
6K	0.313	0.284		8K	0.352
	0.310	0.297			0.338
	0.330	0.330			0.364
	0.330	0.310			0.360

Note:  
Chromaticity coordinate groups are tested at a current pulse duration of 25 ms and a tolerance of  $\pm 0.01$ .

**TYPICAL CHARACTERISTICS**

$T_{amb} = 25\text{ }^{\circ}\text{C}$ , unless otherwise specified

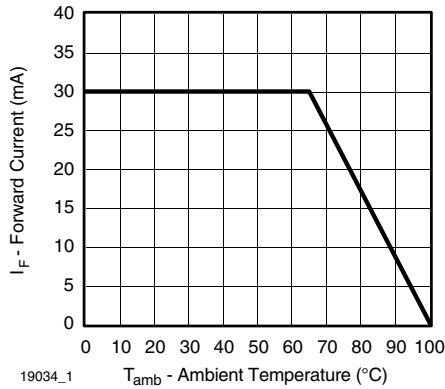

Figure 1. Forward Current vs. Ambient Temperature

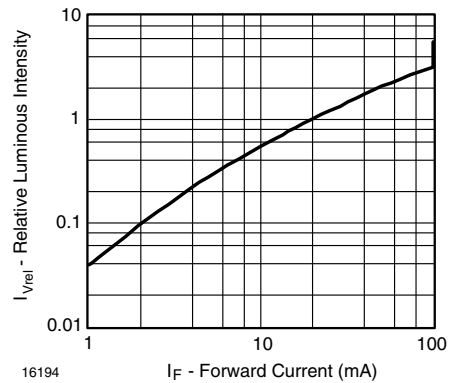

Figure 2. Relative Luminous Intensity vs. Forward Current

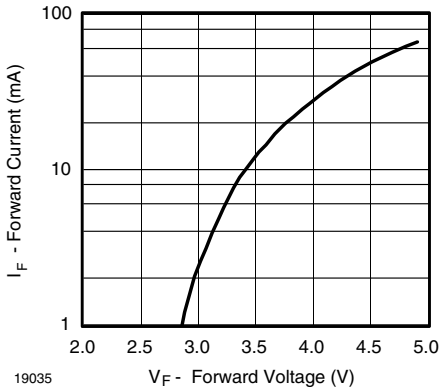

Figure 3. Forward Current vs. Forward Voltage

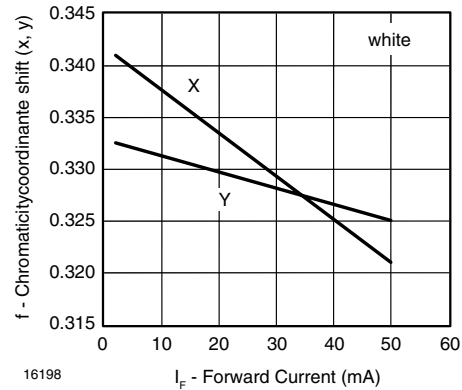

Figure 6. Chromaticity Coordinate Shift vs. Forward Current

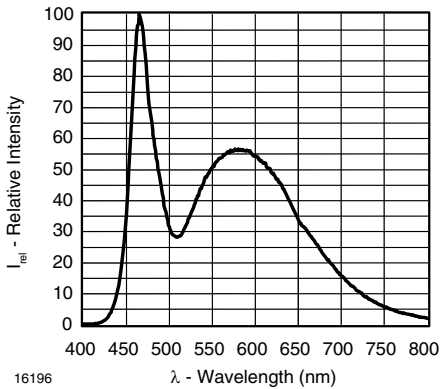

Figure 4. Relative Intensity vs. Wavelength

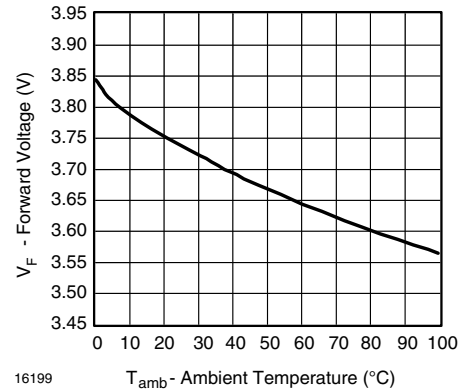

Figure 7. Forward Voltage vs. Ambient Temperature

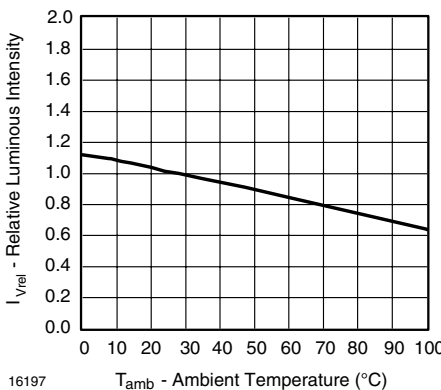

Figure 5. Relative Luminous Intensity vs. Ambient Temperature

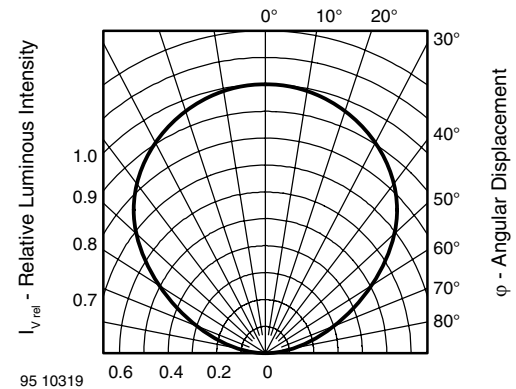

Figure 8. Relative Luminous Intensity vs. Angular Displacement

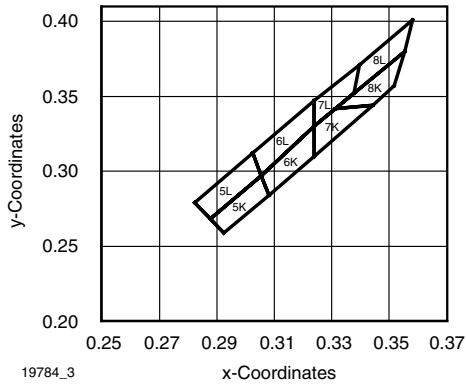

Figure 9. White Grouping SMD

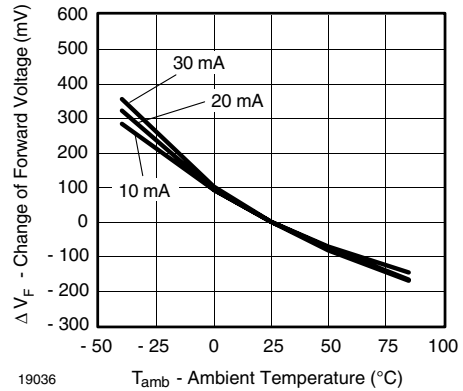
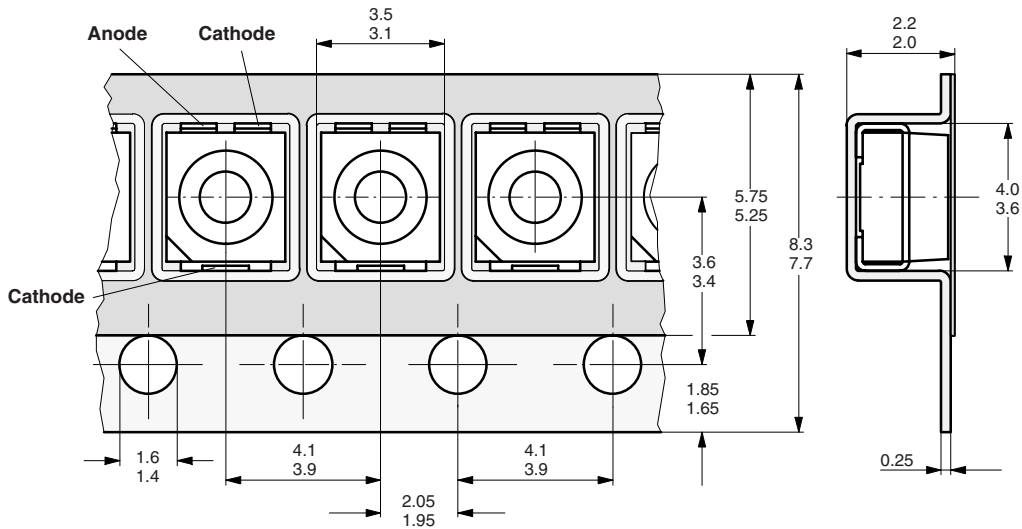

Figure 10. Change of Forward Voltage vs. Ambient Temperature

**TAPING** Dimensions in millimeters



18596

**RECOMMENDED PAD DESIGN** Dimensions in millimeters  
 (Wave-soldering),  $R_{THJA} = 270 \text{ K/W}$

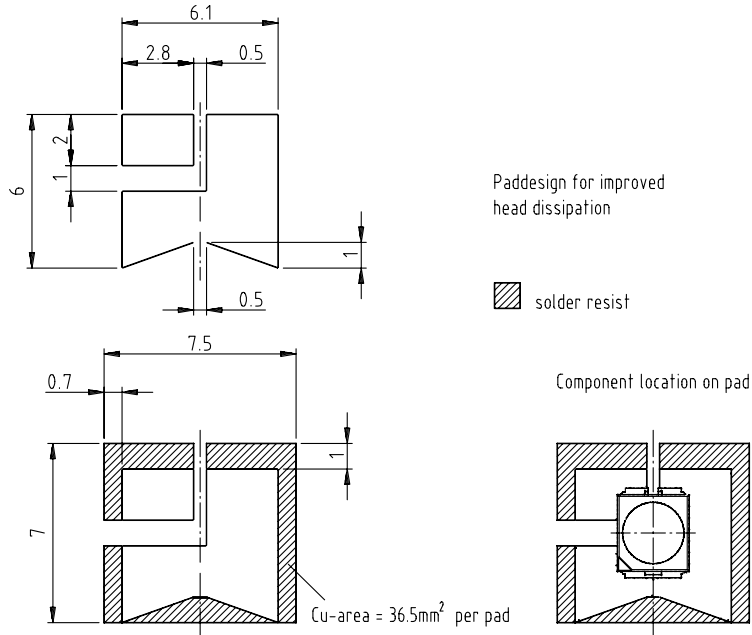

**RECOMMENDED PAD DESIGN** Dimensions in millimeters  
 (Reflow-soldering),  $R_{THJA} = 270 \text{ K/W}$

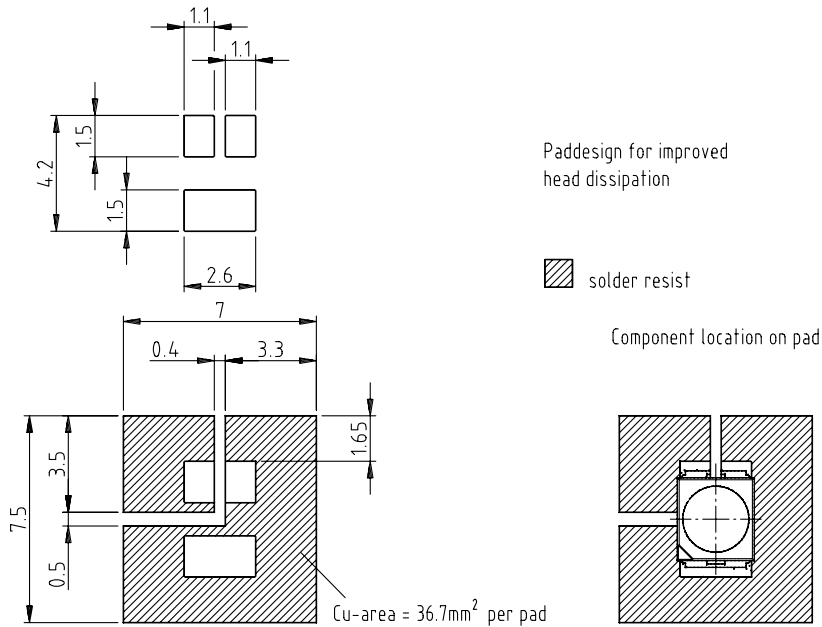

**OPTIONAL PAD DESIGN** Dimensions in millimeters  
(Wave-soldering),  $R_{THJA} = 290 \text{ K/W}$

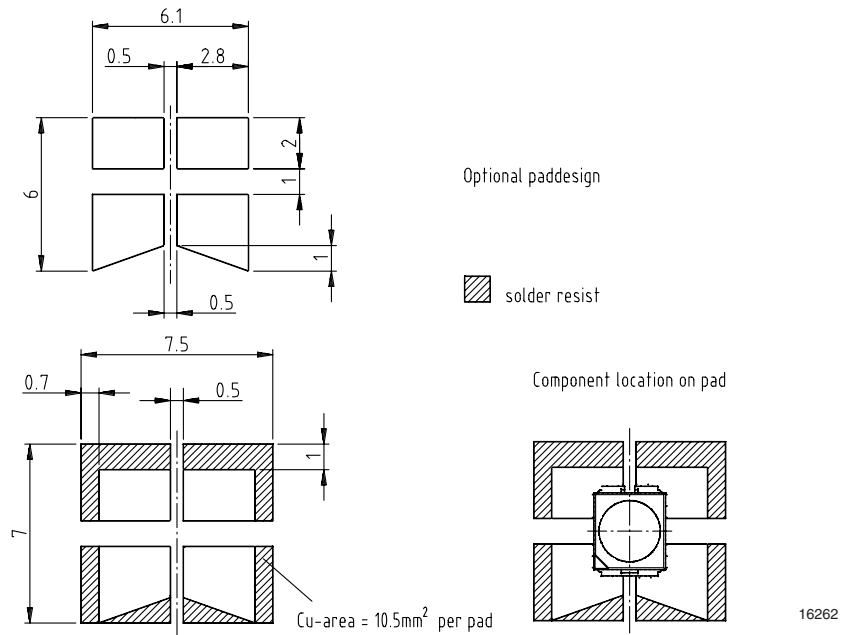

**OPTIONAL PAD DESIGN** Dimensions in millimeters  
(Reflow-soldering),  $R_{THJA} = 290 \text{ K/W}$

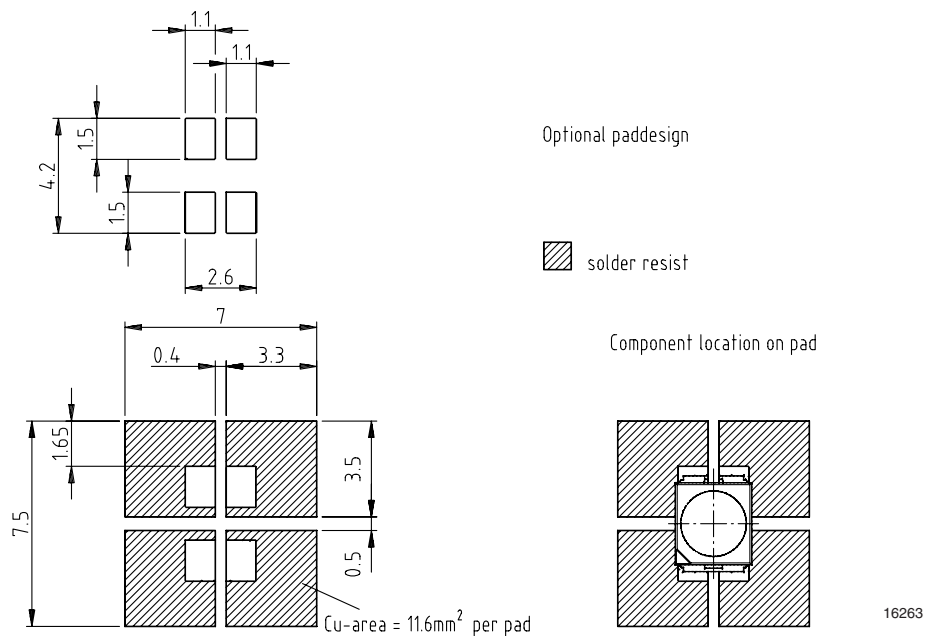

**PACKAGE DIMENSIONS** in millimeters

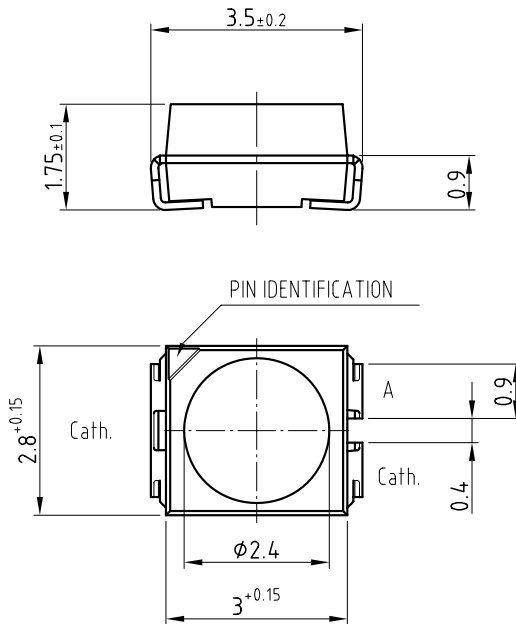

technical drawings according to DIN specifications

**Mounting Pad Layout**

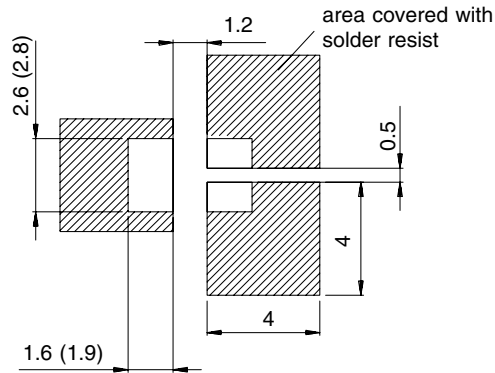

Dimensions: IR and Vaporphase (Wave soldering)

Drawing-No. : 6.541-5054.01-4  
Issue: 3; 31.03.08  
16276\_1

**METHOD OF TAPING/POLARITY AND TAPE AND REEL**

**SMD LED (VLM.3-SERIES)**

Vishay's LEDs in SMD packages are available in an antistatic 8 mm blister tape (in accordance with DIN IEC 40 (CO) 564) for automatic component insertion. The blister tape is a plastic strip with impressed component cavities, covered by a top tape.

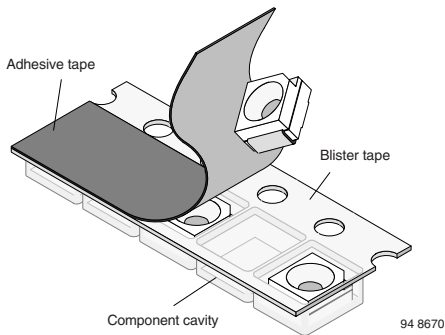

**TAPING OF VLM.3...**

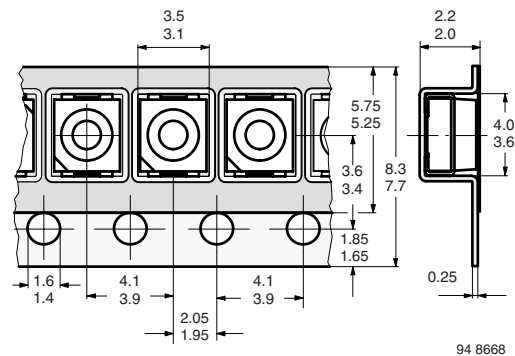

Figure 11. Tape Dimensions in mm for PLCC-2

**REEL PACKAGE DIMENSION IN MILLIMETERS  
FOR SMD LEDs, TAPE OPTION GS08  
(= 1500 PCS.)**

Figure 12. Reel Dimensions - GS08

**BAR CODE PRODUCT LABEL  
EXAMPLE:**

**SOLDERING PROFILE**

 Figure 13. Vishay Lead (Pb)-free Reflow Soldering Profile  
(acc. to J-STD-020C)

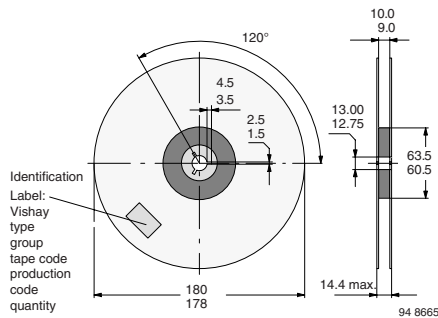
Figure 14. Double Wave Soldering of Opto Devices (all Packages)

- A) Type of component
- B) Manufacturing plant
- C) SEL - selection code (bin):  
e.g.: V1 = code for luminous intensity group  
5L = code for chrom. coordinate group
- D) Date code year/week
- E) Day code (e. g. 1: Monday)
- F) Batch no.
- G) Total quantity
- H) Company code

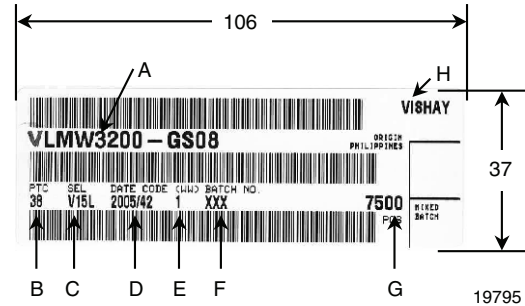
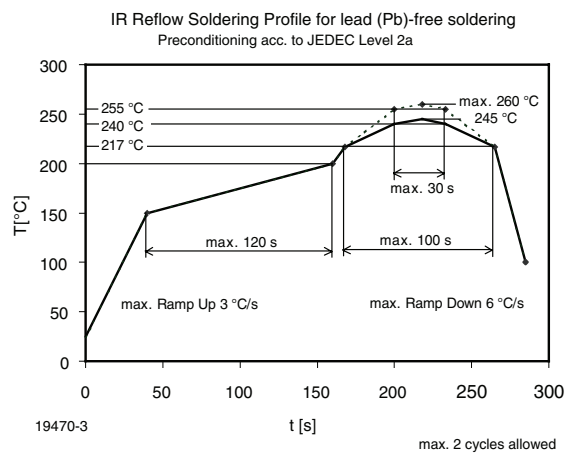
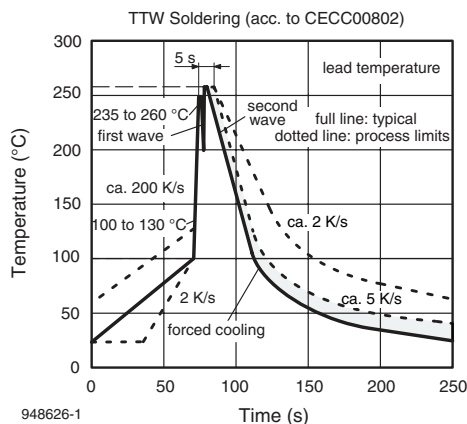
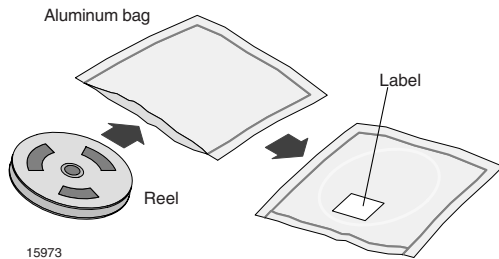
**DRY PACKING**

The reel is packed in an anti-humidity bag to protect the devices from absorbing moisture during transportation and storage.



**FINAL PACKING**

The sealed reel is packed into a cardboard box. A secondary cardboard box is used for shipping purposes.

**RECOMMENDED METHOD OF STORAGE**

Dry box storage is recommended as soon as the aluminum bag has been opened to prevent moisture absorption. The following conditions should be observed, if dry boxes are not available:

- Storage temperature 10 °C to 30 °C
- Storage humidity ≤ 60 % RH max.

After more than 672 h under these conditions moisture content will be too high for reflow soldering.

In case of moisture absorption, the devices will recover to the former condition by drying under the following condition:

192 h at 40 °C + 5 °C/- 0 °C and < 5 % RH (dry air/nitrogen) or

96 h at 60 °C + 5 °C and < 5 % RH for all device containers or

24 h at 100 °C + 5 °C not suitable for reel or tubes.

An EIA JEDEC standard JESD22-A112 level 2a label is included on all dry bags.

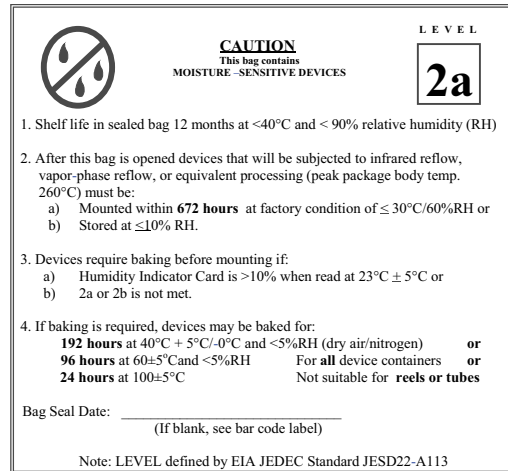

Example of JESD22-A112 level 2a label

**ESD PRECAUTION**

Proper storage and handling procedures should be followed to prevent ESD damage to the devices especially when they are removed from the antistatic shielding bag. Electro-static sensitive devices warning labels are on the packaging.

**OZONE DEPLETING SUBSTANCES POLICY STATEMENT**

It is the policy of Vishay Semiconductor GmbH to

1. Meet all present and future national and international statutory requirements.
2. Regularly and continuously improve the performance of our products, processes, distribution and operating systems with respect to their impact on the health and safety of our employees and the public, as well as their impact on the environment.

It is particular concern to control or eliminate releases of those substances into the atmosphere which are known as ozone depleting substances (ODSs).

The Montreal Protocol (1987) and its London Amendments (1990) intend to severely restrict the use of ODSs and forbid their use within the next ten years. Various national and international initiatives are pressing for an earlier ban on these substances.

Vishay Semiconductor GmbH has been able to use its policy of continuous improvements to eliminate the use of ODSs listed in the following documents.

1. Annex A, B and list of transitional substances of the Montreal Protocol and the London Amendments respectively.
2. Class I and II ozone depleting substances in the Clean Air Act Amendments of 1990 by the Environmental Protection Agency (EPA) in the USA.
3. Council Decision 88/540/EEC and 91/690/EEC Annex A, B and C (transitional substances) respectively.

Vishay Semiconductor GmbH can certify that our semiconductors are not manufactured with ozone depleting substances and do not contain such substances.

We reserve the right to make changes to improve technical design  
and may do so without further notice.

Parameters can vary in different applications. All operating parameters must be validated for each customer application by the customer. Should the buyer use Vishay Semiconductors products for any unintended or unauthorized application, the buyer shall indemnify Vishay Semiconductors against all claims, costs, damages, and expenses, arising out of, directly or indirectly, any claim of personal damage, injury or death associated with such unintended or unauthorized use.

Vishay Semiconductor GmbH, P.O.B. 3535, D-74025 Heilbronn, Germany



## Disclaimer

ALL PRODUCT, PRODUCT SPECIFICATIONS AND DATA ARE SUBJECT TO CHANGE WITHOUT NOTICE TO IMPROVE RELIABILITY, FUNCTION OR DESIGN OR OTHERWISE.

Vishay Intertechnology, Inc., its affiliates, agents, and employees, and all persons acting on its or their behalf (collectively, "Vishay"), disclaim any and all liability for any errors, inaccuracies or incompleteness contained in any datasheet or in any other disclosure relating to any product.

Vishay makes no warranty, representation or guarantee regarding the suitability of the products for any particular purpose or the continuing production of any product. To the maximum extent permitted by applicable law, Vishay disclaims (i) any and all liability arising out of the application or use of any product, (ii) any and all liability, including without limitation special, consequential or incidental damages, and (iii) any and all implied warranties, including warranties of fitness for particular purpose, non-infringement and merchantability.

Statements regarding the suitability of products for certain types of applications are based on Vishay's knowledge of typical requirements that are often placed on Vishay products in generic applications. Such statements are not binding statements about the suitability of products for a particular application. It is the customer's responsibility to validate that a particular product with the properties described in the product specification is suitable for use in a particular application. Parameters provided in datasheets and/or specifications may vary in different applications and performance may vary over time. All operating parameters, including typical parameters, must be validated for each customer application by the customer's technical experts. Product specifications do not expand or otherwise modify Vishay's terms and conditions of purchase, including but not limited to the warranty expressed therein.

Except as expressly indicated in writing, Vishay products are not designed for use in medical, life-saving, or life-sustaining applications or for any other application in which the failure of the Vishay product could result in personal injury or death. Customers using or selling Vishay products not expressly indicated for use in such applications do so at their own risk and agree to fully indemnify and hold Vishay and its distributors harmless from and against any and all claims, liabilities, expenses and damages arising or resulting in connection with such use or sale, including attorneys fees, even if such claim alleges that Vishay or its distributor was negligent regarding the design or manufacture of the part. Please contact authorized Vishay personnel to obtain written terms and conditions regarding products designed for such applications.

No license, express or implied, by estoppel or otherwise, to any intellectual property rights is granted by this document or by any conduct of Vishay. Product names and markings noted herein may be trademarks of their respective owners.

## Material Category Policy

**Vishay Intertechnology, Inc. hereby certifies that all its products that are identified as RoHS-Compliant fulfill the definitions and restrictions defined under Directive 2011/65/EU of The European Parliament and of the Council of June 8, 2011 on the restriction of the use of certain hazardous substances in electrical and electronic equipment (EEE) - recast, unless otherwise specified as non-compliant.**

**Please note that some Vishay documentation may still make reference to RoHS Directive 2002/95/EC. We confirm that all the products identified as being compliant to Directive 2002/95/EC conform to Directive 2011/65/EU.**