

Test and Measurement Methods on Zener Diodes

Introduction

The main feature of a Zener Diode is to give a threshold voltage, clamped to a fixed voltage. The bias current necessary for the function of the component will conduct to dissipate power. By dissipating this power, the junction will increase the junction temperature. Then some care must be paid before using such kind of devices by taking in account their thermal coefficient and thermal resistance which will have influence on the electrical function itself and the life duration of the diode. See also the application note "Breakdown voltage (Zener Voltage) Measurements on Zener Diodes".

Three common methods are briefly described below:

A) When using a Zener Diode inside an application, most of the time this component is used as a voltage stabilizer meaning that the device is biased with a DC current. Measuring the Zener Breakdown voltage is simply operated with a current source and a Voltmeter as follow on figure1.

It is recommended to use calibrated equipment to avoid any risk of mistake. The setting of the current source will be equal to the value I_z or I_{zt} given by the data book of the concerned device. The measurement must be done after the complete stabilizing of the device, in normal case 90 s after the start of the power on. This time can be reduced to 30 s for the lower Zener values from 1 to 10 V. Note that the temperature of the ambient* has also an important influence of the reading, according to its thermal coefficient of Zener voltage. In GS product portfolio, several types of components are specified for a DC current condition, named 'THERMAL EQUILIBRIUM' as for example: 1N5225...1N5267 - MMBZ5225...MMBZ5267 - MMSZ5225...MMSZ5267 - 1N4728...1N4764 - ZM4728...ZM4764 - ZMM5225...ZMM5267

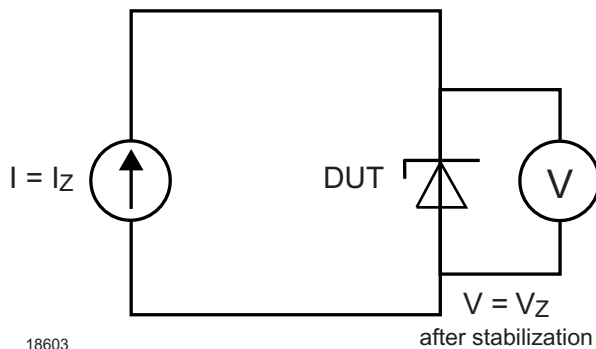

Figure 1.

B) Due to the large volume of components produced per day in General Semiconductor plants, it is commonly used a test pulse from 0,3 ms to 20 ms or more, depending of the type of the device and the parameter to read. The measurement is done by Automatic Test Equipment fitted for such purpose. In this case the ambient* temperature condition is also important because of the thermal coefficient of Zener voltage. In laboratory, this test can simulated by a HF& pulse generator as the source and an oscilloscope for reading the value.

Then the reading of the value will be done only during a short time, smaller than the pulse duration, to avoid any disturbance caused by the rise or the fall ramp. See the figure 2 as principle of the measure. The Zener Diodes are mainly defined by the values tested with a test pulse, specified in the bottom of the table of the data sheets. Because of this short pulse test method, no self-heating of the component is provoked. Thus the final value must be evaluated based on the application conditions.

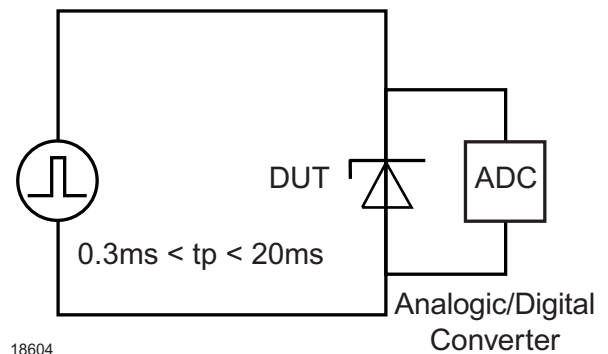
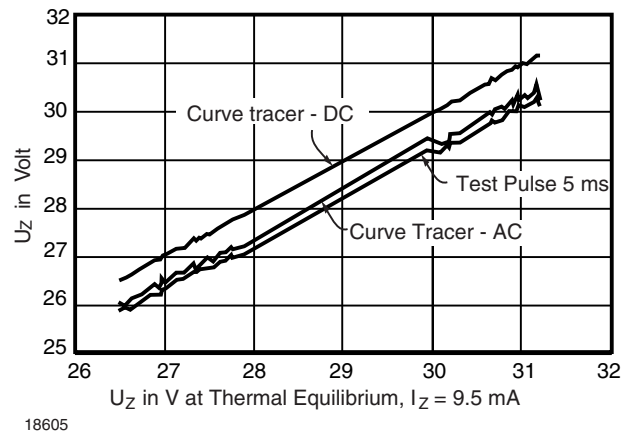

Figure 2.

Vishay Semiconductors

C) Measure on curve tracer is also commonly used to characterize Zener voltage. The main feature of such equipment is to trace a curve V_Z versus I_Z from the specified values choose on the equipment. A particular care must be done about the lecture of the reading, due to the sinus waveform current used to trace the dvz characteristic depending on the d_{iZ} , varying from a low to a bigger value. Measurement of the leakage current in DC condition offers the closer conditions to read a Zener value at thermal equilibrium, however often in a lower range of current than usually given for I_Z in the data sheets. These three test methods give important information about the global behavior of a Zener component, however they are not always compatible. Even of the use of DC condition on the curve tracer, a slight drift is still observed compared to the method of thermal equilibrium. The chart below is given as an example concerning one lot for one type.



18605
Figure 3. 1N4750 Different Test Methods Compared to Thermal Equilibrium

* All methods must be done at a recommended ambient temperature $25\text{ }^{\circ}\text{C} \pm 1$. See also "Breakdown voltage (Zener Voltage) Measurements on Zener Diodes" and "Temperature - Compensated Stabilizing Circuits."

