

True 2 Pin TO-220 FULL-PAK

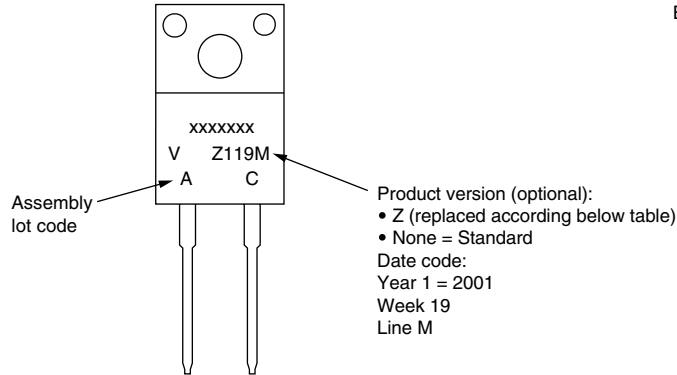

Example: This is a xxxxxxx with assembly lot code AC, assembled on WW 19, 2001 in the assembly line "M"

ENVIRONMENTAL NAMING CODE (Z)	PRODUCT DEFINITION
A	Termination lead (Pb)-free
B	Totally lead (Pb)-free
E	RoHS compliant + termination lead (Pb)-free
F	RoHS compliant + totally lead (Pb)-free
M	Halogen-free + RoHS compliant + termination lead (Pb)-free
N	Halogen-free + RoHS compliant + totally lead (Pb)-free
G	Green