

Wet Tantalum Capacitors, High Energy, Ultra High Capacitance, -55 °C to +125 °C Operation



FEATURES

- High energy, very high capacitance design
- All tantalum, hermetically sealed case
- Utilizes Vishay proven SuperTan® technology
- Terminations: radial leaded
- Approved to DSCC drawing 10011
- Material categorization: for definitions of compliance please see www.vishay.com/doc?99912

RoHS*
Available

Note

* This datasheet provides information about parts that are RoHS-compliant and / or parts that are non RoHS-compliant. For example, parts with lead (Pb) terminations are not RoHS-compliant. Please see the information / tables in this datasheet for details

APPLICATIONS

- Industrial
- Avionics / military / space

PERFORMANCE CHARACTERISTICS

Operating Temperature:

-55 °C to +85 °C (to +125 °C with voltage derating)

Capacitance Tolerance:

at 120 Hz, +25 °C ± 20 % standard
± 10 % available as special

Contact marketing for availability of 10 % tolerance

DC Leakage Current (DCL Max.):

at +25 °C: leakage current shall not exceed the values listed in the Standard Ratings tables.

Life Test:

capacitors are capable of withstanding a 2000 h life test at a temperature of +85 °C at the applicable rated DC working voltage.

ORDERING INFORMATION								
HE3	C	543	K	025	B	Z	S	S
TYPE	CASE CODE	CAPACITANCE	CAPACITANCE TOLERANCE	DC VOLTAGE RATING AT +85 °C	TERMINATION	RELIABILITY LEVEL	TEMPERATURE	ESR
	See Ratings and Case Codes table	This is expressed in microfarads. The first two digits are the significant figures. The third is the number of zeros to follow.	K = 10 % ⁽¹⁾ M = 20 %	This is expressed in V. To complete the three-digit block, zeros precede the voltage rating. A decimal point is indicated by an "R" (6R3 = 6.3 V)	A = 100 % tin (RoHS-compliant) B = tin / lead	Z = non-ER	S = standard (-55 °C to +85 °C)	S = standard

Note

⁽¹⁾ Contact marketing for availability of 10 % tolerance

DIMENSIONS in inches [millimeters]

0.0253 ± 0.002 [0.64 ± 0.05] dia.
(No. 22 AWG) tinned nickel leads
solderable and weldable

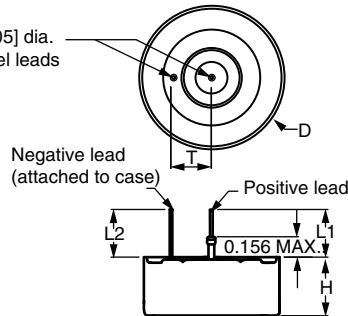

CASE CODE	D	HEIGHT	L2 (MIN.)	L1 (MIN.)	T	WEIGHT (g) (TYPICAL)
TYPE HE3						
A	1.400 ± 0.005 [35.56 ± 0.127]	0.350 ± 0.015 [8.89 ± 0.381]	0.500 [12.70]	0.500 [12.70]	0.40 ± 0.015 [10.2 ± 0.38]	48.0
B	1.400 ± 0.005 [35.56 ± 0.127]	0.488 ± 0.015 [12.395 ± 0.381]	0.500 [12.70]	0.500 [12.70]	0.40 ± 0.015 [10.2 ± 0.38]	73.0
C	1.400 ± 0.005 [35.56 ± 0.127]	0.615 ± 0.015 [15.6 ± 0.4]	0.500 [12.70]	0.500 [12.70]	0.40 ± 0.015 [10.2 ± 0.38]	95.0

RATINGS AND CASE CODES

µF	25 V	50 V	63 V	80 V	100 V	125 V
1100						A
1900					A	
2200						B
2900						C ⁽¹⁾
3000				A		
3300						C
3600					B	
3800					B	
4000			A			
4500					C ⁽¹⁾	
5600				B		
5700					C	
6000				B		
7000				C ⁽¹⁾		
8000		A	B			
9000				C		
11 500			C			
12 000			C			
14 500		B				
16 000		B				
18 000	A	C ⁽¹⁾				
24 000	A	C				
36 000	B					
48 000	B					
54 000	C					
72 000	C					

Note

⁽¹⁾ Preliminary rating. Contact marketing for availability



STANDARD RATINGS				
CAPACITANCE (μ F)	CASE CODE	PART NUMBER	MAX. ESR AT +25 °C, 1 kHz (Ω)	MAX. DCL AT +25 °C (μ A)
25 V_{DC} AT +85 °C; 15 V_{DC} AT +125 °C				
18 000	A	HE3A183(1)025(2)(3)(4)(5)	0.050	150
24 000	A	HE3A243(1)025(2)(3)(4)(5)	0.060	150
36 000	B	HE3B363(1)025(2)(3)(4)(5)	0.045	200
48 000	B	HE3B483(1)025(2)(3)(4)(5)	0.045	200
54 000	C	HE3C543(1)025(2)(3)(4)(5)	0.035	300
72 000	C	HE3C723(1)025(2)(3)(4)(5)	0.035	350
50 V_{DC} AT +85 °C; 30 V_{DC} AT +125 °C				
8000	A	HE3A802(1)050(2)(3)(4)(5)	0.075	170
14 500	B	HE3B143(1)050(2)(3)(4)(5)	0.045	270
16 000	B	HE3B163(1)050(2)(3)(4)(5)	0.045	270
18 000	C ⁽¹⁾	HE3C183(1)050(2)(3)(4)(5)	0.035	400
24 000	C	HE3C243(1)050(2)(3)(4)(5)	0.035	400
63 V_{DC} AT +85 °C; 40 V_{DC} AT +125 °C				
4000	A	HE3A402(1)063(2)(3)(4)(5)	0.100	170
8000	B	HE3B802(1)063(2)(3)(4)(5)	0.055	270
11 500	C	HE3C113(1)063(2)(3)(4)(5)	0.035	400
12 000	C	HE3C123(1)063(2)(3)(4)(5)	0.035	400
80 V_{DC} AT +85 °C; 50 V_{DC} AT +125 °C				
3000	A	HE3A302(1)080(2)(3)(4)(5)	0.100	200
5600	B	HE3B562(1)080(2)(3)(4)(5)	0.065	350
6000	B	HE3B602(1)080(2)(3)(4)(5)	0.065	350
7000	C ⁽¹⁾	HE3C702(1)080(2)(3)(4)(5)	0.040	500
9000	C	HE3C902(1)080(2)(3)(4)(5)	0.040	500
100 V_{DC} AT +85 °C; 65 V_{DC} AT +125 °C				
1900	A	HE3A192(1)100(2)(3)(4)(5)	0.085	200
3600	B	HE3B362(1)100(2)(3)(4)(5)	0.065	350
3800	B	HE3B382(1)100(2)(3)(4)(5)	0.065	350
4500	C ⁽¹⁾	HE3C452(1)100(2)(3)(4)(5)	0.050	500
5700	C	HE3C572(1)100(2)(3)(4)(5)	0.050	500
125 V_{DC} AT +85 °C; 85 V_{DC} AT +125 °C				
1100	A	HE3A112(1)125(2)(3)(4)(5)	0.100	200
2200	B	HE3B222(1)125(2)(3)(4)(5)	0.085	350
2900	C ⁽¹⁾	HE3C292(1)125(2)(3)(4)(5)	0.075	500
3300	C	HE3C332(1)125(2)(3)(4)(5)	0.075	500

Notes

- Part number definitions:
 - Standard capacitance tolerance is 20 % or "M". Contact marketing for availability of 10 % or "K"
 - Standard termination is "B" or tin / lead. RoHS-compliant or 100 % tin is available as "A"
 - Standard reliability is "Z" or non-established reliability
 - Standard temperature range is "S" or -55 °C to +125 °C
 - Standard ESR is "S"
- ⁽¹⁾ Preliminary rating, specification subject to change. Contact marketing for availability

**PERFORMANCE CHARACTERISTICS OF HIGH ENERGY CAPACITORS**

ELECTRICAL PERFORMANCE CHARACTERISTICS	
ITEM	PERFORMANCE CHARACTERISTICS
Operating temperature range	-55 °C to +85 °C (to +125 °C with voltage derating)
Storage temperature range	-62 °C to +130 °C
Capacitor tolerance	± 20 % ± 10 % at 120 Hz
ESR	Limits per Standard Ratings table
DC leakage current (DCL max.)	At 25 °C the leakage current shall not exceed values listed in the Standard Rating table.
Reverse voltage	No continuous reverse voltage permitted
Surge voltage	The test shall be at 1000 cycles at 110 % of rated voltage at 85 °C. A cycle consists of a 30 s charge and a 330 s discharge through 100 Ω resistor.
Life test	2000 h at +85 °C

ENVIRONMENTAL CHARACTERISTICS		
ITEM	TEST AND CONDITIONS	COMMENTS
Hermeticity	MIL-STD-202, method 112 C/IIIa	The capacitor shall be hermetically sealed such that the case does not leak electrolyte or vent any gas when exposed to a vacuum.
Moisture resistance	MIL-STD-202, method 106	6 V polarity
Altitude	MIL-STD-202, method 105 C, test condition D	100 000 feet test

MECHANICAL PERFORMANCE CHARACTERISTICS		
ITEM	TEST AND CONDITIONS	COMMENTS
Thermal shock	MIL-STD-202, method 107 G	Test condition A
Shock	MIL-STD-202, method 213 B test condition G	11 ms, 50 g
Vibration - high frequency	MIL-STD-202, method 204 D test condition D	12 sweeps/axis, 20 g peak
Vibration - random	MIL-STD-202, method 214 A test condition I, letter D	1.5 h/axis, 12 g
Resistance to solder heat	MIL-STD-202, method 210 F	The capacitor must withstand solder dipping of the terminals at 260 °C for 10 s. The capacitor must not be visibly damaged and the electrical characteristics must not be affected.
Solderability	MIL-STD-202, method 208	
Terminal strength	MIL-STD-202, method 211 A	The capacitor terminals must withstand a 5 pound pull test for 5 s to 10 s. The capacitor must not be visibly damaged and the electrical characteristics must not be affected.
Part markings	MIL-STD-202, method 215 J	The capacitor shall be permanently and legibly marked on the circumference of the case. The markings shall be resistant to solvents.
Weight (mass)		See dimensions table
Seal	MIL-PRF-39006	
MSL	J-STD-033	Not applicable
Packaging	MIL-PRF-39006	All units are shipped in individual bulk packages

HE3 MOUNTING OPTIONS

The HE3 capacitor can be mounted with many commercially available methods. Vishay offers the optional mounting hardware outlined below.

THROUGH-HOLE

If mounted through-hole, the glass-to-metal seal must be protected from potential mounting and application stress. The HE3 can be mounted termination down through the HE3SPC001 spacer into the PCB. The proper size bracket HE3BKT00* can then be utilized to hold the HE3 rigidly to the PCB.

TERMINATIONS UP

If mounted with terminations facing up for attachment to wiring, the spacer is not needed. The HE3 can be reversed with terminations facing upward through the center of the HE3BKT00* bracket, which is then mounted through the PCB.

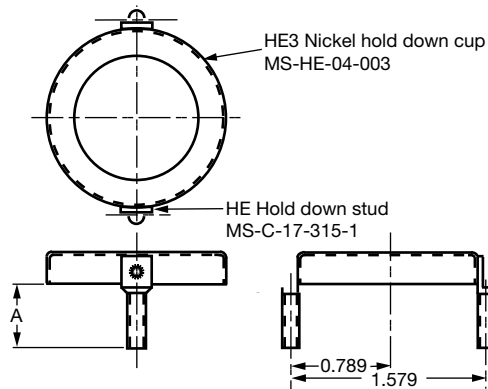

Notes

- Spot weld, 2 places
- Mounting bolt:
 1. Material - stainless steel
 2. Thread - 6-32 NC-2A
- Recommended max. tightening torque on nuts is 48 in-oz (0.34 Nm)

PART NUMBER ⁽¹⁾	STUD	A ± 0.010
HE3BKT001	HE3A	0.391
HE3BKT002	HE3B	0.518
HE3BKT003	HE3C	0.605
HE3BKT004	HE3A W/spacer	0.572
HE3BKT005	HE3B W/spacer	0.699
HE3BKT006	HE3C W/spacer	0.831

Note

⁽¹⁾ The part numbers shown are for ordering the mounting bracket and / or spacer. The HE3 capacitor must be ordered separately using the correct part number as outlined in ORDERING INFORMATION and in the STANDARD RATINGS table

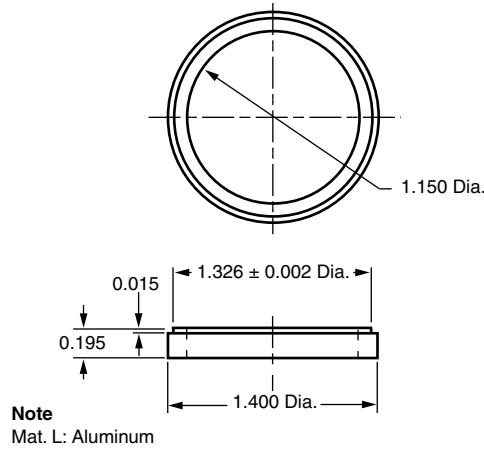

PART NUMBER ⁽¹⁾
HE3SPC001

Note

⁽¹⁾ The part numbers shown are for ordering the mounting bracket and / or spacer. The HE3 capacitor must be ordered separately using the correct part number as outlined in ORDERING INFORMATION and in the STANDARD RATINGS table

HE3 PC BOARD MOUNTED

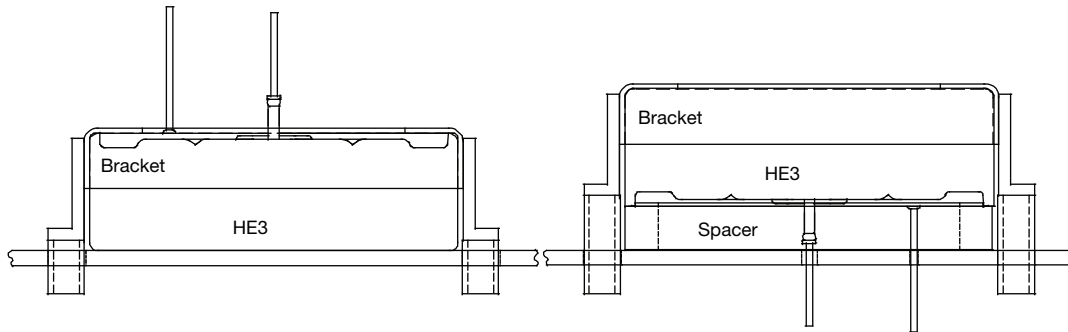



Disclaimer

ALL PRODUCT, PRODUCT SPECIFICATIONS AND DATA ARE SUBJECT TO CHANGE WITHOUT NOTICE TO IMPROVE RELIABILITY, FUNCTION OR DESIGN OR OTHERWISE.

Vishay Intertechnology, Inc., its affiliates, agents, and employees, and all persons acting on its or their behalf (collectively, "Vishay"), disclaim any and all liability for any errors, inaccuracies or incompleteness contained in any datasheet or in any other disclosure relating to any product.

Vishay makes no warranty, representation or guarantee regarding the suitability of the products for any particular purpose or the continuing production of any product. To the maximum extent permitted by applicable law, Vishay disclaims (i) any and all liability arising out of the application or use of any product, (ii) any and all liability, including without limitation special, consequential or incidental damages, and (iii) any and all implied warranties, including warranties of fitness for particular purpose, non-infringement and merchantability.

Statements regarding the suitability of products for certain types of applications are based on Vishay's knowledge of typical requirements that are often placed on Vishay products in generic applications. Such statements are not binding statements about the suitability of products for a particular application. It is the customer's responsibility to validate that a particular product with the properties described in the product specification is suitable for use in a particular application. Parameters provided in datasheets and / or specifications may vary in different applications and performance may vary over time. All operating parameters, including typical parameters, must be validated for each customer application by the customer's technical experts. Product specifications do not expand or otherwise modify Vishay's terms and conditions of purchase, including but not limited to the warranty expressed therein.

Hyperlinks included in this datasheet may direct users to third-party websites. These links are provided as a convenience and for informational purposes only. Inclusion of these hyperlinks does not constitute an endorsement or an approval by Vishay of any of the products, services or opinions of the corporation, organization or individual associated with the third-party website. Vishay disclaims any and all liability and bears no responsibility for the accuracy, legality or content of the third-party website or for that of subsequent links.

Vishay products are not designed for use in life-saving or life-sustaining applications or any application in which the failure of the Vishay product could result in personal injury or death unless specifically qualified in writing by Vishay. Customers using or selling Vishay products not expressly indicated for use in such applications do so at their own risk. Please contact authorized Vishay personnel to obtain written terms and conditions regarding products designed for such applications.

No license, express or implied, by estoppel or otherwise, to any intellectual property rights is granted by this document or by any conduct of Vishay. Product names and markings noted herein may be trademarks of their respective owners.