

Unbalance Monitoring



FEATURES

- Indoor or outdoor version available
- Special design to fit capacitor banks assemblies with IP55 terminal covers

APPLICATIONS

- Monitoring unbalance currents of capacitor banks
 - Double-star connection
 - Bridge connection
- Monitoring unbalance voltages of capacitor banks

QUICK REFERENCE DATA

Type	Unbalance monitoring
Description	Unbalance measuring device for capacitor banks connected in double-star or bridge connection
Rated data	Primary current: 5 A / 10 A / 25 A / 50 A
Current data	One current output: 1 A
Protecting level	IP00

TECHNICAL DATA

Accuracy class	Class 1
VA-rating	1.5 VA
Maximum overload	200 A/1 s
Frequency	50 Hz / 60 Hz
Temperature	-30 °C to +65 °C
Insulation level	12 kV (28 kV / 75 kVp) or 17.5 kV (38 kV / 95 kVp)
Installation	Indoor and outdoor version available

APPLICATION

When a short circuit occurs in the winding element of a capacitor unit, gas can form, causing the capacitor case to swell and eventually burst if left uncontrolled.

A protection relay can be used to detect such faults well in advance. The relay compares the star points of two parallel star connected capacitor arrangements. As soon as there is a voltage shift in one of the star points, an unbalanced current will flow between the two star points. The protection relay can be configured to indicate the fault and disconnect the faulty capacitors when this tripping current goes over a predetermined value.

Capacitor banks arranged in a bridge circuit can also be controlled by the ESTAsym W, which in such cases is connected in the midpoint of the bridge (Fig. 2).

The combination of an ESTAsym W and ESTAsym relay can recognize winding element failure early on and disconnect the capacitor bank before any significant damage occurs.

SETTING OF TRIPPING VALUE

The choice of the appropriate tripping value for the unbalanced current depends on how the capacitors are connected internally and upon the external arrangement of the capacitor bank. Factory recommendations for alarm and / or tripping values as well as time delays are included in the contractual documentation supplied with each capacitor bank at time of delivery.

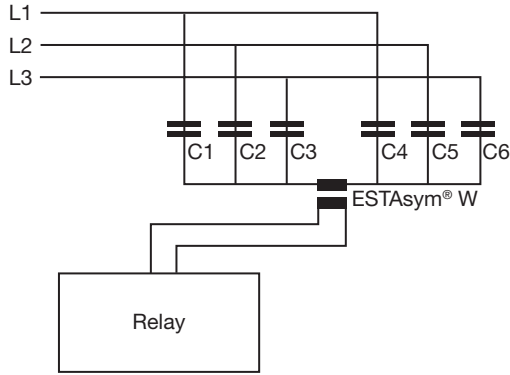

Fig. 1 - Double-star connection

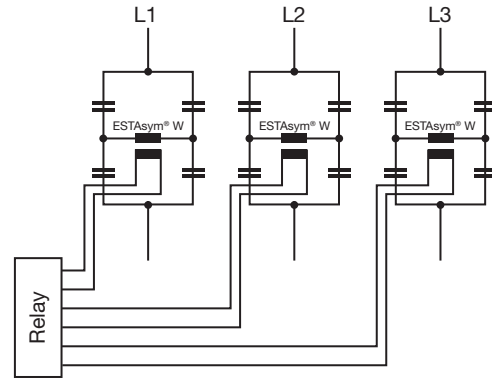

Fig. 2 - Bridge connection

FACTORY TESTS

Because the ESTAsym W is intended exclusively to protect capacitor banks, we use the testing voltages specified by the IEC 60871 standard for capacitors in performing our insulation test for the ESTAsym W. This means that on the basis of insulation class 12 kV or 17.5 kV the primary sides are tested to the secondary side/housing with 28 kV AC/10 s or 38 kV AC/ 10 s respectively. The test of the secondary side to the housing is made with a voltage of 2.5 kV AC for 10 s.

TESTING THE ESTAsym W FOR PROPER FUNCTIONING

For reliable operation, we recommend a regular examination of the complete capacitor protection set-up. The operation of the alarm and trip levels for the protection circuits are best confirmed through primary current injection of the ESTAsym W. Following an alarm or trip operation, the capacitor bank should only be re-energized after it has been thoroughly inspected.

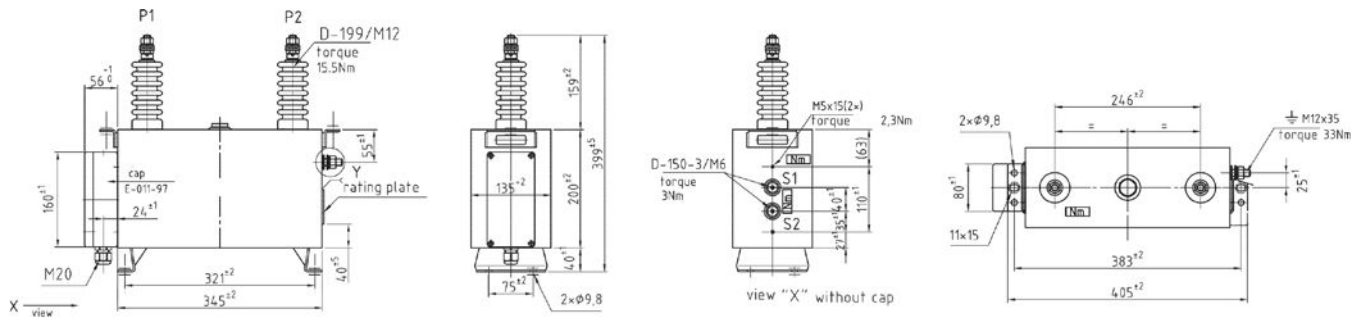

Fig. 3 - Indoor type with bushing D-199

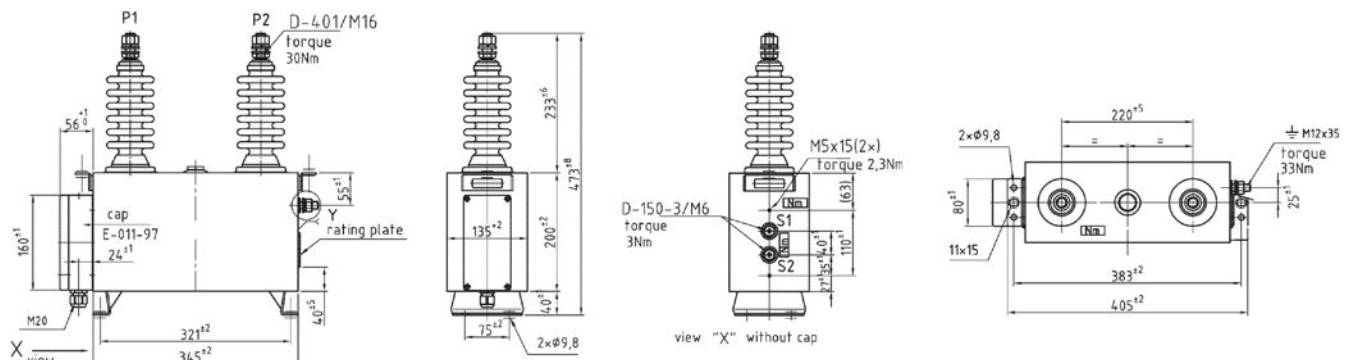

Fig. 4 - Outdoor type with bushing D-401



Disclaimer

ALL PRODUCT, PRODUCT SPECIFICATIONS AND DATA ARE SUBJECT TO CHANGE WITHOUT NOTICE TO IMPROVE RELIABILITY, FUNCTION OR DESIGN OR OTHERWISE.

Vishay Intertechnology, Inc., its affiliates, agents, and employees, and all persons acting on its or their behalf (collectively, "Vishay"), disclaim any and all liability for any errors, inaccuracies or incompleteness contained in any datasheet or in any other disclosure relating to any product.

Vishay makes no warranty, representation or guarantee regarding the suitability of the products for any particular purpose or the continuing production of any product. To the maximum extent permitted by applicable law, Vishay disclaims (i) any and all liability arising out of the application or use of any product, (ii) any and all liability, including without limitation special, consequential or incidental damages, and (iii) any and all implied warranties, including warranties of fitness for particular purpose, non-infringement and merchantability.

Statements regarding the suitability of products for certain types of applications are based on Vishay's knowledge of typical requirements that are often placed on Vishay products in generic applications. Such statements are not binding statements about the suitability of products for a particular application. It is the customer's responsibility to validate that a particular product with the properties described in the product specification is suitable for use in a particular application. Parameters provided in datasheets and / or specifications may vary in different applications and performance may vary over time. All operating parameters, including typical parameters, must be validated for each customer application by the customer's technical experts. Product specifications do not expand or otherwise modify Vishay's terms and conditions of purchase, including but not limited to the warranty expressed therein.

Except as expressly indicated in writing, Vishay products are not designed for use in medical, life-saving, or life-sustaining applications or for any other application in which the failure of the Vishay product could result in personal injury or death. Customers using or selling Vishay products not expressly indicated for use in such applications do so at their own risk. Please contact authorized Vishay personnel to obtain written terms and conditions regarding products designed for such applications.

No license, express or implied, by estoppel or otherwise, to any intellectual property rights is granted by this document or by any conduct of Vishay. Product names and markings noted herein may be trademarks of their respective owners.