

## Reference Design High Voltage Intelligent Battery Shunt



### LINKS TO ADDITIONAL RESOURCES

- [HV-IBSS-USB reference design](#)

### DESCRIPTION

Vishay's HV-IBSS-USB reference design is designed to make evaluation of the WSBE8518 low TCR shunt easy. It uses a single USB-C connector to provide power to the circuit and to emulate a serial interface so the user can conveniently read voltage, current, and temperature readings.

Due to the low [TCR](#) of the WSBE8518 (max.  $\pm 10$  ppm/K for 100  $\mu\Omega$ ), alongside the choice of low thermal drift components in the analog frontend, this reference design is able to achieve an overall TCR of approx. 44 ppm/K max., without thermal compensation, over the whole automotive temperature range. The device is factory-calibrated (values stored in onboard EEPROM) to allow for current measurements with 0.2 % accuracy and thermal drift for currents in the range of  $\pm 500$  A <sup>(1)</sup>.

In serial production and with statistical testing, it seems possible to get the total thermal drift down even further, since opposing thermal drifts in different components were observed during development.

During the development of this reference design it became clear that the main challenge has become finding low thermal drift analog parts, rather than compensating the resistive element.

#### Note

- <sup>(1)</sup> Main contributor to accuracy originates from the calibration process, precision is higher and mainly limited by TCR

### FEATURES

- Versatile
  - USB-C connections for power and data
  - With terminal emulation suited for a wide variety of operating systems
  - Easy to connect to busbar and lugs via M6 screws
- Precise / accurate
  - Factory two-point current calibration: < 0.2 %
  - Max. 10 ppm/K drift due to shunt
  - Approx. max. 34 ppm/K drift due to AFE and ADC

### KEY COMPONENTS

- [WSBE8518 100  \$\mu\Omega\$](#)
- [CDMA2512 50 M \$\Omega\$ , 400:1](#)

### APPLICATIONS

- Industry and automation
- Home automation
- Industrial and server computing
- Networking, telecom, and base station power supplies
- Battery management systems
- EV test environment
- Solar installations

### TYPICAL APPLICATION CIRCUIT

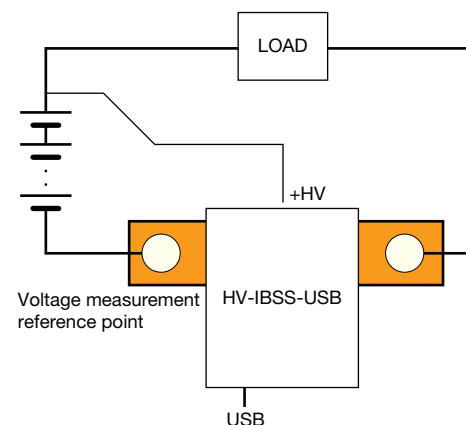

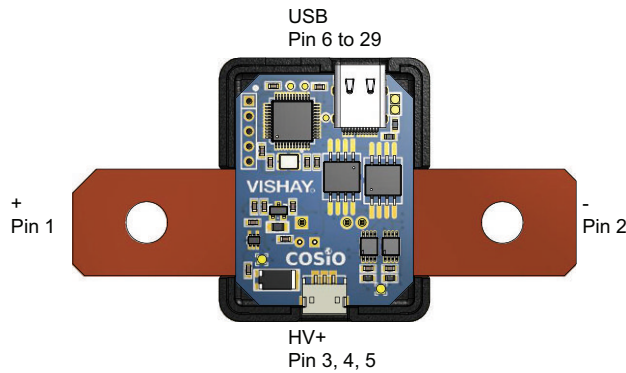
**PIN CONFIGURATION**

PIN DESCRIPTION		
PIN NUMBER	SYMBOL	DESCRIPTION
1	+	Marked with larger chamfer, connect to negative load terminal
2	-	Connect to negative battery terminal, current entering this terminal will be considered positive
3, 4, 5	HV+	Connect to positive battery terminal, only used for voltage measurement, referenced to battery terminal (Pin 2)
6 to 29	USB	USB interface used to supply power and transfer data, use external USB isolator for safety and if you exceed the safe range of the charge pump or isolators used

RECOMMENDED OPERATING RANGE			
PARAMETER	MIN.	MAX.	UNIT
HV + to +	10	850	V

ABSOLUTE MAXIMUM RATINGS ( $T_A = 25\text{ }^\circ\text{C}$ , unless otherwise noted)		
ELECTRICAL PARAMETER	LIMITS	UNIT
HV+ to +	$\pm 1000$	V
HV+, + and - to any USB pin <sup>(1)</sup>	-850 to +850	V
Measured current limits	$\pm 500$	A
Ambient temperature <sup>(2)</sup>	-40 to +75	$^\circ\text{C}$
Storage temperature	-65 to +85	$^\circ\text{C}$
Power dissipation max. power dissipation in shunt	36	W

**Notes**

- <sup>(1)</sup> Use of external USB isolator highly recommended, all high voltage safety precautions should be respected  
<sup>(2)</sup> Derating of the shunt applies

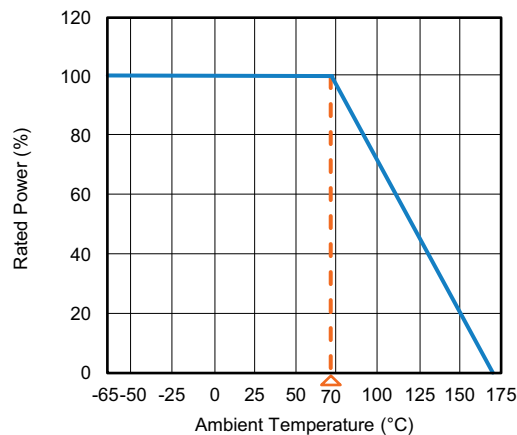
**DERATING**

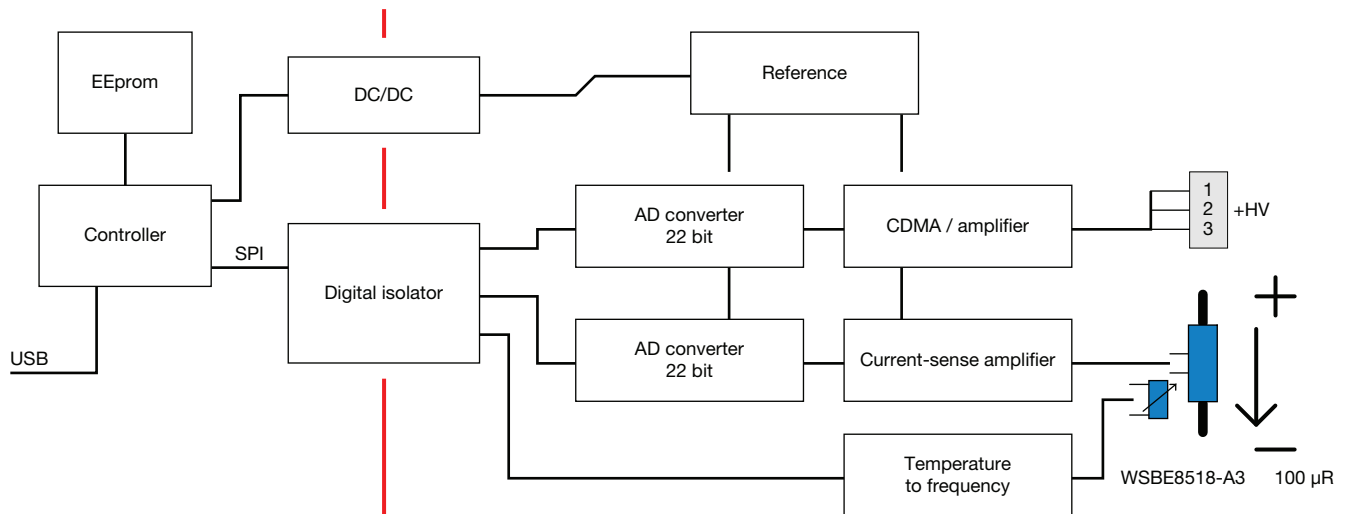
**FUNCTIONAL BLOCK DIAGRAM**

**OPERATIONAL DESCRIPTION**
**Device Overview**

The fundamental structure of this circuit comprises two domains: the high voltage domain (HV) and the low voltage domain (LV), which are isolated from each other.

In the low voltage domain, a microcontroller is attached to both the USB and SPI bus. The USB is used to both supply power as well as for data transfer. A charge pump is used to transfer power to the analog frontend and ADCs, which reside within the HV domain.

To make the most of the shunt's potential, the ADC and its frontend are chosen to maximize resolution (22-bit sigma-delta) while minimizing thermal drift, e.g. through automatic offset and gain calibration. Each function is described in more detail below.

**Current Measurement**

Due to the very low TCR value of the shunt, the bigger part of the drift is contributed to the analog circuitry rather than to the shunt itself.

To match the drift of the shunt, special care has to be taken in component selection.

This reference design is based on a third-order delta-sigma modulator with automatic gain and offset error calibrations to minimize these errors over lifetime and temperature, as well as to offer the highest resolution possible.

For operation, the ADC is supplied by an external reference. A thermal drift in this reference (25 ppm/°C maximum) will directly translate to a drift of the measured values. The third component that influences the measurement is an operational amplifier that amplifies the small voltage drop over the shunt to the input range of the ADC.

Each amplifier has multiple error sources. While the gain error and offset voltage are removed by the two-point current calibration, the offset drift and gain error drift still affect the final measurement.

In this case the operational amplifier's gain drift is 7 ppm/K (maximum) and the offset drift is 80 nV/K (maximum). In relation to the measurement range of 50 mV, this is 1.6 ppm(FS)/K. Under the worst-case assumption that all drifts have the same sign, the max. drift can be approximated as 25 ppm/K + 7 ppm/K + 1.6 ppm/K, totalling to 33.6 ppm/K for the analog circuitry compared to 10 ppm/K for the shunt.

Just by comparing the drift of the voltage reference to the drift of Vishay's low TCR shunts, it becomes obvious that with this new technology the main contributor to thermal drift is not the resistive element but AFE / ADC.

**The challenge for the electrical engineer is no longer to compensate for the TCR of the shunt, but to find analog components that support the low TCR of the shunt.**



Voltage Measurement

Similar to the current measurement, a 22-bit sigma-delta ADC is utilized. The voltage between the HV+ port and the + port of the shunt is divided using a CDMA. This voltage is buffered and fed directly to the ADC. Since the CDMA's, divider ratio is chosen to match the ADC input range, no amplification is necessary. This eliminates the gain drift from the equation so that the main contributors to thermal drift in the voltage measurement are the tracking TCR of the voltage divider, the temperature-dependent offset voltage of the opamp / buffer, and the gain / offset error of the ADC.

Temperature Measurement

To visualize the temperature of the shunt, an NTC and multivibrator are used as a temperature to frequency converter. The PWM signal generated by the analog circuitry is transmitted over the isolation barrier and sensed by the MCU.

Serial Interface

The user can connect the USB cable to any computer they like. After connection to the computer, a USB to serial adapter should be automatically detected (listed as STMicroelectronics Virtual COM port). In case the driver is not automatically detected, try to manually install / use drivers provided by STM.

Once initialized by the system the user can access the virtual COM port with their terminal of choice, e.g. HTERM. Due to the nature of the virtual COM port, there is no specific baud rate setting required.

After initial connection to the COM port, the user will see a blank screen and can interact with the device using the following commands:

SERIAL INTERFACE			
CHARACTER	FUNCTION	ACTION	RETURN VALUE
C	Current	Display most recent current reading	e.g. 200.123 A
V	Voltage	Display most recent voltage reading	e.g. 500.12 V
T	Temperature	Display most recent temperature reading	e.g. 38 °C
R	Repeat	Display current / voltage and temp once per second until a new command is issued	
?	Help	Every unassigned character will display a help	

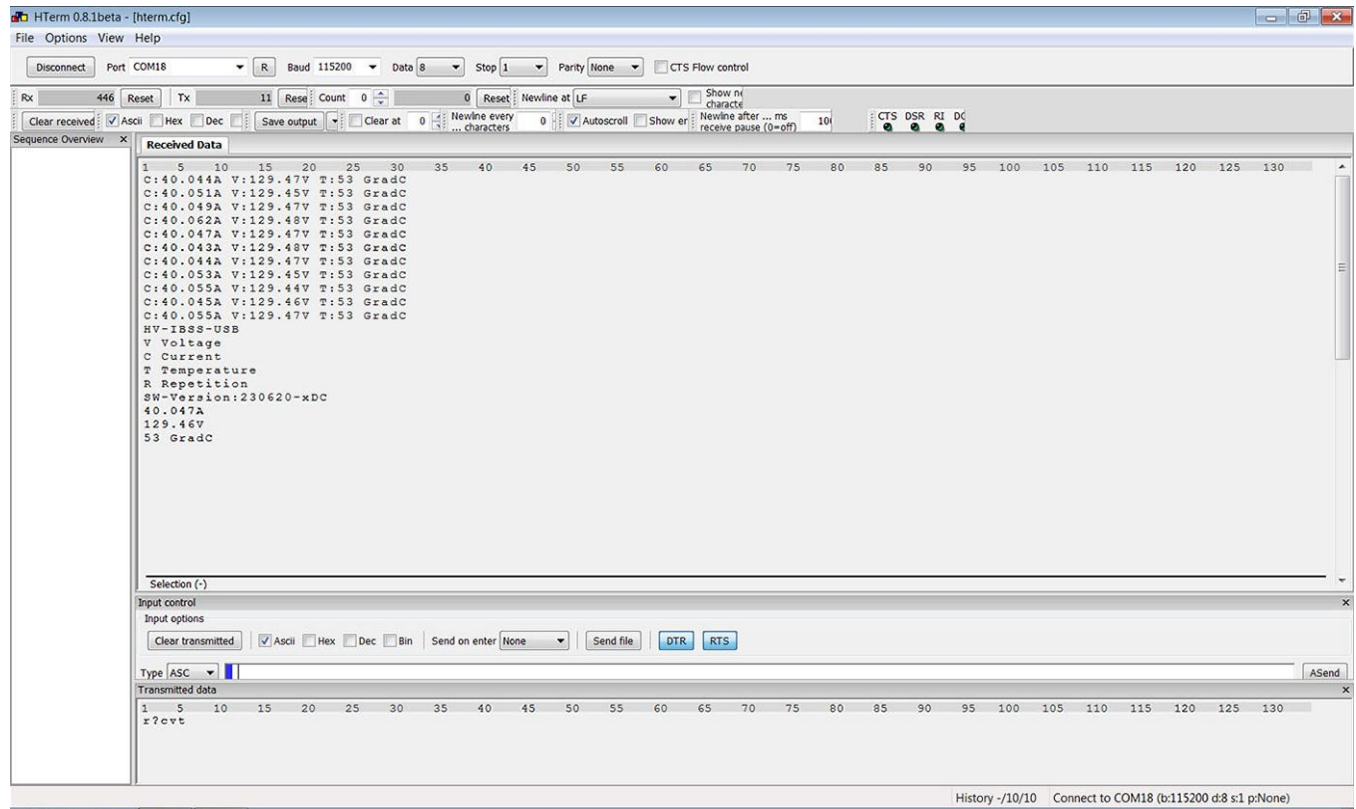



### ELECTRICAL CHARACTERISTICS SYSTEM

( $V_{IN\ USB} = 5\ V$ ,  $I_{shunt} = 200\ A$ ,  $T_A = 27\ ^\circ C$ , values measured on an arbitrary unit unless otherwise noted)

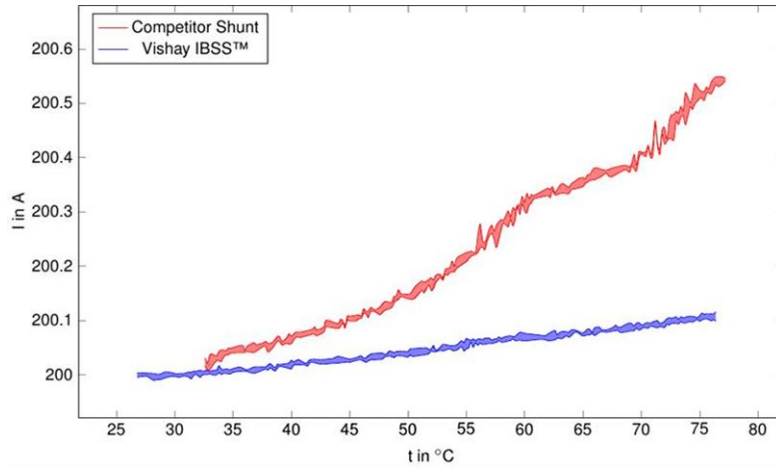

### ELECTRICAL CHARACTERISTICS SHUNT

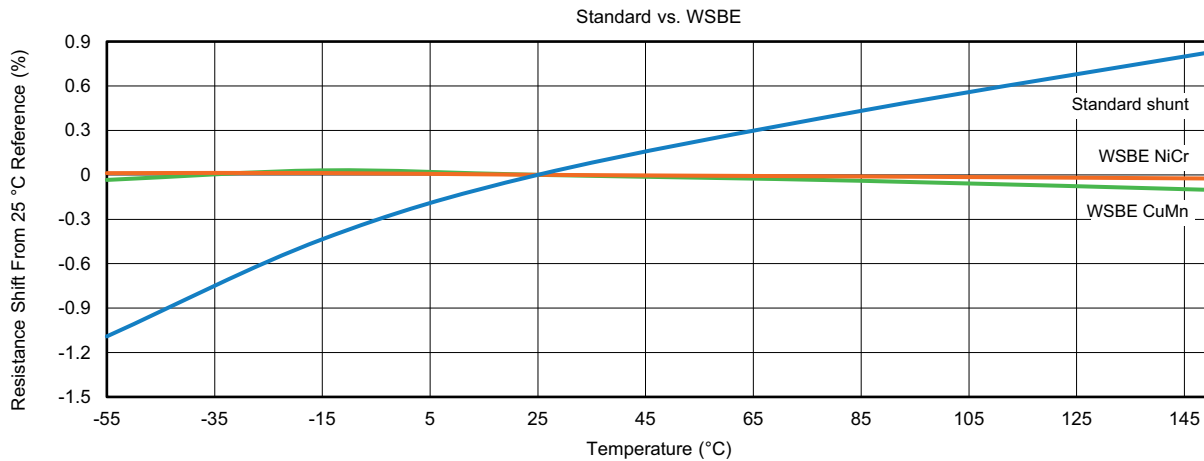

**DIMENSIONS**

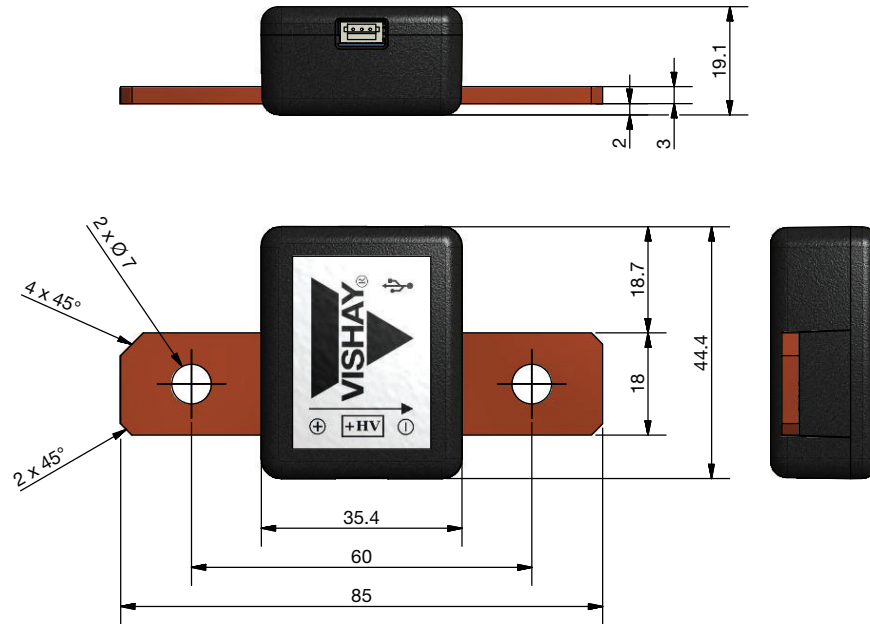

**PACKAGE LIST OF THE REFERENCE KIT**

1. HV-IBSS-USB reference design
2. USB-C to USB-A cable 0.6 m
3. HV-voltage Molex connector with open wires

**ADDITIONAL RESOURCES**

- Calculator: Change of Resistance Due to TCR Calculator [www.vishay.com/resistors/change-resistance-due-to-rtc-calculator/](http://www.vishay.com/resistors/change-resistance-due-to-rtc-calculator/)
- Video: Power Metal Strip® Temperature Coefficient of Resistance [www.vishay.com/videos/resistors/vishays-power-metal-strip-temperature-coefficient-of-resistance.html](http://www.vishay.com/videos/resistors/vishays-power-metal-strip-temperature-coefficient-of-resistance.html)
- Overview: Power Metal Strip® Surface-Mount Current Sensing Resistors [www.vishay.com/doc?49581](http://www.vishay.com/doc?49581)



## Disclaimer

1. Vishay Intertechnology, Inc. and its affiliates (“**Vishay**”) provides the reference design to which this disclaimer is attached (the “**reference design**”), and may provide certain products, parts and components to implement the reference design (each, an “**evaluation kit**”), solely to assist customers and potential customers (each, a “**user**”) who, in a research and development setting, are developing products and applications that incorporate Vishay products. This disclaimer supplements the terms of and conditions under which the user gains access to the reference design and / or evaluation kit (the “**terms and conditions**”). If and to the extent this disclaimer conflicts with the terms and conditions, this disclaimer will control.
2. Vishay and their respective directors, officers, agents, and employees (collectively, the “**Vishay parties**”), disclaim any and all warranties concerning the reference design or evaluation kits, and all liability for any errors, inaccuracies, incompleteness or other defects in the reference design or evaluation kits. Without limiting the foregoing:
  - 2.1. Users are responsible for (a) using their independent analysis, evaluation and judgment to validate the operating parameters, including typical parameters, for each component specified by the reference design or included in an evaluation kit, (b) assuring the safety of the products they develop and the compliance of those products with all applicable regulations, laws and other applicable requirements, and (c) obtaining any licenses to third party intellectual property rights that may be necessary for their products.
  - 2.2. Vishay makes no warranty, representation, or guarantee regarding the suitability of the reference design or evaluation kits for any particular purpose. To the maximum extent permitted by applicable law, Vishay disclaims (i) any and all liability arising out of the application or use of any design or product, (ii) any and all liability, including without limitation special, consequential, or incidental damages, and (iii) any and all implied warranties, including warranties of fitness for particular purpose, non-infringement, and merchantability. The aggregate liability of all Vishay parties will not exceed the amount the Vishay parties received in exchange for the reference design or evaluation kit giving rise to the claim.
  - 2.3. Users acknowledge that (i) the reference design was created under laboratory conditions, and no Vishay party has conducted any testing other than as may be specifically described in the reference design, (ii) any information in the reference design related to third party components described by a reference design or included in an evaluation kit (“**third party products**”) does not constitute a license to use any third party product, or a warranty or endorsement of any third party product, and use of any such information, products or services may require a license from a third party under patents or other intellectual property rights and (iii) Vishay may make corrections, enhancements, improvements and other changes to their respective products and services, reference design, or evaluation kit, and to discontinue any product or service. Vishay has no obligations and makes no claims, representations, warranties, or guarantees regarding third party products included in a reference design or evaluation kit.
  - 2.4. Statements regarding the suitability of the reference design, evaluation kit, or other Vishay product for certain types of applications are based on Vishay’s knowledge of typical requirements often placed on Vishay products in generic applications. Such statements are not binding statements about the suitability of the reference design, evaluation kit, or other Vishay product for a particular application. It is the customer’s responsibility to validate that a particular reference design, evaluation kit, or other Vishay product with the properties described in the reference design or included in the evaluation kit is suitable for a particular application.
  - 2.5. The reference design is not fault-tolerant and is not intended for high risk applications, including without limitation in the operation of nuclear facilities, aircraft navigation or control systems, air traffic control, life support machines, weapons systems, or any other application in which the failure of the reference design could lead to death, personal injury, or severe physical or environmental damages. Any use of the reference design in connection with high risk applications or any other applications is fully at the user’s own risk. Neither the evaluation kits nor their components are intended for commercial products or in consumer or household environments.
3. No license, express or implied, by estoppel or otherwise, to any intellectual property rights is granted by this document or by any conduct of Vishay. Product names and markings noted herein may be trademarks of their respective owners.
4. This disclaimer will be governed by the laws of the Commonwealth of Pennsylvania without reference to conflict of laws principles. User and the Vishay parties agree that the sole and exclusive jurisdiction for any dispute regarding the reference design or evaluation kits will be the state and federal courts sitting in Philadelphia, Pennsylvania.



## Disclaimer

ALL PRODUCT, PRODUCT SPECIFICATIONS AND DATA ARE SUBJECT TO CHANGE WITHOUT NOTICE TO IMPROVE RELIABILITY, FUNCTION OR DESIGN OR OTHERWISE.

Vishay Intertechnology, Inc., its affiliates, agents, and employees, and all persons acting on its or their behalf (collectively, "Vishay"), disclaim any and all liability for any errors, inaccuracies or incompleteness contained in any datasheet or in any other disclosure relating to any product.

Vishay makes no warranty, representation or guarantee regarding the suitability of the products for any particular purpose or the continuing production of any product. To the maximum extent permitted by applicable law, Vishay disclaims (i) any and all liability arising out of the application or use of any product, (ii) any and all liability, including without limitation special, consequential or incidental damages, and (iii) any and all implied warranties, including warranties of fitness for particular purpose, non-infringement and merchantability.

Statements regarding the suitability of products for certain types of applications are based on Vishay's knowledge of typical requirements that are often placed on Vishay products in generic applications. Such statements are not binding statements about the suitability of products for a particular application. It is the customer's responsibility to validate that a particular product with the properties described in the product specification is suitable for use in a particular application. Parameters provided in datasheets and / or specifications may vary in different applications and performance may vary over time. All operating parameters, including typical parameters, must be validated for each customer application by the customer's technical experts. Product specifications do not expand or otherwise modify Vishay's terms and conditions of purchase, including but not limited to the warranty expressed therein.

Hyperlinks included in this datasheet may direct users to third-party websites. These links are provided as a convenience and for informational purposes only. Inclusion of these hyperlinks does not constitute an endorsement or an approval by Vishay of any of the products, services or opinions of the corporation, organization or individual associated with the third-party website. Vishay disclaims any and all liability and bears no responsibility for the accuracy, legality or content of the third-party website or for that of subsequent links.

Except as expressly indicated in writing, Vishay products are not designed for use in medical, life-saving, or life-sustaining applications or for any other application in which the failure of the Vishay product could result in personal injury or death. Customers using or selling Vishay products not expressly indicated for use in such applications do so at their own risk. Please contact authorized Vishay personnel to obtain written terms and conditions regarding products designed for such applications.

No license, express or implied, by estoppel or otherwise, to any intellectual property rights is granted by this document or by any conduct of Vishay. Product names and markings noted herein may be trademarks of their respective owners.