

Aluminum Electrolytic Capacitors Power Long Life 4-Terminal Snap-In

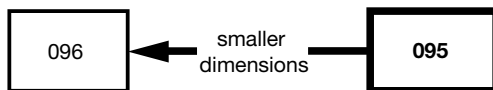

Fig. 1

QUICK REFERENCE DATA	
DESCRIPTION	VALUE
Nominal case size (D x L in mm)	35 x 50 to 45 x 100
Rated capacitance range C_R	390 μ F to 2200 μ F
Tolerance on C_R	$\pm 20\%$
Rated voltage range, U_R	350 V to 450 V
Category temperature range	-40 °C to +85 °C
Endurance test at 85 °C	3000 h
Useful life at 85 °C	10 000 h
Useful life at 40 °C, 1.4 x I_R applied	400 000 h
Shelf life at 0 V, 85 °C	1000 h
Max. RMS value of ripple voltage	12 V
Based on sectional specification	IEC 60384-4 / EN130300
Climatic category IEC 60068	40 / 085 / 56

FEATURES

- Very long useful life: 10 000 h at 85 °C
- Polarized aluminum electrolytic capacitors, non-solid electrolyte
- Large types, minimized dimensions, cylindrical aluminum case, insulated with a blue sleeve
- Pressure relief on the side of the aluminum case
- Temperature range up to 85 °C
- Keyed polarity
- Low ESR, high ripple current capability
- High reliability
- Material categorization: for definitions of compliance please see www.vishay.com/doc?99912

**RoHS
COMPLIANT**

APPLICATIONS

- Telecommunication and industrial systems
- Smoothing and filtering applications
- Switched mode power supplies
- Renewable energy power converters
- Energy storage in pulse systems
- For excellent mounting stability

MARKING

The capacitors are marked (where possible) with the following information:

- Rated capacitance (in μ F)
- Tolerance code on rated capacitance, code letter in accordance with IEC 60062 (M for $\pm 20\%$)
- Rated voltage (in V)
- Date code (YYMM)
- Name of manufacturer
- Code for factory of origin
- “-” sign to identify the negative terminal, visible from the top and side of the capacitor
- Code number
- Climatic category in accordance with IEC 60068

SELECTION CHART FOR C_R , U_R , AND RELEVANT NOMINAL CASE SIZES (\varnothing D x L in mm)				
C_R (μ F)	U_R (V)			
	350	400	420	450
390	-	-	-	35 x 50 40 x 40
470	-	35 x 50 40 x 40	35 x 50 40 x 40	35 x 60 40 x 50 45 x 40
560	35 x 50	35 x 60 45 x 40	35 x 60	35 x 70 40 x 60
680	35 x 60 40 x 50	35 x 70 40 x 60 45 x 50	35 x 70 40 x 60 45 x 50	35 x 80 40 x 60 45 x 50
820	35 x 70 40 x 60	35 x 80 40 x 60	35 x 80 40 x 70 45 x 50	40 x 70 45 x 60
1000	35 x 80 40 x 60 45 x 50	35 x 100 40 x 70 45 x 60	35 x 100 40 x 80 45 x 60	40 x 100 45 x 70
1500	40 x 80 45 x 70	40 x 100 45 x 80	40 x 100 45 x 80	45 x 100
1800	40 x 100	45 x 100	45 x 100	-
2200	45 x 100	-	-	-

DIMENSIONS in millimeters **AND AVAILABLE FORMS**

PRINTED WIRING

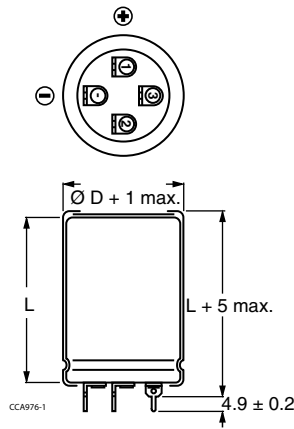

Fig. 2 - Printed wiring pin version
(Case Ø D = 35 mm)

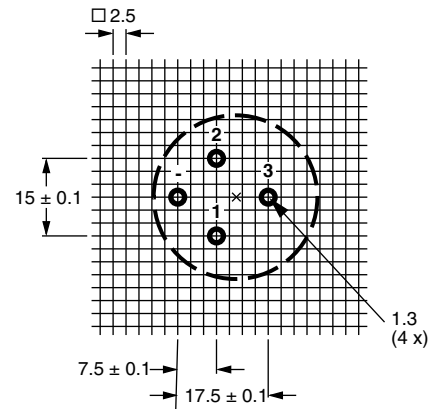

Fig. 3 - Mounting hole diagram viewed from component side
(Case Ø D = 35 mm)

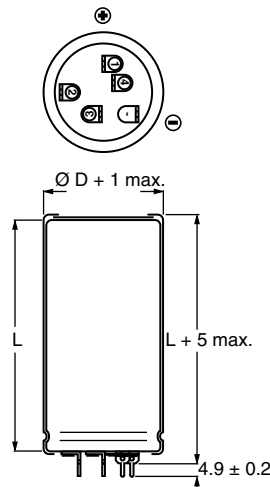

Fig. 4 - Printed wiring pin version
(Case Ø D = 40 mm)

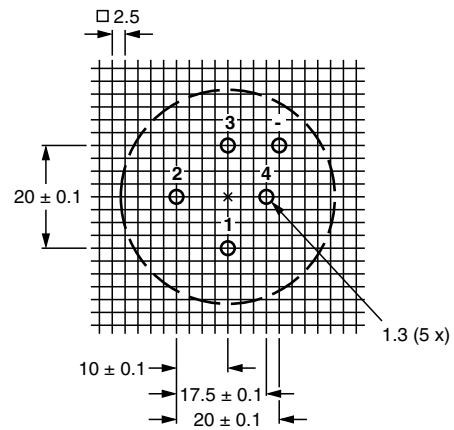
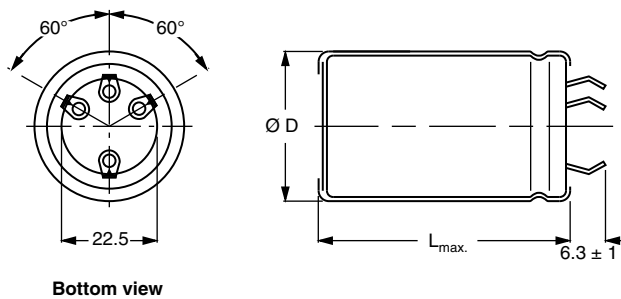

Fig. 5 - Mounting hole diagram viewed from component side
(Case Ø D = 40 mm)

FOUR TERMINAL SNAP-IN



Bottom view

Fig. 6 - 4-Terminal snap-in

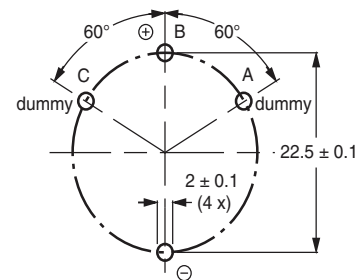

Dummy terminals (A and C) must be free from the electrical circuit

Fig. 7 - Mounting hole diagram

Pin number 1 is the positive terminal. Pin “-” is the negative terminal.

Pin numbers 2, 3 and 4 (if present) should be free from the electrical circuit or connected to the minus terminal.



Table 1

DIMENSIONS in millimeters, MASS AND PACKAGING QUANTITIES						
NOMINAL CASE SIZE Ø D x L	Ø D _{max.}	4T-SI L _{max.}	PW L + 5	MASS (g)	PACKAGING QUANTITIES (units per box)	CARDBOARD BOX DIMENSIONS L x W x H
35 x 50	36	52	55	72	50	390 x 198 x 60
35 x 60	36	62	65	91	50	390 x 198 x 70
35 x 70	36	72	75	103	50	377 x 375 x 97
35 x 80	36	82	85	115	50	377 x 375 x 107
35 x 100	36	102	105	151	50	377 x 375 x 127
40 x 40	41	42	45	70	50	440 x 223 x 60
40 x 50	41	52	55	94	50	440 x 223 x 70
40 x 60	41	62	65	118	25	230 x 230 x 80
40 x 70	41	72	75	134	25	230 x 230 x 90
40 x 80	41	82	85	150	25	230 x 230 x 100
40 x 100	41	102	105	176	25	230 x 230 x 120
45 x 40	46	42	-	88	36	TBD
45 x 50	46	52	-	119	36	377 x 375 x 77
45 x 60	46	62	-	150	36	377 x 375 x 87
45 x 70	46	72	-	170	36	377 x 375 x 97
45 x 80	46	82	-	190	36	377 x 375 x 107
45 x 100	46	102	-	250	36	377 x 375 x 127

ELECTRICAL DATA	
SYMBOL	DESCRIPTION
C _R	Rated capacitance at 100 Hz
I _R	Rated RMS ripple current at 100 Hz and 85 °C
I _{L5}	Max. leakage current after 5 min at U _R
ESR	Max. equivalent series resistance at 100 Hz
Z	Max. impedance at 10 kHz

Note

- Unless otherwise specified, all electrical values in Table 2 apply at T_{amb} = 20 °C, P = 86 kPa to 106 kPa, RH = 45 % to 75 %

ORDERING EXAMPLE

Electrolytic capacitor 095 series

1000 µF / 450 V;

Nominal case size: Ø 40 mm x 100 mm

4-terminal snap-in:

Ordering code: MAL2 095 27102 E3

Former 12NC: 2222 095 27102

Printed wiring:

Ordering code: MAL2 095 77102 E3

Former 12NC: 2222 095 77102

Table 2

ELECTRICAL DATA AND ORDERING INFORMATION								
U _R (V)	C _R 100 Hz (µF)	NOMINAL CASE SIZE Ø D x L (mm)	I _R 100 Hz 85 °C (A)	I _{L5} 5 min (µA)	ESR _{max.} 100 Hz (mΩ)	Z _{max.} 10 kHz (mΩ)	ORDERING CODE MAL2095.....	
							4T-SI	PW
350	560	35 x 50	3.4	396	196	120	15561E3	65561E3
	680	35 x 60	4.0	480	162	99	15681E3	65681E3
	680	40 x 50	4.1	480	165	102	25681E3	75681E3
	820	35 x 70	4.5	578	135	82	15821E3	65821E3
	820	40 x 60	4.6	578	137	85	25821E3	75821E3
	1000	35 x 80	5.1	704	112	68	15102E3	65102E3
	1000	40 x 60	5.0	704	116	73	25102E3	75102E3
	1000	45 x 50	5.0	704	121	78	35102E3	-
	1500	40 x 80	6.5	1054	79	50	25152E3	75152E3
	1500	45 x 70	6.5	1054	82	53	35152E3	-
	1800	40 x 100	7.5	1264	66	42	25182E3	75182E3
	2200	45 x 100	8.6	1544	57	37	35222E3	-



ELECTRICAL DATA AND ORDERING INFORMATION								
U _R (V)	C _R 100 Hz (µF)	NOMINAL CASE SIZE Ø D x L (mm)	I _R 100 Hz 85 °C (A)	I _{L5} 5 min (µA)	ESR _{max.} 100 Hz (mΩ)	Z _{max.} 10 kHz (mΩ)	ORDERING CODE MAL2095.....	
							4T-SI	PW
400	470	35 x 50	3.2	380	215	126	16471E3	66471E3
	470	40 x 40	3.0	380	222	132	26471E3	76471E3
	560	35 x 60	3.7	452	180	105	16561E3	66561E3
	560	45 x 40	3.2	452	192	116	36561E3	-
	680	35 x 70	4.1	548	149	87	16681E3	66681E3
	680	40 x 60	4.3	548	151	89	26681E3	76681E3
	680	45 x 50	4.3	548	156	93	36681E3	-
	820	35 x 80	4.7	660	125	73	16821E3	66821E3
	820	40 x 60	4.6	660	129	77	26821E3	76821E3
	1000	35 x 100	5.9	804	102	60	16102E3	66102E3
	1000	40 x 70	5.2	804	107	64	26102E3	76102E3
	1000	45 x 60	5.4	804	110	67	36102E3	-
	1500	40 x 100	7.2	1204	72	43	26152E3	76152E3
	1500	45 x 80	6.7	1204	75	47	36152E3	-
	1800	45 x 100	7.9	1444	63	38	36182E3	-
	420	470	35 x 50	3.1	399	232	141	14471E3
470		40 x 40	3.0	399	238	147	24471E3	74471E3
560		35 x 60	3.6	474	194	119	14561E3	64561E3
680		35 x 70	4.1	575	161	98	14681E3	64681E3
680		40 x 60	4.3	575	163	100	24681E3	74681E3
680		45 x 50	4.3	575	167	104	34681E3	-
820		35 x 80	4.6	693	134	82	14821E3	64821E3
820		40 x 70	4.8	693	136	84	24821E3	74821E3
820		45 x 50	4.6	693	143	91	34821E3	-
1000		35 x 100	5.8	844	110	67	14102E3	64102E3
1000		40 x 80	5.4	844	112	69	24102E3	74102E3
1000		45 x 60	5.4	844	117	75	34102E3	-
1500		40 x 100	7.2	1264	77	48	24152E3	74152E3
1500		45 x 80	6.7	1264	80	51	34152E3	-
1800		45 x 100	7.8	1516	67	43	34182E3	-
450		390	35 x 50	2.9	355	246	142	17391E3
	390	40 x 40	2.8	355	253	148	27391E3	77391E3
	470	35 x 60	3.4	427	204	118	17471E3	67471E3
	470	40 x 50	3.5	427	208	121	27471E3	77471E3
	470	45 x 40	3.0	427	217	129	37471E3	-
	560	35 x 70	3.8	508	172	99	17561E3	67561E3
	560	40 x 60	4.0	508	174	101	27561E3	77561E3
	680	35 x 80	4.3	616	143	82	17681E3	67681E3
	680	40 x 60	4.3	616	147	87	27681E3	77681E3
	680	45 x 50	4.3	616	153	91	37681E3	-
	820	40 x 70	4.8	742	123	72	27821E3	77821E3
	820	45 x 60	5.0	742	126	76	37821E3	-
	1000	40 x 100	6.0	904	99	57	27102E3	77102E3
	1000	45 x 70	5.6	904	104	63	37102E3	-
	1200	40 x 100	6.4	1084	85	50	27122E3	77122E3
	1500	45 x 100	7.4	1354	71	42	37152E3	-



ADDITIONAL ELECTRICAL DATA		
PARAMETER	CONDITIONS	VALUE
Voltage		
Surge voltage	≥ 350 V versions	$U_s = 1.1 \times U_R$
Reverse voltage		$U_{rev} \leq 1$
Current		
Leakage current	After 1 min at U_R	$I_{L1} \leq 0.006 C_R \times U_R + 4 \mu A$
	After 5 min at U_R	$I_{L5} \leq 0.002 C_R \times U_R + 4 \mu A$
Inductance		
Equivalent series inductance (ESL)	All case sizes	Ca. 20 nH

RIPPLE CURRENT AND USEFUL LIFE

Table 3

ENDURANCE TEST DURATION AND USEFUL LIFE	
ENDURANCE AT 85 °C (h)	USEFUL LIFE AT 85 °C (h)
3000	10 000

Note

- Multiplier of useful life code: CCC205-05

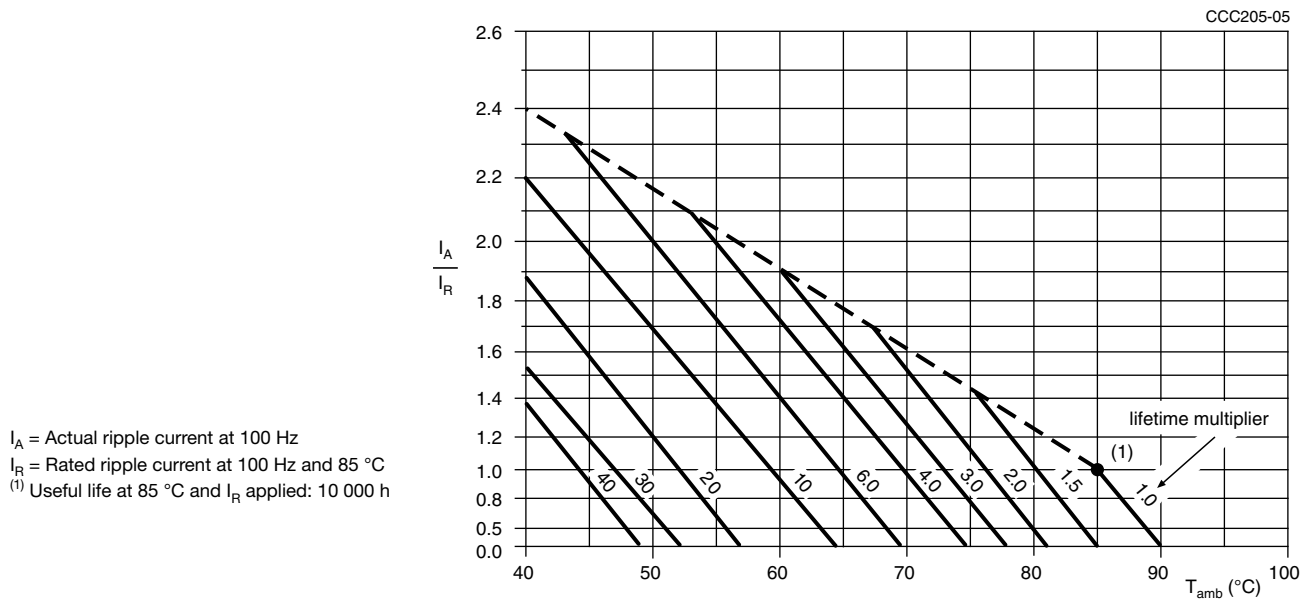

Fig. 8 - Multiplier of useful life as a function of ambient temperature and ripple current load

Table 4

MULTIPLIER OF RIPPLE CURRENT (I_R) AS A FUNCTION OF FREQUENCY					
FREQUENCY (Hz)					
50	100	200	400	1000	10 000
I_R MULTIPLIER					
0.9	1.0	1.2	1.3	1.4	1.5



Table 5

TEST PROCEDURES AND REQUIREMENTS			
TEST		PROCEDURE	REQUIREMENTS
NAME OF TEST	REFERENCE		
Endurance	IEC 60384-4 / EN130300 subclause 4.13	T _{amb} = 85 °C; U _R applied; 3000 h	ΔC/C: ± 10 % ESR ≤ 1.3 x spec. limit Z ≤ 2 x spec. limit I _{L5} ≤ spec. limit
Useful life	CECC 30301 subclause 4.13	T _{amb} = 85 °C; U _R and I _R applied; 10 000 h	ΔC/C: ± 30 % ESR ≤ 3 x spec. limit Z ≤ 3 x spec. limit I _{L5} ≤ spec. limit no short or open circuit, no visible damage total failure percentage ≤ 3 %
Shelf life	IEC 60384-4 / EN130300 subclause 4.17	T _{amb} = 85 °C; no voltage applied; 1000 h After test: U _R to be applied for 30 min 24 h to 48 h before measurement	ΔC/C: ± 10 % ESR ≤ 1.2 x spec. limit I _{L5} ≤ 2 x spec. limit

Statements about product lifetime are based on calculations and internal testing. They should only be interpreted as estimations. Also due to external factors, the lifetime in the field application may deviate from the calculated lifetime. In general, nothing stated herein shall be construed as a guarantee of durability.



Disclaimer

ALL PRODUCT, PRODUCT SPECIFICATIONS AND DATA ARE SUBJECT TO CHANGE WITHOUT NOTICE TO IMPROVE RELIABILITY, FUNCTION OR DESIGN OR OTHERWISE.

Vishay Intertechnology, Inc., its affiliates, agents, and employees, and all persons acting on its or their behalf (collectively, "Vishay"), disclaim any and all liability for any errors, inaccuracies or incompleteness contained in any datasheet or in any other disclosure relating to any product.

Vishay makes no warranty, representation or guarantee regarding the suitability of the products for any particular purpose or the continuing production of any product. To the maximum extent permitted by applicable law, Vishay disclaims (i) any and all liability arising out of the application or use of any product, (ii) any and all liability, including without limitation special, consequential or incidental damages, and (iii) any and all implied warranties, including warranties of fitness for particular purpose, non-infringement and merchantability.

Statements regarding the suitability of products for certain types of applications are based on Vishay's knowledge of typical requirements that are often placed on Vishay products in generic applications. Such statements are not binding statements about the suitability of products for a particular application. It is the customer's responsibility to validate that a particular product with the properties described in the product specification is suitable for use in a particular application. Parameters provided in datasheets and / or specifications may vary in different applications and performance may vary over time. All operating parameters, including typical parameters, must be validated for each customer application by the customer's technical experts. Product specifications do not expand or otherwise modify Vishay's terms and conditions of purchase, including but not limited to the warranty expressed therein.

Except as expressly indicated in writing, Vishay products are not designed for use in medical, life-saving, or life-sustaining applications or for any other application in which the failure of the Vishay product could result in personal injury or death. Customers using or selling Vishay products not expressly indicated for use in such applications do so at their own risk. Please contact authorized Vishay personnel to obtain written terms and conditions regarding products designed for such applications.

No license, express or implied, by estoppel or otherwise, to any intellectual property rights is granted by this document or by any conduct of Vishay. Product names and markings noted herein may be trademarks of their respective owners.