

## Ø 10 mm Film Dielectric Trimmers



### FEATURES

- Housing diameter 10 mm
- For a basic grid of 2.54 mm (0.1") or 2.50 mm
- Top and bottom or top adjustment
- Round head
- Mounting: radial
- Material categorization: for definitions of compliance please see [www.vishay.com/doc?99912](http://www.vishay.com/doc?99912)



**RoHS**  
COMPLIANT

### APPLICATIONS

- Antennas
- Impedance matching circuits
- Medical
- RF
- For consumer and industrial equipment

| QUICK REFERENCE DATA                                       |   |                  |
|--|---|------------------|
| Rated DC voltage   | 150 V <sub>DC</sub>   |                  |
| Test DC voltage for 1 min                                  | 300 V <sub>DC</sub>   |                  |
| Maximum contact resistance                                 | 10 mΩ   |                  |
| Minimum insulation resistance                              | 10 000 MΩ   |                  |
| Category temperature range                                 | PP  | -40 °C to +70 °C |
|  | PTFE  | -40 °C to +85 °C |
| Climatic category (IEC 60068)                              | PP  | 40/070/21        |
|  | PTFE  | 40/085/21        |
| Minimum storage temperature                                | -55 °C  |                  |
| Related specification                                      | IEC 60418-1 and 4   |                  |
| Effective angle of rotation                                | 180° (rotation in 180° only, see "Life of trimmer")   |                  |
| Operating torque   | 2 mNm to 25 mNm   |                  |
| Maximum axial thrust                                       | 2 N   |                  |
| Capacitance range (C <sub>min.</sub> / C <sub>max.</sub> ) | 2.5 pF / 15 pF to 5.5 pF / 65 pF  |                  |
| Life of trimmer  | Maximum 10 cycles: rotation in 180° only (the electrical and mechanical performance is not guaranteed if rotated beyond 10 cycles)  |                  |
| Quality level  | Sampling and data evaluation for quality level in accordance with "MIL-STD-105D" and "IEC 60410":<br>< 0.15 % major defects<br>< 0.65 % minor defects<br><br>Each capacitor is tested for minimum C <sub>max.</sub> and is also subjected to the full test voltage. |                  |

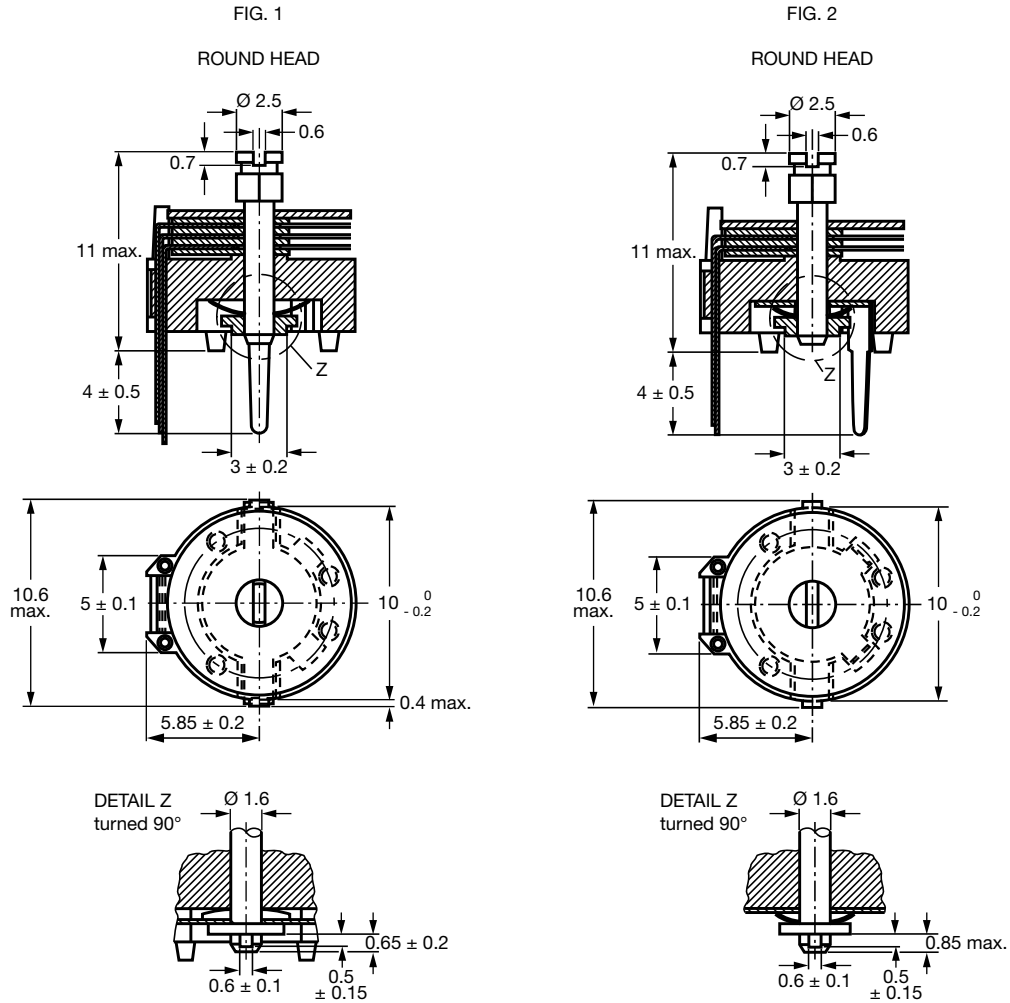
**DIMENSIONS** in millimeters



Trimmers BFC2 808 ..... series

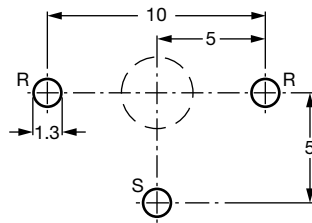

R = Rotor, S = Stator

The large hole is for bottom adjustment and the diameter is determined by user's requirements.

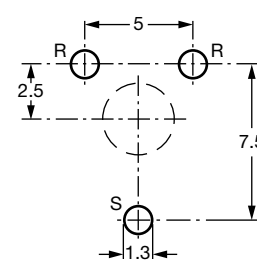

R = Rotor, S = Stator

Hole pattern

**ADJUSTMENT**

For top adjustment a screwdriver or trimming key can be used; for bottom adjustment a key is required as shown below.

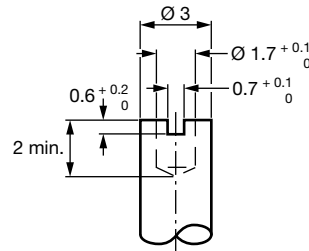

Bottom adjustment key

| ORDERING INFORMATION                          |                               |                               |                |
|---|-------------------------------|-------------------------------|----------------|
| C <sub>min.</sub> / C <sub>max.</sub><br>(pF) | CATALOG NUMBER BFC2 808 ..... |                               |                |
|   | HOLE PATTERN<br>5 mm x 10 mm  | HOLE PATTERN<br>7.5 mm x 5 mm |                |
|   | ROUND HEAD                    | ROUND HEAD                    | ROUND HEAD     |
|   | TOP AND BOTTOM ADJUSTMENT     |                               | TOP ADJUSTMENT |
| 2.5 / 15                                      | 31159                         | 32159                         | -              |
| 3 / 22.5                                      | 31229                         | 32229                         | -              |
| 5.5 / 40                                      | 31409                         | 32409                         | -              |
| 5.5 / 50                                      | 01029                         | 01006                         | -              |
| 5.5 / 65                                      | 31659                         | 32659                         | 01001          |

**MOUNTING**

The trimmer can be mounted on printed-circuit boards with a grid of 2.50 mm or 2.54 mm and a minimum hole diameter of 1.25 mm.

**PACKAGING**

Bulk packaged in cardboard boxes lined with expanded plastic. For smallest packaging quantities (SPQ) see “Electrical Data” table.

| ELECTRICAL DATA  |                     |      |              |       |  |         |  |  |                    |         |                                  |
|--|---------------------|------|--------------|-------|--|---------|--|--|--------------------|---------|----------------------------------|
| GUARANTEED<br>MAX. C <sub>min.</sub> /<br>MIN. C <sub>max.</sub><br>AT 200 kHz<br>(pF) | SHAPE<br>OF<br>HEAD | FIG. | ADJ. MODE    | DIEL. | tan δ<br>AT C <sub>max.</sub> x 10 <sup>-4</sup> |         | TEMP.<br>COEFF.<br>(10 <sup>-6</sup> /K) | MIN. f <sub>res</sub><br>AT C <sub>max.</sub><br>(MHz) | COL.<br>OF<br>BASE | SP<br>Q | CATALOG<br>NUMBER<br>BFC2 ... .. |
|  |                     |      |              |       | 1 MHz  | 100 MHz |  |  |                    |         |                                  |
| 2.5 / 15   | Round               | 1    | Top + bottom | PP    | ≤ 10   | ≤ 25    | -200 ± 700                               | 420  | Blue               | 800     | .... 808 31159                   |
|  |                     | 2    |              |       |  |         |  |  |                    | 800     | .... 808 32159                   |
| 3 / 22.5   | Round               | 1    | Top + bottom | PP    | ≤ 10   | ≤ 25    | -200 ± 700                               | 200  | Green              | 800     | .... 808 31229                   |
|  |                     | 2    |              |       |  |         |  |  |                    | 800     | .... 808 32229                   |
| 5.5 / 40   | Round               | 1    | Top + bottom | PP    | ≤ 10   | ≤ 25    | -200 ± 400                               | 200  | Grey               | 800     | .... 808 31409                   |
|  |                     | 2    |              |       |  |         |  |  |                    | 800     | .... 808 32409                   |
| 5.5 / 50   | Round               | 1    | Top + bottom | PTFE  | ≤ 10   | ≤ 25    | -200 ± 400                               | 170  | Yellow             | 800     | .... 808 01029                   |
|  |                     | 2    |              |       |  |         |  |  |                    | 800     | .... 808 01006                   |
| 5.5 / 65   | Round               | 2    | Top          | PP    | ≤ 10   | ≤ 25    | -200 ± 500                               | 170  | Yellow             | 800     | .... 808 01001                   |
|  | Round               | 1    | Top + bottom |       |  |         |  |  |                    | 800     | .... 808 31659                   |
|  | Round               | 2    |              |       |  |         |  |  |                    | 800     | .... 808 32659                   |

**SOLDERING CONDITIONS**

For general soldering conditions and wave soldering profile, we refer to the application note “Soldering Guidelines for Film Capacitors”: [www.vishay.com/doc?28171](http://www.vishay.com/doc?28171)



| TEST PROCEDURES AND REQUIREMENTS |                       |   |   |  |
|----------------------------------|-----------------------|---|---|--|
| IEC 60418-1 CLAUSE               | IEC 60068 TEST METHOD | TEST                                    | PROCEDURE   | REQUIREMENTS   |
| 4.2                              |                       | Method of mounting                      | Method A  |  |
| 14                               |                       | Capacitance drift                       | After TC measurement  | $\Delta C/C: \leq 4.5\%$ for $C_{max.} < 40\text{ pF}$ ;<br>$\Delta C/C: \leq 2.5\%$ for $C_{max.} \geq 40\text{ pF}$  |
| 19                               |                       | Thrust                                  | Axial thrust of 2 N   | $\Delta C/C: \leq 0.3\%$   |
| 21                               |                       | Robustness of terminations:             |   |  |
| 21.1                             | Ua                    | Tensile                                 | 1 N   | No damage  |
| 21.2                             | Ub                    | Bending                                 | 1 cycle   | No damage  |
| 22                               | Na                    | Rapid change of temperature             | 1 cycle; 0.5 h at lower and 0.5 h at upper category temperature   | $\Delta C/C: \leq 1.5\%$   |
| 23                               | T                     | Soldering:                              |   |  |
|                                  | Ta                    | Solderability                           | Solder bath immersion 3 mm; 235 °C; 2 s   | Good wetting, no mechanical damage   |
|                                  | Tb                    | Resistance to heat                      | Solder bath: 260 °C; 10 s   | No mechanical damage   |
| 24                               | Eb                    | Impact bump                             | 4000 ± 10 bumps; 40 g; 6 ms   | $\Delta C/C: \leq 0.4\%$ ;<br>no mechanical damage   |
| 25                               | Fc                    | Vibration                               | Frequency 10 Hz to 55 Hz; amplitude 0.35 mm; 1.5 h  | $\Delta C/C: \leq 0.8\%$ ;<br>no mechanical damage   |
| 26                               |                       | Climatic sequence:                      |   | $\Delta C/C: \leq 3\%$ for $C_{max.} < 80\text{ pF}$ ;<br>$\Delta C/C: \leq 6\%$ for $C_{max.} \geq 80\text{ pF}$  |
| 26.1                             | B                     | Dry heat                                | 16 h at upper category temperature  | $\tan \delta: \leq 15 \times 10^{-4}$ for $C_{max.} < 80\text{ pF}$ ;<br>$\tan \delta: \leq 80 \times 10^{-4}$ for $C_{max.} \geq 80\text{ pF}$<br><br>$R_{ins.}: \geq 10\,000\text{ M}\Omega$ ;<br>rotor contact R: $\leq 10\ \Omega$   |
| 26.2                             | D                     | Damp heat accelerated, first cycle      | 1 cycle; 24 h; +40 °C; 95 % to 100 % RH   | Voltage proof:<br>300 V for 1 min  |
| 26.3                             | Aa                    | Cold                                    | 16 h; -40 °C  | Visual examination:<br>no mechanical damage  |
| 26.5                             |                       | Damp heat accelerated, remaining cycles | 1 cycle; 24 h; +40 °C; 95 % to 100 % RH   | Operating torque: 2 mNm to 35 mNm  |
| 27                               | Ca                    | Damp heat steady state                  | 21 days; +40 °C; 90 % to 95 % RH  | $\Delta C/C:$<br>$\leq 3\%$ for $C_{max.} < 100\text{ pF}$ ;<br>$\leq 3\%$ for $C_{max.} \geq 100\text{ pF}$<br><br>$\tan \delta: \leq 20 \times 10^{-4}$ for $C_{max.} < 80\text{ pF}$ ;<br>$\tan \delta: \leq 80 \times 10^{-4}$ for $C_{max.} \geq 80\text{ pF}$<br><br>$R_{ins.}: \geq 10\,000\text{ M}\Omega$ ;<br>rotor contact R: $\leq 10\text{ m}\Omega$<br><br>Voltage proof:<br>300 V for 1 min<br><br>Visual examination:<br>no mechanical damage<br><br>Operating torque: 2 mNm to 35 mNm |
| 29                               |                       | Mechanical endurance                    | 10 cycles<br><br>Maximum 10 cycles: rotation in 180° only (the electrical and mechanical performance is not guaranteed if rotated beyond 10 cycles) | $\Delta C/C: \leq 1\%$<br><br>$\Delta C/C$ after axial thrust: $\leq 0.4\%$ ;<br>rotor contact R: $\leq 10\text{ m}\Omega$<br><br>Voltage proof:<br>300 V for 1 min<br><br>Visual examination:<br>no mechanical damage<br><br>Operating torque: 1.5 mNm to 37 mNm  |



## Disclaimer

ALL PRODUCT, PRODUCT SPECIFICATIONS AND DATA ARE SUBJECT TO CHANGE WITHOUT NOTICE TO IMPROVE RELIABILITY, FUNCTION OR DESIGN OR OTHERWISE.

Vishay Intertechnology, Inc., its affiliates, agents, and employees, and all persons acting on its or their behalf (collectively, "Vishay"), disclaim any and all liability for any errors, inaccuracies or incompleteness contained in any datasheet or in any other disclosure relating to any product.

Vishay makes no warranty, representation or guarantee regarding the suitability of the products for any particular purpose or the continuing production of any product. To the maximum extent permitted by applicable law, Vishay disclaims (i) any and all liability arising out of the application or use of any product, (ii) any and all liability, including without limitation special, consequential or incidental damages, and (iii) any and all implied warranties, including warranties of fitness for particular purpose, non-infringement and merchantability.

Statements regarding the suitability of products for certain types of applications are based on Vishay's knowledge of typical requirements that are often placed on Vishay products in generic applications. Such statements are not binding statements about the suitability of products for a particular application. It is the customer's responsibility to validate that a particular product with the properties described in the product specification is suitable for use in a particular application. Parameters provided in datasheets and / or specifications may vary in different applications and performance may vary over time. All operating parameters, including typical parameters, must be validated for each customer application by the customer's technical experts. Product specifications do not expand or otherwise modify Vishay's terms and conditions of purchase, including but not limited to the warranty expressed therein.

Hyperlinks included in this datasheet may direct users to third-party websites. These links are provided as a convenience and for informational purposes only. Inclusion of these hyperlinks does not constitute an endorsement or an approval by Vishay of any of the products, services or opinions of the corporation, organization or individual associated with the third-party website. Vishay disclaims any and all liability and bears no responsibility for the accuracy, legality or content of the third-party website or for that of subsequent links.

Except as expressly indicated in writing, Vishay products are not designed for use in medical, life-saving, or life-sustaining applications or for any other application in which the failure of the Vishay product could result in personal injury or death. Customers using or selling Vishay products not expressly indicated for use in such applications do so at their own risk. Please contact authorized Vishay personnel to obtain written terms and conditions regarding products designed for such applications.

No license, express or implied, by estoppel or otherwise, to any intellectual property rights is granted by this document or by any conduct of Vishay. Product names and markings noted herein may be trademarks of their respective owners.