

Aluminum Electrolytic Capacitors SMD (Chip), High Temperature, Low Impedance

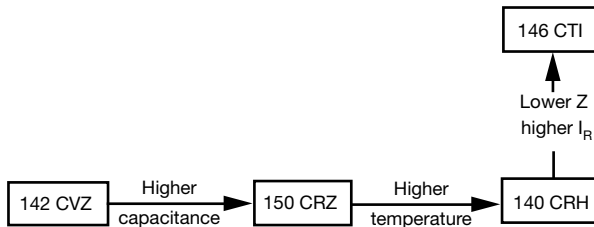

Fig. 1

QUICK REFERENCE DATA	
DESCRIPTION	VALUE
Nominal case sizes (L x W x H in mm)	4 x 4 x 5.7 to 12.5 x 12.5 x 13
Rated capacitance range, C_R	1 μ F to 2200 μ F
Tolerance on C_R	± 20 %
Rated voltage range, U_R	6.3 V to 100 V
Category temperature range	-55 °C to +105 °C
Endurance test at 105 °C	1000 h to 3000 h
Useful life at 105 °C	2000 h to 5000 h
Useful life at 40 °C 1.8 x I_R applied	100 000 h to 250 000 h
Shelf life at 0 V, 105 °C	1000 h
Based on sectional specification	IEC 60384-18 / CECC 32300
Climatic category IEC 60068	55 / 150 / 56

FEATURES

- Useful life: up to 5000 h at 105 °C
- High reliability
- Low ESR
- Polarized aluminum electrolytic capacitors, non-solid electrolyte, self healing
- SMD-version with baseplate, lead (Pb)-free reflow solderable
- Charge and discharge proof
- Material categorization: for definitions of compliance please see www.vishay.com/doc?99912

**RoHS
COMPLIANT**

APPLICATIONS

- SMD technology for high density assemblies
- Large capacitance with ultra low impedance
- Industrial and professional application
- Smoothing, filtering and buffering
- General industrial, telecom

MARKING

- Rated capacitance (in μ F)
- Rated voltage (in V)
- Date code, in accordance with IEC 60062
- Black mark or “-” sign indicating the cathode (the anode is identified by bevelled edges)

PACKAGING

Supplied in blister tape on reel



SELECTION CHART FOR C _R , U _R , AND RELEVANT NOMINAL CASE SIZES (L x W x H in mm)									
C _R (μF)	U _R (V)								
	6.3	10	16	25	35	50	63	80	100
1						4 x 4 x 5.7			
2.2						4 x 4 x 5.7			
3.3						4 x 4 x 5.7			
4.7					4 x 4 x 5.7	5 x 5 x 5.7	5 x 5 x 5.7		
10			4 x 4 x 5.7	4 x 4 x 5.7	5 x 5 x 5.7	6.3 x 6.3 x 5.7	6.3 x 6.3 x 5.7		
22	4 x 4 x 5.7	4 x 4 x 5.7	5 x 5 x 5.7	5 x 5 x 5.7	6.3 x 6.3 x 5.7	6.3 x 6.3 x 5.7	6.3 x 6.3 x 7.7		8 x 8 x 10
33	4 x 4 x 5.7	5 x 5 x 5.7	6.3 x 6.3 x 5.7	6.3 x 6.3 x 5.7	6.3 x 6.3 x 5.7	6.3 x 6.3 x 7.7	8 x 8 x 10	8 x 8 x 10	10 x 10 x 10
47	5 x 5 x 5.7	6.3 x 6.3 x 5.7	6.3 x 6.3 x 5.7	6.3 x 6.3 x 5.7	6.3 x 6.3 x 5.7	6.3 x 6.3 x 7.7	8 x 8 x 10		10 x 10 x 10
68				6.3 x 6.3 x 5.7	8 x 8 x 6.5	8 x 8 x 10			
100	6.3 x 6.3 x 5.7	6.3 x 6.3 x 5.7	6.3 x 6.3 x 5.7	6.3 x 6.3 x 7.7	8 x 8 x 10	8 x 8 x 10	10 x 10 x 10	10 x 10 x 10	12.5 x 12.5 x 13
						10 x 10 x 10			
150	6.3 x 6.3 x 5.7	6.3 x 6.3 x 5.7	6.3 x 6.3 x 7.7	8 x 8 x 10	8 x 8 x 10	10 x 10 x 10	12.5 x 12.5 x 13	12.5 x 12.5 x 13	
220		8 x 8 x 6.5	6.3 x 6.3 x 7.7	8 x 8 x 10	8 x 8 x 10	12.5 x 12.5 x 13	12.5 x 12.5 x 13		
					10 x 10 x 10				
330	8 x 8 x 6.5			8 x 8 x 10	10 x 10 x 10	12.5 x 12.5 x 13			
					12.5 x 12.5 x 13				
470			8 x 8 x 10	10 x 10 x 10					
680	8 x 8 x 10		10 x 10 x 10	12.5 x 12.5 x 13					
1000	8 x 8 x 10	10 x 10 x 10	12.5 x 12.5 x 13						
1500	10 x 10 x 10	12.5 x 12.5 x 13							
2200	12.5 x 12.5 x 13								

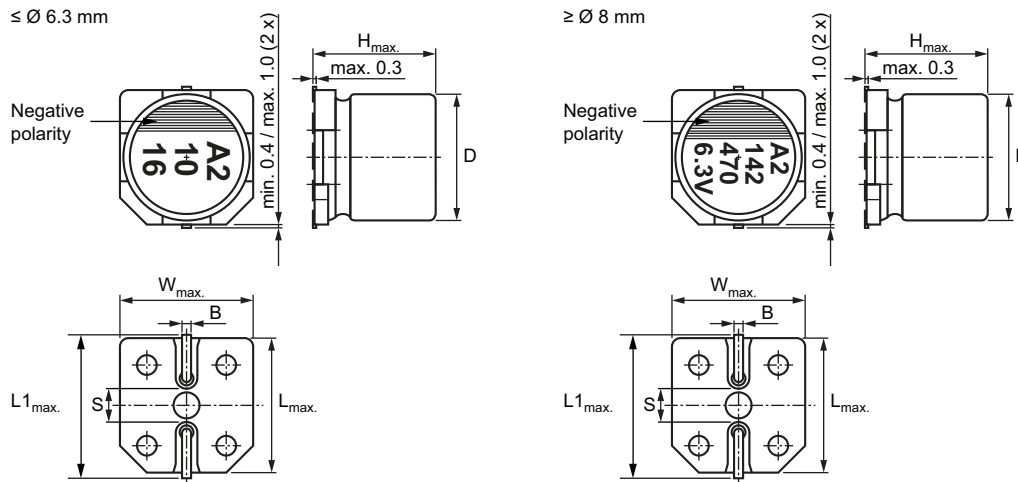

Fig. 2 - Dimensional outline

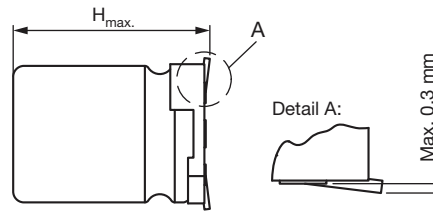

Fig. 3 - Coplanarity of pins

Table 1

DIMENSIONS in millimeters, AND MASS									
NOMINAL CASE SIZE L x W x H	CASE CODE	L _{max.}	W _{max.}	H _{max.}	Ø D	B _{max.}	S	L1 _{max.}	MASS (g)
4 x 4 x 5.7	0406	4.5	4.5	6.0	4	0.8	1.0	5.3	≈ 0.15
5 x 5 x 5.7	0506	5.5	5.5	6.0	5	0.8	1.5	6.1	≈ 0.25
6.3 x 6.3 x 5.7	0606	6.8	6.8	6.0	6.3	0.8	2.0	7.4	≈ 0.30
6.3 x 6.3 x 7.7	0608	6.8	6.8	8.0	6.3	0.8	2.0	7.4	≈ 0.45
8 x 8 x 6.5	0807	8.5	8.5	6.8	8	0.8	2.3	9.2	≈ 0.45
8 x 8 x 10	0810	8.5	8.5	10.5	8	1.1	3.1	9.2	≈ 0.90
10 x 10 x 10	1010	10.5	10.5	10.5	10	1.3	4.7	11.2	≈ 1.40
12.5 x 12.5 x 13	1213	13.2	13.2	14.0	12.5	1.4	4.4	13.9	≈ 2.60

Table 2

TAPE AND REEL DIMENSIONS in millimeters, PACKAGING QUANTITIES						
NOMINAL CASE SIZE L x W x H	CASE CODE	PITCH P ₁	TAPE WIDTH W	TAPE THICKNESS T ₂	REEL DIAMETER	PACKAGING QUANTITIES
4 x 4 x 5.7	0406	8	12	6.2	380	2000
5 x 5 x 5.7	0506	12	12	6.2	380	1000
6.3 x 6.3 x 5.7	0606	12	16	6.2	380	1000
6.3 x 6.3 x 7.7	0608	12	16	8.3	380	1000
8 x 8 x 6.5	0807	12	16	7.4	380	1000
8 x 8 x 10	0810	16	24	11.0	380	500
10 x 10 x 10	1010	16	24	11.0	380	500
12.5 x 12.5 x 13	1213	24	32	14.5	380	200

Note

(1) Detailed tape dimensions see section "PACKAGING"

MOUNTING

The capacitors are designed for automatic placement on to printed-circuit boards.

Optimum dimensions of soldering pads depend amongst others on soldering method, mounting accuracy, print layout and / or adjacent components.

For recommended soldering pad dimensions, refer to Fig. 4 and Table 3.

SOLDERING

Soldering conditions are defined by the curve, temperature versus time, where the temperature is that measured on the component during processing.

For maximum conditions refer to Fig. 5.

Any temperature versus time curve which does not exceed the specified maximum curves may be applied.

As a general principle, temperature and duration shall be the minimum necessary required to ensure good soldering connections. However, the specified maximum curves should never be exceeded.

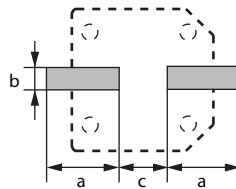

Fig. 4 - Recommended soldering pad dimensions

Table 3

RECOMMENDED SOLDERING PAD DIMENSIONS in millimeters				
NOMINAL CASE SIZE L x W x H	CASE CODE	a	b	c
4 x 4 x 5.7	0406	2.6	1.6	1.0
5 x 5 x 5.7	0506	3.0	1.6	1.4
6.3 x 6.3 x 5.7	0606	3.5	1.6	1.9
6.3 x 6.3 x 7.7	0608	3.5	1.6	1.9
8 x 8 x 6.5	0807	4.0	1.6	2.1
8 x 8 x 10	0810	3.5	2.5	3.0
10 x 10 x 10	1010	4.0	2.5	4.0
12.5 x 12.5 x 13	1213	6.0	3.2	4.0

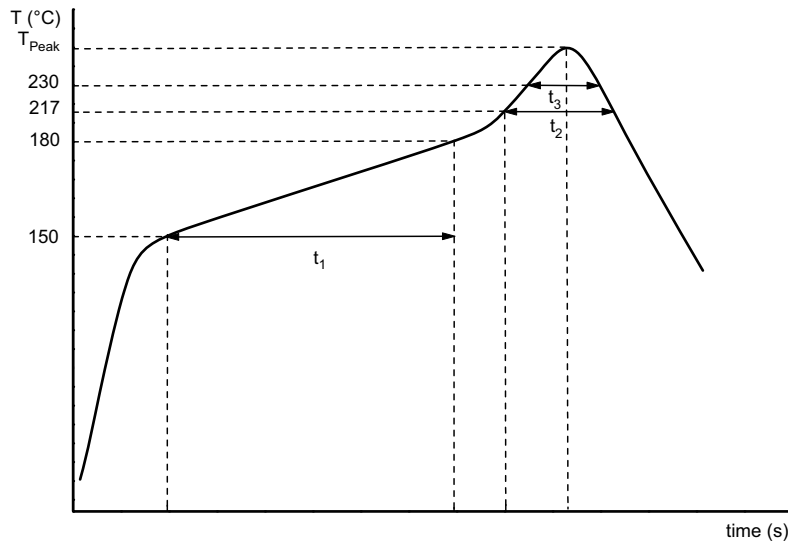

Fig. 5 - Maximum Temperature Load During Reflow Soldering Measured on Capacitors Soldering Pad and Top of Case

Table 4

REFLOW SOLDERING CONDITIONS for MAL214297xxxE3			
PROFILE FEATURES	CASE CODE 0406 to 0608 6.3 V to 50 V	CASE CODE 0406 to 0608 63 V to 100 V	CASE CODE 0807 to 1213 6.3 V to 100 V
Max. time from 25 °C to T_{Peak}	300 s	300 s	300 s
Max. ramp-up rate to 150 °C	3 K/s	3 K/s	3 K/s
Max. time from 150 °C to 180 °C (t_1)	100 s	100 s	100 s
Ramp up rate from 180 °C to T_{Peak}	0.5 K/s to 3 K/s	0.5 K/s to 3 K/s	0.5 K/s to 3 K/s
Max. time from $T_{Liquidus}$ (217 °C) (t_2)	90 s	60 s	60 s
Max. time above 230 °C (t_3)	60 s	30 s	40 s
Peak temperature T_{Peak}	260 °C	250 °C	250 °C
Max. time above T_{Peak} minus 5 °C	5 s	5 s	5 s
Ramp-down rate from $T_{Liquidus}$	3 K/s to 6 K/s	3 K/s to 6 K/s	3 K/s to 6 K/s

Notes

- Temperature measuring point on top of the case and on terminals
- Max. 2 runs with pause of min. 30 min in between



ELECTRICAL DATA	
SYMBOL	DESCRIPTION
C_R	Rated capacitance at 100 Hz or 120 Hz, tolerance $\pm 20\%$
I_R	Rated RMS ripple current at 100 Hz or 120 Hz, 105 °C
I_{L2}	Max. leakage current after 2 min at U_R
$\tan \delta$	Max. dissipation factor at 100 Hz or 120 Hz
Z	Max. impedance at 100 kHz

ORDERING EXAMPLE

Electrolytic capacitor 142 CVZ series

47 μF / 6.3 V; $\pm 20\%$

Nominal case size: 5 mm x 5 mm x 5.7 mm; taped on reel

Ordering code: MAL214297303E3

Note

- Unless otherwise specified, all electrical values in Table 5 apply at $T_{\text{amb}} = 20\text{ °C}$, $P = 86\text{ kPa}$ to 106 kPa , $\text{RH} = 45\%$ to 75%

Table 5

ELECTRICAL DATA AND ORDERING INFORMATION								
U_R (V)	C_R (μF)	NOMINAL CASE SIZE L x W x H (mm)	I_R 105 °C 100 kHz (mA)	I_{L2} 2 min (μA)	Z 100 kHz +20 °C (Ω)	$\tan \delta$ 120 Hz	LIFE CODE (1)	ORDERING CODE MAL2142.....
6.3	22	4 x 4 x 5.7	80	3.0	1.35	0.30	L1	97301E3
	33	4 x 4 x 5.7	80	3.0	1.35	0.30	L1	97302E3
	47	5 x 5 x 5.7	150	3.0	0.80	0.30	L1	97303E3
	100	6.3 x 6.3 x 5.7	230	6.3	0.44	0.30	L1	97304E3
	150	6.3 x 6.3 x 5.7	230	10.0	0.44	0.30	L1	97305E3
	330	8 x 8 x 6.5	280	21.0	0.36	0.30	L1	97308E3
	680	8 x 8 x 10	450	43.0	0.17	0.30	L2	97312E3
	1000	8 x 8 x 10	450	63.0	0.17	0.30	L2	97314E3
	1500	10 x 10 x 10	670	95.0	0.09	0.32	L2	97315E3
	2200	12.5 x 12.5 x 13	820	139.0	0.07	0.34	L2	97316E3
10	22	4 x 4 x 5.7	80	3.0	1.35	0.26	L1	97401E3
	33	5 x 5 x 5.7	150	3.3	0.80	0.26	L1	97402E3
	47	6.3 x 6.3 x 5.7	230	4.7	0.44	0.26	L1	97403E3
	100	6.3 x 6.3 x 5.7	230	10.0	0.44	0.26	L1	97404E3
	150	6.3 x 6.3 x 5.7	230	15.0	0.44	0.26	L1	97405E3
	220	8 x 8 x 6.5	280	22.0	0.36	0.26	L1	97407E3
	1000	10 x 10 x 10	670	100.0	0.09	0.26	L2	97413E3
	1500	12.5 x 12.5 x 13	820	150.0	0.07	0.28	L2	97414E3
16	10	4 x 4 x 5.7	80	3.0	1.35	0.22	L1	97501E3
	22	5 x 5 x 5.7	150	3.6	0.80	0.22	L1	97502E3
	33	6.3 x 6.3 x 5.7	230	5.3	0.44	0.22	L1	97503E3
	47	6.3 x 6.3 x 5.7	230	7.6	0.44	0.22	L1	97504E3
	100	6.3 x 6.3 x 5.7	230	16.0	0.44	0.22	L1	97505E3
	150	6.3 x 6.3 x 7.7	280	24.0	0.36	0.22	L1	97506E3
	220	6.3 x 6.3 x 7.7	280	36.0	0.36	0.22	L1	97508E3
	470	8 x 8 x 10	450	76.0	0.17	0.22	L2	97511E3
	680	10 x 10 x 10	670	109.0	0.09	0.22	L2	97513E3
	1000	12.5 x 12.5 x 13	820	160.0	0.07	0.22	L2	97514E3
25	10	4 x 4 x 5.7	80	3.0	1.35	0.16	L1	97601E3
	22	5 x 5 x 5.7	150	5.5	0.80	0.16	L1	97602E3
	33	6.3 x 6.3 x 5.7	230	8.3	0.44	0.16	L1	97603E3
	47	6.3 x 6.3 x 5.7	230	12.0	0.44	0.16	L1	97604E3
	68	6.3 x 6.3 x 5.7	230	17.0	0.44	0.16	L1	97605E3
	100	6.3 x 6.3 x 7.7	280	25.0	0.36	0.16	L1	97606E3
	150	8 x 8 x 10	450	38.0	0.17	0.16	L2	97608E3
	220	8 x 8 x 10	450	55.0	0.17	0.16	L2	97609E3
	330	8 x 8 x 10	450	83.0	0.17	0.16	L2	97611E3
	470	10 x 10 x 10	670	118.0	0.09	0.16	L2	97612E3
	680	12.5 x 12.5 x 13	820	170.0	0.07	0.16	L2	97613E3



ELECTRICAL DATA AND ORDERING INFORMATION								
U _R (V)	C _R (μF)	NOMINAL CASE SIZE L x W x H (mm)	I _R 105 °C 100 kHz (mA)	I _{L2} 2 min (μA)	Z 100 kHz +20 °C (Ω)	tan δ 120 Hz	LIFE CODE ⁽¹⁾	ORDERING CODE MAL2142.....
35	4.7	4 x 4 x 5.7	80	3.0	1.35	0.13	L1	97001E3
	10	5 x 5 x 5.7	150	3.5	0.80	0.13	L1	97002E3
	22	6.3 x 6.3 x 5.7	230	7.7	0.44	0.13	L1	97003E3
	33	6.3 x 6.3 x 5.7	230	12.0	0.44	0.13	L1	97004E3
	47	6.3 x 6.3 x 5.7	230	17.0	0.44	0.13	L1	97005E3
	68	8 x 8 x 6.5	280	24.0	0.36	0.13	L1	97006E3
	100	8 x 8 x 10	450	35.0	0.17	0.13	L2	97007E3
	150	8 x 8 x 10	450	53.0	0.17	0.13	L2	97008E3
	220	8 x 8 x 10	450	77.0	0.17	0.13	L2	97009E3
	220	10 x 10 x 10	670	77.0	0.09	0.13	L2	97011E3
	330	10 x 10 x 10	670	116.0	0.09	0.13	L2	97012E3
	330	12.5 x 12.5 x 13	820	116.0	0.07	0.13	L2	97013E3
50	1	4 x 4 x 5.7	60	3.0	2.90	0.10	L1	97101E3
	2.2	4 x 4 x 5.7	60	3.0	2.90	0.10	L1	97102E3
	3.3	4 x 4 x 5.7	60	3.0	2.90	0.10	L1	97103E3
	4.7	5 x 5 x 5.7	85	3.0	1.52	0.10	L1	97104E3
	10	6.3 x 6.3 x 5.7	165	5.0	0.88	0.10	L1	97105E3
	22	6.3 x 6.3 x 5.7	165	11.0	0.88	0.10	L1	97106E3
	33	6.3 x 6.3 x 7.7	185	17.0	0.68	0.10	L1	97107E3
	47	6.3 x 6.3 x 7.7	185	24.0	0.68	0.10	L1	97108E3
	68	8 x 8 x 10	369	34.0	0.34	0.10	L2	97109E3
	100	8 x 8 x 10	369	50.0	0.34	0.10	L2	97111E3
	100	10 x 10 x 10	553	50.0	0.18	0.10	L2	97112E3
	150	10 x 10 x 10	553	75.0	0.18	0.10	L2	97113E3
	220	12.5 x 12.5 x 13	650	110.0	0.12	0.10	L2	97114E3
330	12.5 x 12.5 x 13	650	165.0	0.12	0.10	L2	97115E3	
63	4.7	5 x 5 x 5.7	70	3.0	1.90	0.08	L1	97801E3
	10	6.3 x 6.3 x 5.7	130	6.3	1.20	0.08	L1	97802E3
	22	6.3 x 6.3 x 7.7	150	14.0	0.90	0.08	L1	97803E3
	33	8 x 8 x 10	280	21.0	0.50	0.08	L2	97804E3
	47	8 x 8 x 10	280	30.0	0.50	0.08	L2	97805E3
	100	10 x 10 x 10	450	63.0	0.25	0.08	L2	97806E3
	150	12.5 x 12.5 x 13	700	95.0	0.15	0.08	L2	97807E3
	220	12.5 x 12.5 x 13	700	139.0	0.15	0.08	L2	97808E3
80	33	8 x 8 x 10	130	27.0	1.30	0.08	L2	97702E3
	100	10 x 10 x 10	200	80.0	0.70	0.08	L2	97704E3
	150	12.5 x 12.5 x 13	450	120.0	0.32	0.08	L2	97705E3
100	22	8 x 8 x 10	130	22.0	1.30	0.07	L2	97901E3
	33	10 x 10 x 10	200	33.0	0.70	0.07	L2	97902E3
	47	10 x 10 x 10	200	47.0	0.70	0.07	L2	97903E3
	100	12.5 x 12.5 x 13	450	100.0	0.32	0.07	L2	97904E3

Note

⁽¹⁾ Determines the applicable row in the table "Endurance Test Duration and Useful Life"

Table 6

ADDITIONAL ELECTRICAL DATA		
PARAMETER	CONDITIONS	VALUE
Voltage		
Surge voltage	IEC 60384-18, subclause 4.14	$U_S < 1.15 \times U_R$
Reverse voltage for short periods	IEC 60384-18, subclause 4.16	$U_{rev} < 1 V$
Current		
Leakage current	After 2 min at U_R	$I_{L2} < 0.01 \times C_R \times U_R$ or $3 \mu A$ whichever is greater
Inductance		
Equivalent series inductance (ESL) at 1 MHz	Case codes 0406 to 0608	Typ. 6 nH
	Case codes 0807 to 1010	Typ. 9 nH
	Case code 1213	Typ. 1 nH
Resistance		
Equivalent series resistance (ESR) at 100 Hz function of frequency	Calculated from $\tan \delta_{max}$ and C_R (see Table 5)	$ESR = \tan \delta / 2\pi f C_R$

RIPPLE CURRENT AND USEFUL LIFE

Table 7

ENDURANCE TEST DURATION AND USEFUL LIFE			
LIFE CODE	ENDURANCE AT 105 °C (h)	USEFUL LIFE AT 105 °C (h)	USEFUL LIFE AT 40°C 1.8 x I_R APPLIED (h)
L1	1000	2000	100 000
L2	3000	5000	250 000

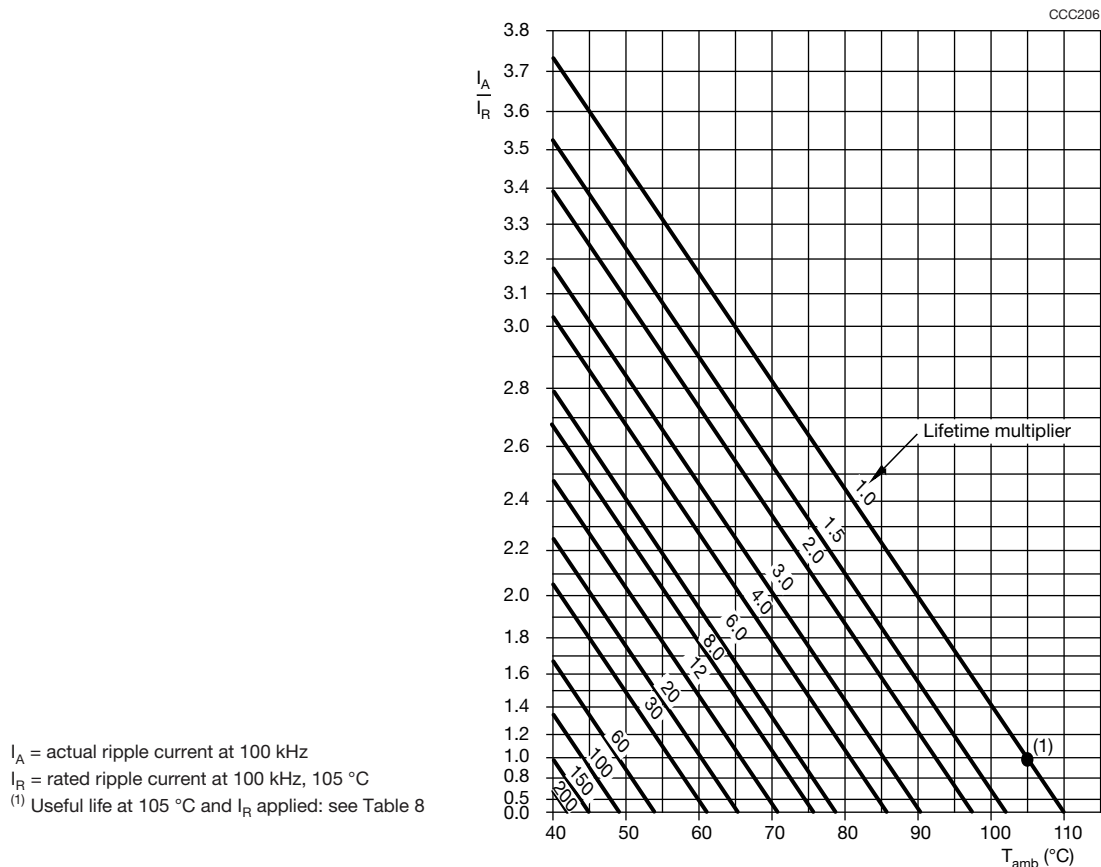

Fig. 6 - Multiplier of useful life as a function of ambient temperature and ripple current load



Table 8

MULTIPLIER OF RIPPLE CURRENT (I_R) AS A FUNCTION OF FREQUENCY			
FREQUENCY (Hz)			
50	100	1000	$\geq 10\ 000$
I_R MULTIPLIER			
0.60	0.70	0.85	1.0

Table 9

TEST PROCEDURES AND REQUIREMENTS			
TEST		PROCEDURE (quick reference)	REQUIREMENTS
NAME OF TEST	REFERENCE		
Mounting	IEC 60384-18, subclause 4.3	Shall be performed prior to tests mentioned below; reflow soldering; for maximum temperature load refer to chapter "Mounting"	$\Delta C/C: \pm 10\ %$ $\tan \delta \leq \text{spec. limit}$ $I_{L2} \leq \text{spec. limit}$
Endurance	IEC 60384-18 / CECC 32300, subclause 4.15	$T_{\text{amb}} = 105\ ^\circ\text{C}$; U_R applied; for test duration see Table 7	$\Delta C/C: \pm 20\ %$ $\tan \delta \leq 2 \times \text{spec. limit}$ $I_{L2} \leq \text{spec. limit}$
Useful life	CECC 30301, subclause 1.8.1	$T_{\text{amb}} = 105\ ^\circ\text{C}$; U_R and I_R applied; for test duration see Table 87	$\Delta C/C: \pm 50\ %$ $\tan \delta \leq 3 \times \text{spec. limit}$ $I_{L2} \leq \text{spec. limit}$ no short or open circuit total failure percentage: $\leq 1\ %$
Shelf life (storage at high temperature)	IEC 60384-18 / CECC 32300, subclause 4.17	$T_{\text{amb}} = 105\ ^\circ\text{C}$; no voltage applied; 1000 h after test: U_R to be applied for 30 min, 24 h to 48 h before measurement	For requirements see "Endurance test" above

Statements about product lifetime are based on calculations and internal testing. They should only be interpreted as estimations. Also due to external factors, the lifetime in the field application may deviate from the calculated lifetime. In general, nothing stated herein shall be construed as a guarantee of durability.



Disclaimer

ALL PRODUCT, PRODUCT SPECIFICATIONS AND DATA ARE SUBJECT TO CHANGE WITHOUT NOTICE TO IMPROVE RELIABILITY, FUNCTION OR DESIGN OR OTHERWISE.

Vishay Intertechnology, Inc., its affiliates, agents, and employees, and all persons acting on its or their behalf (collectively, "Vishay"), disclaim any and all liability for any errors, inaccuracies or incompleteness contained in any datasheet or in any other disclosure relating to any product.

Vishay makes no warranty, representation or guarantee regarding the suitability of the products for any particular purpose or the continuing production of any product. To the maximum extent permitted by applicable law, Vishay disclaims (i) any and all liability arising out of the application or use of any product, (ii) any and all liability, including without limitation special, consequential or incidental damages, and (iii) any and all implied warranties, including warranties of fitness for particular purpose, non-infringement and merchantability.

Statements regarding the suitability of products for certain types of applications are based on Vishay's knowledge of typical requirements that are often placed on Vishay products in generic applications. Such statements are not binding statements about the suitability of products for a particular application. It is the customer's responsibility to validate that a particular product with the properties described in the product specification is suitable for use in a particular application. Parameters provided in datasheets and / or specifications may vary in different applications and performance may vary over time. All operating parameters, including typical parameters, must be validated for each customer application by the customer's technical experts. Product specifications do not expand or otherwise modify Vishay's terms and conditions of purchase, including but not limited to the warranty expressed therein.

Hyperlinks included in this datasheet may direct users to third-party websites. These links are provided as a convenience and for informational purposes only. Inclusion of these hyperlinks does not constitute an endorsement or an approval by Vishay of any of the products, services or opinions of the corporation, organization or individual associated with the third-party website. Vishay disclaims any and all liability and bears no responsibility for the accuracy, legality or content of the third-party website or for that of subsequent links.

Except as expressly indicated in writing, Vishay products are not designed for use in medical, life-saving, or life-sustaining applications or for any other application in which the failure of the Vishay product could result in personal injury or death. Customers using or selling Vishay products not expressly indicated for use in such applications do so at their own risk. Please contact authorized Vishay personnel to obtain written terms and conditions regarding products designed for such applications.

No license, express or implied, by estoppel or otherwise, to any intellectual property rights is granted by this document or by any conduct of Vishay. Product names and markings noted herein may be trademarks of their respective owners.