

SMD PTC Thermistors For Overload Protection



FEATURES

- Compact resettable overload protection
- Low mounting height
- Suitable for reflow soldering
- Small ceramic diameter for faster response
- Low heat transfer to substrate
- Flat terminations for stable positioning and good solderability
- Material categorization: for definitions of compliance please see www.vishay.com/doc?99912

RoHS
COMPLIANT

APPLICATIONS

Over-temperature/over-load protection:

- Telecom
 - Central Office Switching (C.O.)
 - Subscriber Terminal Equipment (T.E.)
 - Set-top Box
 - Modems
- General industry and automotive
 - Low power overload protection
 - Inrush current limitation

DESCRIPTION

The component consists of a high performance PTC ceramic mounted in a lead frame with lead (Pb)-free tin plated contacts. The terminations are joined to the Ag plated ceramic by a high melting solder. The ceramic is covered with a protective high temperature silicone layer.

MARKING

- All SMD PTCs are marked with a 3-digit type number (XXX) and a date code (YYWW)

| QUICK REFERENCE DATA | | | |
|--|-------------------------------|------------------------------|-----------|
| PARAMETER | VALUE | | UNIT |
| | STANDARD TYPES ⁽¹⁾ | TELECOM TYPES ⁽¹⁾ | |
| Resistance value at 25 °C | 2 to 500 | 10 to 70 | Ω |
| Tolerance on R_{25} value | ± 10; ± 15; ± 20 | | % |
| Maximum overload current I_{ol} (V_{max} . dependent) | 2 to 10 | | A |
| Maximum holding current (I_{ht}) | 50 to 500 (at 25 °C) | 50 to 100 (at 70 °C) | |
| Maximum voltage (RMS or DC) | 16 to 400 | 220 to 600 | V_{RMS} |
| Maximum trip time at 1 A | 0.8 to 6 | | s |
| Switching temperature (T_{sw}) | 105 to 140 | | °C |
| Operating temperature range at max. voltage | -40 to 85 | | |
| Storage temperature | -40 to 155 | | |
| Maximum continuous power at 25 °C | 2 | | W |

Note

- ⁽¹⁾ Customized products are available on request in the indicated nominal R_{25} range. Larger 8 mm ceramics for lower resistance values or higher voltages are in use in the PTCCZ08 series.

| ELECTRICAL DATA AND ORDERING INFORMATION | | | | | | | | | | | | | |
|--|-----------|--------------|---------------|-------------|------------|---------------------|---------------------------|--------------------------------|----------|---------------------------------------|---------------------|-------------------------------|-----------------|
| RESISTANCE | | MATCHING (Ω) | V_{max} (V) | I_{ht} at | | I_t at 25 °C (mA) | MAX. TRIP-TIME at 1 A (s) | MAX. I_{ol} at V_{max} (A) | T_{sw} | OPERATING TEMP. RANGE AT MAX. VOLTAGE | STORAGE TEMP. RANGE | CATALOG NUMBER | |
| R_{25} (Ω) | TOL. (%) | | | 25 °C (mA) | 70 °C (mA) | | | | | | | SAP ORDERING CODE | TYPE NR MARKING |
| TELECOM AND INDUSTRIAL TYPES | | | | | | | | | | | | | |
| 10 | 20 | - | 245 | 165 | 100 | 270 | 3.0 | 2.0 | 105 | 0 to 70 | -25 to 125 | PTCTZ3NR100GTT ⁽²⁾ | 012 |
| 10 | 20 | 0.5 | 245 | 165 | 100 | 270 | 3.0 | 2.0 | 105 | 0 to 70 | -25 to 125 | PTCTZ3MR100GTT ⁽²⁾ | 016 |
| 40 | 25 | no | 265 | 80 | 50 | 130 | 0.8 | 2.0 | 105 | 0 to 70 | -25 to 125 | PTCTZ3NR400HTT | 002 |
| 25 | 20 | 1 | 265 | 120 | 70 | 220 | 1.3 | 2.0 | 110 | 0 to 70 | -25 to 125 | PTCTZ3MR250HTT ⁽²⁾ | 005 |
| 15 to 20 | - | - | 300 | 150 | 100 | 250 | 1.5 | 1.5 | 115 | 0 to 70 | -25 to 125 | PTCTZ3NR150KTT ⁽²⁾ | 004 |
| 15 to 20 | - | 0.5 | 300 | 150 | 100 | 250 | 1.5 | 2.0 | 115 | 0 to 70 | -25 to 125 | PTCTZ3MR150KTT ⁽²⁾ | 003 |
| 20 | 20 | 0.5 | 300 | 120 | 70 | 250 | 1.4 | 1.5 | 105 | 0 to 70 | -25 to 125 | PTCTZ3MR200KTT ⁽²⁾ | 018 |
| 35 | +15 / -20 | 1 | 425 | 110 | 70 | 175 | 1.0 | 0.7 | 125 | -25 to 85 | -40 to 155 | PTCTZ3MR350MTT ⁽²⁾ | 009 |
| 50 | 20 | 1 | 425 | 90 | 60 | 150 | 0.8 | 0.7 | 125 | -40 to 70 | -40 to 125 | PTCTZ3MR500MTT | 019 |
| GENERAL INDUSTRIAL TYPES | | | | | | | | | | | | | |
| 3.3 | 25 | - | 24 | 400 | - | 650 | 6.0 | 8.0 | 140 | -40 to 85 | -40 to 155 | PTCTZ3NR339CTT | 013 |
| 9.4 | 25 | - | 60 | 150 | 100 | 300 | 1.8 | 3.0 | 115 | -40 to 85 | -40 to 155 | PTCTZ3NR949ETT | 011 |

Note

- ⁽²⁾ These types pass ITU-K20-21-45 telecommunication protection recommendation

PTC OUTLINES

PTC SMD ceramic size: 6.5 mm

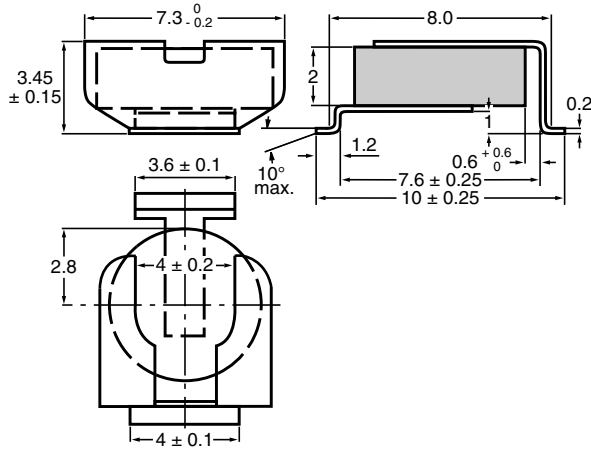
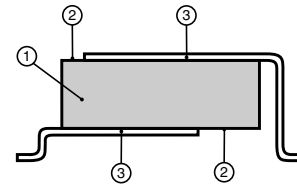
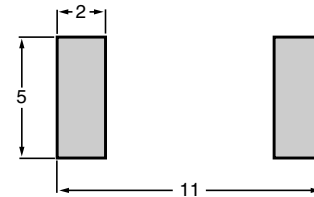
DIMENSIONS in millimeters

DIMENSIONS OF SOLDER LANDS in millimeters

| PACKAGING | | | | | |
|-----------|----------|--|-------|-------|---------------|
| TYPE | QUANTITY | CARRIER TAPE | WIDTH | PITCH | REEL DIAMETER |
| PTCTZ | 1500 | PS conductive blister tape acc. IEC60286-3 | 16 mm | 12 mm | 330 mm |

| MATERIAL INFORMATION | | |
|----------------------|--------------|---|
| REF. | DESCRIPTION | MATERIAL AND REMARKS |
| 1 | Ceramic | BaTiO ₃ doped |
| 2 | Metalization | NiCr Ag layer (vacuum deposition) |
| 3 | Lead frame | Ni plated phosphor bronze material covered by matte tin layer |

SOLDERING CONDITIONS

This SMD thermistor is only suitable for reflow soldering, in accordance with JEDEC J-STD-020D. Soldering processes which can be used are reflow (infrared and convection heating) and vapor phase. The maximum temperature of 260 °C during 10 s should not be exceeded and no liquid flux should be allowed to reach the ceramic body.

Typical examples of a soldering processes that will provide reliable joints without damage, are shown below.

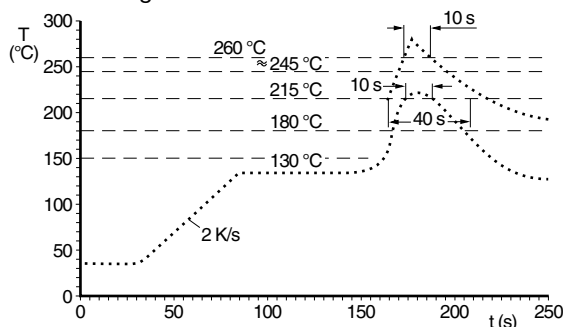
Reflow soldering

Typical values (solid line)
Process limits (dotted lines)

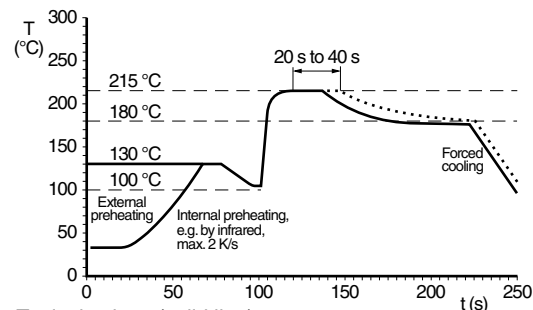
Vapor phase soldering

Typical values (solid line)
Process limits (dotted lines)

MOUNTING CONDITIONS

A flat pick-up area of minimum 10 mm² and low weight allows for fast placement.

Because of the nature of PTC ceramic material the component should not be touched with bare hands, as the residue of perspiration can influence component behavior at high temperatures.

Handling forces applied to the component should be limited to 5 N in any condition.



Disclaimer

ALL PRODUCT, PRODUCT SPECIFICATIONS AND DATA ARE SUBJECT TO CHANGE WITHOUT NOTICE TO IMPROVE RELIABILITY, FUNCTION OR DESIGN OR OTHERWISE.

Vishay Intertechnology, Inc., its affiliates, agents, and employees, and all persons acting on its or their behalf (collectively, "Vishay"), disclaim any and all liability for any errors, inaccuracies or incompleteness contained in any datasheet or in any other disclosure relating to any product.

Vishay makes no warranty, representation or guarantee regarding the suitability of the products for any particular purpose or the continuing production of any product. To the maximum extent permitted by applicable law, Vishay disclaims (i) any and all liability arising out of the application or use of any product, (ii) any and all liability, including without limitation special, consequential or incidental damages, and (iii) any and all implied warranties, including warranties of fitness for particular purpose, non-infringement and merchantability.

Statements regarding the suitability of products for certain types of applications are based on Vishay's knowledge of typical requirements that are often placed on Vishay products in generic applications. Such statements are not binding statements about the suitability of products for a particular application. It is the customer's responsibility to validate that a particular product with the properties described in the product specification is suitable for use in a particular application. Parameters provided in datasheets and / or specifications may vary in different applications and performance may vary over time. All operating parameters, including typical parameters, must be validated for each customer application by the customer's technical experts. Product specifications do not expand or otherwise modify Vishay's terms and conditions of purchase, including but not limited to the warranty expressed therein.

Hyperlinks included in this datasheet may direct users to third-party websites. These links are provided as a convenience and for informational purposes only. Inclusion of these hyperlinks does not constitute an endorsement or an approval by Vishay of any of the products, services or opinions of the corporation, organization or individual associated with the third-party website. Vishay disclaims any and all liability and bears no responsibility for the accuracy, legality or content of the third-party website or for that of subsequent links.

Except as expressly indicated in writing, Vishay products are not designed for use in medical, life-saving, or life-sustaining applications or for any other application in which the failure of the Vishay product could result in personal injury or death. Customers using or selling Vishay products not expressly indicated for use in such applications do so at their own risk. Please contact authorized Vishay personnel to obtain written terms and conditions regarding products designed for such applications.

No license, express or implied, by estoppel or otherwise, to any intellectual property rights is granted by this document or by any conduct of Vishay. Product names and markings noted herein may be trademarks of their respective owners.