

NTC Thermistors, Miniature Immersion Sensor



LINKS TO ADDITIONAL RESOURCES



QUICK REFERENCE DATA		
PARAMETER	VALUE	UNIT
Resistance value at 25 °C	10K	Ω
Tolerance on R_{25} -value	± 3	%
$B_{25/85}$ -value	3984	K
Tolerance on $B_{25/85}$ -value	± 0.5	%
Operating temperature range at zero dissipation	-25 to +105	°C
Response time $t_{63.2\% \Delta T}$ (air 25 °C to water 85 °C)	1.5	s
Dissipation factor δ		mW/K
Mounted in still air	2.8	
In still water	5.6	
Maximum power dissipation at 55 °C	100	mW
Min. dielectric withstanding voltage between terminals and capsule (10 s)	500	V _{AC}
Insulation resistance at 500 V _{DC}	> 100M	Ω
Thermal gradient	< 0.02	K/K
Weight	2.1	g

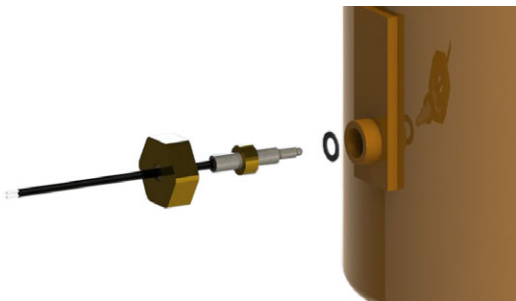

Fig. 1 - Mounting example with sealing ring and screw

FEATURES

- Fast time response for fluid immersion applications
- Reduced thermal gradient, due to the use of small tip dimensions and thin insulated wire
- Sensor for permanent contact with water or other liquids
- Material categorization: for definitions of compliance please see www.vishay.com/doc?99912



RoHS COMPLIANT

APPLICATIONS

Immersion sensor used for temperature measurement, sensing and control in:

- Water boilers
- Heating systems
- Chiller systems
- Water and used water systems
- Water and oil tanks
- Consumer appliances, coffee machines
- Industrial appliances
- Solar heating systems

DESCRIPTION

Miniature insulated chip NTC thermistor mounted in a SS304 or SS316 housing with or without brass collar for sealed mounting and twin PVC insulated AWG#30 lead wire connection.

MOUNTING

- The sensor can be mounted by means of a sealing O-ring and screw
- The end wire can be soldered, or crimped to a connector
- Optional connector for Wire-to-Wire or Wire-to-Board connections
- The contact area with the liquid is preferably min 10 mm down from the tip and max to the brass collar location (see Fig. 1 for mounting example)
- Not intended for corrosive or high acidic liquids
- The epoxy lead-wire side can not be in permanent contact with liquids, or water

PACKAGING

Available in plastic bags of 250 pieces.

DESIGN-IN SUPPORT

- Other resistance curves and tolerances are available on request
- Consult Vishay for other lead length or connector options
- For complete RT curve computation, visit: www.vishay.com/thermistors/ntc-rt-calculator/

ELECTRICAL DATA AND ORDERING INFORMATION						
R_{25} (Ω)	R_{25} -TOL. (%)	$B_{25/85}$ (K)	$B_{25/85}$ -TOL. (± %)	DESCRIPTION	SAP MATERIAL AND ORDERING NUMBER	
					RoHS-COMPLIANT WITH EXEMPTION	RoHS-COMPLIANT
10 000	± 3	3984	0.5	NTC Immersion 10K 3 % 3984K 0.5 %	NTCAIMME3C90373 ⁽¹⁾⁽²⁾	NTCAIMME3C90373A ⁽³⁾
10 000	± 3	3984	0.5	NTC 10K 3 % 3984K 0.5 % no ring	NTCAIMME3C90686 ⁽¹⁾	NTCAIMME3C90686A ⁽³⁾

Notes

 Preferred versions for new designs

- Preferred types are marked in **bold**

- (1) RoHS exemption 7(c)-I: electrical and electronic components containing lead in a glass or ceramic other than dielectric ceramic in capacitors, e.g. piezo-electronic devices, or in a glass or ceramic matrix compound
- (2) RoHS exemption 6(c): copper alloy containing up to 4 % lead by weight (brass material)
- (3) Stainless steel SS316 housing. Ring is lead (Pb)-free brass material where applicable

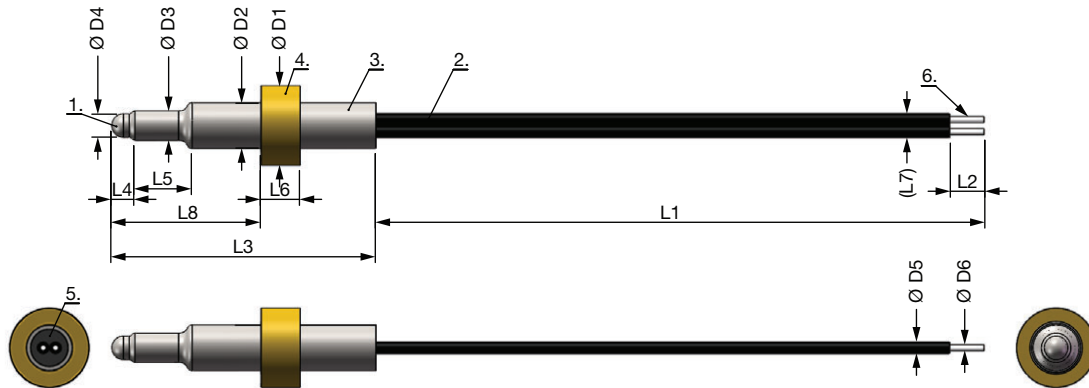
DIMENSIONS in millimeters

L1	L2	L3	L4	L5	L6	L7	L8	Ø D1	Ø D2	Ø D3	Ø D4	Ø D5	Ø D6
200 ± 20	4 ± 1	23 ± 0.5	2 ± 0.5	5 ± 0.5	3.4 ± 0.2	2.05	13 ± 0.5	6.8 ± 0.1	3.9 ± 0.1	2.5 ± 0.2	2 ± 0.2	1	0.3

Notes

1. Vishay Thermistor chip NTC, epoxy insulated
2. PVC cable, single insulated 105 °C, 300 V rated, AWG#30 multi-stranded twin
3. Stainless steel (SS304) housing
4. Brass collar (not present on the NTCAIMME3C90686 type)
5. Epoxy potting resin
6. Pre-tinned end wire stripped

 For complete Curve Computation, visit: www.vishay.com/thermistors/ntc-rt-calculator/

RESISTANCE TEMPERATURE CHARACTERISTICS							
TEMP. (°C)	$R_{(T)}/R_{25}$	RESISTANCE (Ω)	$\Delta R/R$ (%)	α (%/K)	ΔT (K)	$R_{MIN.}$ (Ω)	$R_{MAX.}$ (Ω)
-25	12.990	129 900	4.39	-5.99	0.73	124 202	135 598
-20	9.676	96 761	4.22	-5.79	0.73	92 675	100 848
-15	7.276	72 765	4.07	-5.61	0.73	69 806	75 723
-10	5.522	55 218	3.92	-5.43	0.72	53 056	57 380
-5	4.227	42 268	3.77	-5.26	0.72	40 674	43 861
0	3.262	32 624	3.63	-5.10	0.71	31 440	33 808
5	2.538	25 381	3.49	-4.94	0.71	24 494	26 268
10	1.990	19 897	3.36	-4.80	0.70	19 227	20 566
15	1.571	15 711	3.24	-4.65	0.70	15 202	16 220
20	1.249	12 493	3.12	-4.52	0.69	12 103	12 882
25	1.000	10 000	3.00	-4.39	0.68	9700.0	10 300
30	0.8056	8056.0	3.11	-4.26	0.73	7805.1	8306.8
35	0.6530	6529.7	3.22	-4.14	0.78	6319.3	6740.2
40	0.5324	5323.9	3.33	-4.03	0.83	5146.6	5501.1
45	0.4365	4365.3	3.43	-3.92	0.88	4215.4	4515.1
50	0.3599	3598.7	3.53	-3.81	0.93	3471.6	3725.8
55	0.2982	2982.3	3.63	-3.71	0.98	2874.0	3090.5
60	0.2484	2483.8	3.72	-3.61	1.03	2391.3	2576.3
65	0.2079	2078.7	3.81	-3.51	1.09	1999.4	2157.9
70	0.1748	1747.7	3.90	-3.42	1.14	1679.5	1815.9
75	0.1476	1475.9	3.99	-3.34	1.20	1417.1	1534.8
80	0.1252	1251.8	4.07	-3.25	1.25	1200.8	1302.8
85	0.1066	1066.1	4.15	-3.17	1.31	1021.8	1110.4
90	0.09116	911.59	4.23	-3.09	1.37	873.01	950.16
95	0.07825	782.46	4.31	-3.02	1.43	748.75	816.17
100	0.06741	674.11	4.38	-2.94	1.49	644.56	703.66
105	0.05828	582.84	4.46	-2.87	1.55	556.87	608.82



Disclaimer

ALL PRODUCT, PRODUCT SPECIFICATIONS AND DATA ARE SUBJECT TO CHANGE WITHOUT NOTICE TO IMPROVE RELIABILITY, FUNCTION OR DESIGN OR OTHERWISE.

Vishay Intertechnology, Inc., its affiliates, agents, and employees, and all persons acting on its or their behalf (collectively, "Vishay"), disclaim any and all liability for any errors, inaccuracies or incompleteness contained in any datasheet or in any other disclosure relating to any product.

Vishay makes no warranty, representation or guarantee regarding the suitability of the products for any particular purpose or the continuing production of any product. To the maximum extent permitted by applicable law, Vishay disclaims (i) any and all liability arising out of the application or use of any product, (ii) any and all liability, including without limitation special, consequential or incidental damages, and (iii) any and all implied warranties, including warranties of fitness for particular purpose, non-infringement and merchantability.

Statements regarding the suitability of products for certain types of applications are based on Vishay's knowledge of typical requirements that are often placed on Vishay products in generic applications. Such statements are not binding statements about the suitability of products for a particular application. It is the customer's responsibility to validate that a particular product with the properties described in the product specification is suitable for use in a particular application. Parameters provided in datasheets and / or specifications may vary in different applications and performance may vary over time. All operating parameters, including typical parameters, must be validated for each customer application by the customer's technical experts. Product specifications do not expand or otherwise modify Vishay's terms and conditions of purchase, including but not limited to the warranty expressed therein.

Hyperlinks included in this datasheet may direct users to third-party websites. These links are provided as a convenience and for informational purposes only. Inclusion of these hyperlinks does not constitute an endorsement or an approval by Vishay of any of the products, services or opinions of the corporation, organization or individual associated with the third-party website. Vishay disclaims any and all liability and bears no responsibility for the accuracy, legality or content of the third-party website or for that of subsequent links.

Vishay products are not designed for use in life-saving or life-sustaining applications or any application in which the failure of the Vishay product could result in personal injury or death unless specifically qualified in writing by Vishay. Customers using or selling Vishay products not expressly indicated for use in such applications do so at their own risk. Please contact authorized Vishay personnel to obtain written terms and conditions regarding products designed for such applications.

No license, express or implied, by estoppel or otherwise, to any intellectual property rights is granted by this document or by any conduct of Vishay. Product names and markings noted herein may be trademarks of their respective owners.