

Power Metal Strip® Resistors, Very High Power (to 12 W), Low Value (Down to 0.0002 Ω), Surface Mount

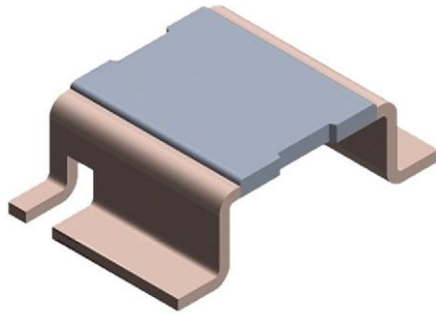

FEATURES

- High power to foot print size ratio
- All welded construction of the Power Metal Strip® resistors are ideal for all types of current sensing, voltage division and pulse applications
- Proprietary processing technique produces extremely low resistance values, down to 0.0002 Ω
- Sulfur resistance by construction that is unaffected by high sulfur environments
- Specially selected and stabilized materials allow for high power rating (to 12 W)
- Solid metal nickel-chrome or manganese-copper alloy resistive element with low TCR (< 20 ppm/°C)
- Very low inductance 0.5 nH to 5 nH
- Low thermal EMF (< 3 μV/°C)
- AEC-Q200 qualified ⁽¹⁾
- Material categorization: for definitions of compliance please see www.vishay.com/doc?99912

 AUTOMOTIVE
GRADE

RoHS
COMPLIANT
HALOGEN
FREE
GREEN
(5-2008)

LINKS TO ADDITIONAL RESOURCES



Notes

- Follow link to Overview of Automotive Grade Products for more details: www.vishay.com/doc?49924
- ⁽¹⁾ Flame retardance test may not be applicable to some resistor technologies

STANDARD ELECTRICAL SPECIFICATIONS

GLOBAL MODEL	SIZE	POWER RATING $P_{70^{\circ}\text{C}}$ W	TOLERANCE ± %	RESISTANCE VALUE RANGE Ω	RESISTANCE VALUES CURRENTLY AVAILABLE ⁽¹⁾ Ω	WEIGHT (typical) g/1000 pieces
WSLP4026	4026	5.0	1.0, 5.0	1.3m to 5m	1.3m, 2m, 3m, 4m, 5m	420
WSLP4026	4026	7.0	1.0, 5.0	0.5m to 1m	0.5m, 0.7m, 1m	420
WSLP4026	4026	10.0	1.0, 5.0	0.3m	0.3m	420
WSLP4026	4026	12.0	1.0, 5.0	0.2m	0.2m	420

Notes

- Power rating depends on the max. temperature at the solder point, component placement density and the substrate material
- Part marking: model, value, tolerance, date code
- ⁽¹⁾ Other values may be available, contact factory

GLOBAL PART NUMBER INFORMATION

Global Part Numbering Example: WSLP4026L5000FEA (WSLP4026, 0.0005 Ω, ± 1 %)

 (visit www.vishay.net Vishay Dale parts numbering manual for all options)

W	S	L	P	4	0	2	6	L	5	0	0	0	F	E	A		
---	---	---	---	---	---	---	---	---	---	---	---	---	---	---	---	--	--

GLOBAL MODEL (8 digits)
WSLP4026

RESISTANCE VALUE (5 digits)
L = mΩ
L5000 = 0.0005 Ω
L7000 = 0.0007 Ω
1L000 = 0.0010 Ω
2L000 = 0.0020 Ω

TOLERANCE CODE (1 digit)
F = ± 1.0 %
J = ± 5.0 %

PACKAGING CODE ⁽¹⁾ (2 digits)
EA = lead (Pb)-free, tape / reel
EK = lead (Pb)-free, bulk

SPECIAL ⁽²⁾ (up to 2 digits)
(dash number) (up to 2 digits) from 1 to 99 as applicable

Notes

- ⁽¹⁾ Packaging code: EB (lead (Pb)-free) is a non-standard packaging code designating 1000 piece reels. The non-standard packaging code is identical to our standard EA (lead (Pb)-free), except that it is a package quantity of 1000 pieces
- ⁽²⁾ Follow link for customization capabilities: www.vishay.com/doc?48163

TECHNICAL SPECIFICATIONS		
PARAMETER	UNIT	RESISTOR CHARACTERISTICS
Component temperature coefficient (including terminal) ⁽¹⁾ TCR measured from -55 °C to 150 °C	ppm/°C	± 75 for 0.5 mΩ to 5 mΩ
		± 110 for 0.3 mΩ; ± 75 for 0.2 mΩ
Element TCR ⁽²⁾	ppm/°C	< 20
Operating temperature range	°C	-65 to +170
Maximum working voltage ⁽³⁾	V	$(P \times R)^{1/2}$

Notes

- (1) Component TCR - total TCR that includes the TCR effects of the resistor element and the copper terminal
- (2) Element TCR - only applies to the alloy used for the resistor element
- (3) Maximum working voltage - the WSL is not voltage sensitive, but is limited by power / energy dissipation and is also not ESD sensitive

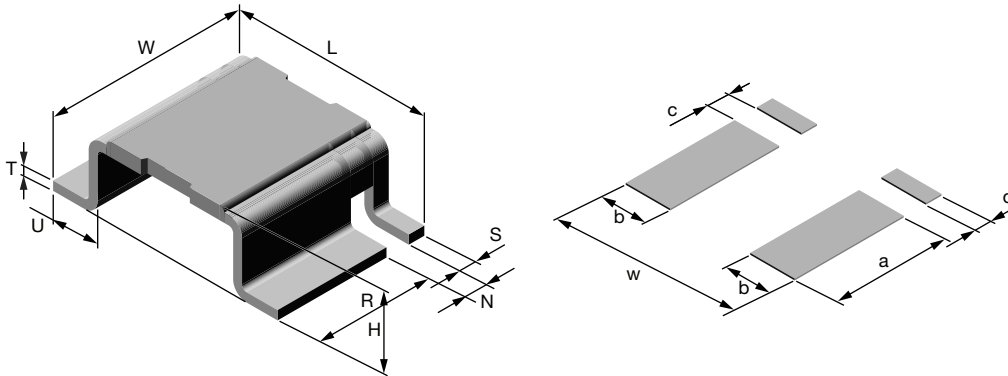
DIMENSIONS in inches (millimeters)

Notes

- 3D models available: www.vishay.com/doc?30316
- Surface mount solder profile recommendations: www.vishay.com/doc?31052

MODEL	DIMENSIONS							
	L	W	H	R (REF.)	S	T	U	N
WSLP4026	0.400 ± 0.008 (10.1 ± 0.2)	0.260 + 0.012/- 0.008 (6.6 + 0.3/- 0.2)	Please see table below	0.198 (5.0)	0.028 ± 0.004 (0.7 ± 0.1)	0.016 ± 0.002 (0.4 ± 0.05)	0.078 ± 0.004 (2.0 ± 0.1)	0.039 ± 0.006 (0.99 ± 0.15)

MODEL	SOLDER PAD DIMENSIONS				
	a	b	c	d	w
WSLP4026	0.220 (5.6)	0.096 (2.44)	0.035 (0.89)	0.035 (0.89)	0.420 (10.6)

MODEL	RESISTANCE VALUE (mΩ)	THERMAL RESISTANCE ⁽¹⁾ (°C/W)	ELEMENT MATERIAL	HEIGHT H
WSLP4026	0.2	3	Mn-Cu-Sn	0.150 ± 0.008 (3.81 ± 0.2)
	0.3	4	Mn-Cu	0.141 ± 0.008 (3.58 ± 0.2)
	0.5	6	Mn-Cu	0.116 ± 0.008 (2.95 ± 0.2)
	0.7	8	Mn-Cu	0.111 ± 0.008 (2.82 ± 0.2)
	1.0	10	Mn-Cu	0.1055 ± 0.008 (2.68 ± 0.2)
	1.3	11	Ni-Cr	0.119 ± 0.008 (3.02 ± 0.2)
	2.0	16	Ni-Cr	0.114 ± 0.008 (2.9 ± 0.2)
	3.0	19	Ni-Cr	0.110 ± 0.008 (2.79 ± 0.2)
	4.0	22	Ni-Cr	0.110 ± 0.008 (2.79 ± 0.2)
5.0	38	Ni-Cr	0.110 ± 0.008 (2.79 ± 0.2)	

Note

- (1) The full power rating of Power Metal Strip resistors are dependent upon the ability of the circuit board to dissipate the heat energy created in the resistance element. It is recommended to follow common design practices for power semiconductors that ensure the junction temperature is maintained within thermal limits by using large pad surfaces, thermal vias, heavier copper weights, internal layers as well as other thermal spreading features. The thermal resistance values provided function in the same manner as junction to terminal temperature



DERATING - AMBIENT TEMPERATURE

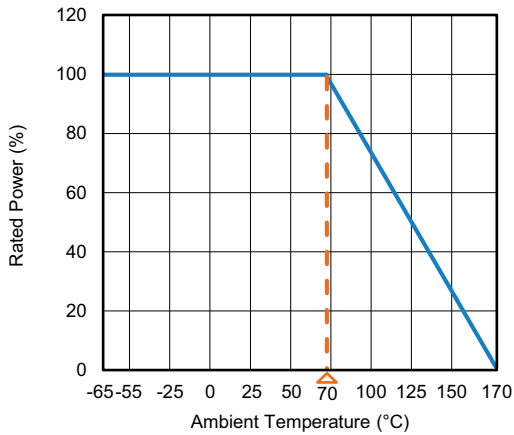

DERATING - TERMINAL TEMPERATURE

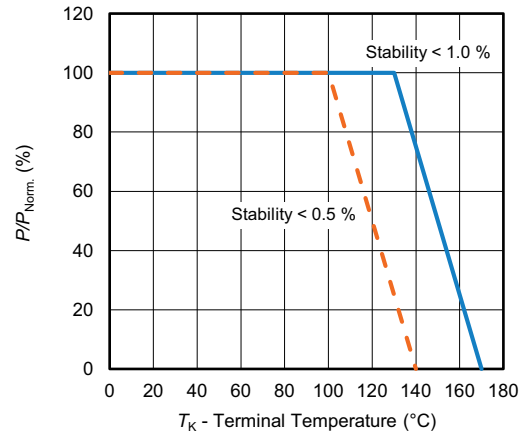

Example: WSLP4026 0.0005 Ω , 0.001 Ω

PULSE CAPABILITY

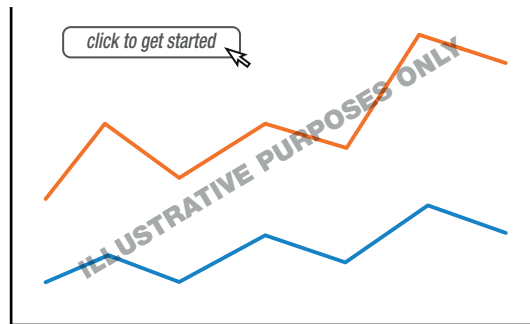

www.vishay.com/resistors/power-metal-strip-calculator

PERFORMANCE		
TEST	CONDITIONS OF TEST	TEST LIMITS
Thermal shock	-55 °C to +150 °C, 1000 cycles, 15 min at each extreme	± 0.5 %
Low temperature operation	-65 °C for 24 h	± 0.5 %
High temperature exposure	1000 h at +170 °C	± 1.0 %
Bias humidity	+85 °C, 85 % RH, 10 % bias, 1000 h	± 0.5 %
Mechanical shock	100 g's for 6 ms, 5 pulses	± 0.5 %
Vibration	Frequency varied 10 Hz to 2000 Hz in 1 min, 3 directions, 12 h	± 0.5 %
Load life	1000 h at +70 °C, 1.5 h "ON", 0.5 h "OFF"	± 1.0 %
Resistance to solder heat	3 x at 250 °C ± 5 °C for 30 s ± 5 s	± 0.5 %
Moisture resistance	MIL-STD-202, method 106, 0 % power, 7b not required	± 0.5 %



PACKAGING (1)				
MODEL	REEL			
	TAPE WIDTH	DIAMETER	PIECES/REEL	CODE
WSLP4026	24 mm / embossed plastic	330 mm / 13"	1500	EA

Notes

- Embossed carrier tape per EIA-481
- (1) Additional packaging details at www.vishay.com/doc?20051

REEL ORIENTATION

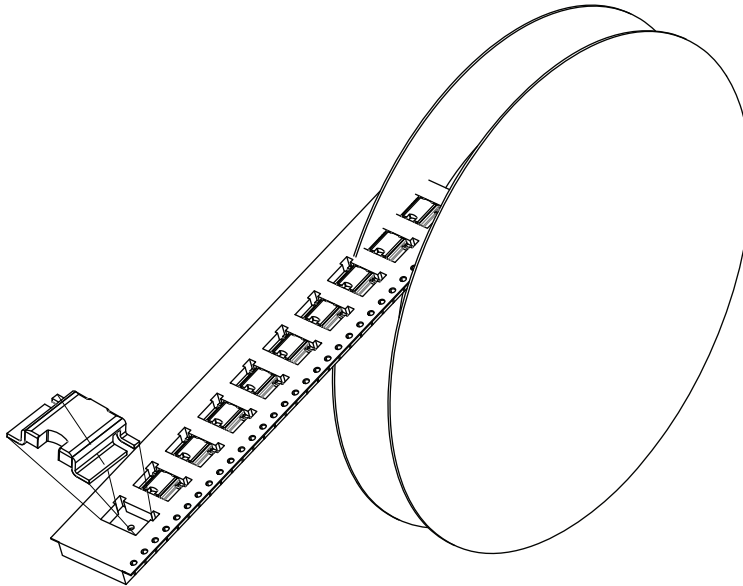



Disclaimer

ALL PRODUCT, PRODUCT SPECIFICATIONS AND DATA ARE SUBJECT TO CHANGE WITHOUT NOTICE TO IMPROVE RELIABILITY, FUNCTION OR DESIGN OR OTHERWISE.

Vishay Intertechnology, Inc., its affiliates, agents, and employees, and all persons acting on its or their behalf (collectively, "Vishay"), disclaim any and all liability for any errors, inaccuracies or incompleteness contained in any datasheet or in any other disclosure relating to any product.

Vishay makes no warranty, representation or guarantee regarding the suitability of the products for any particular purpose or the continuing production of any product. To the maximum extent permitted by applicable law, Vishay disclaims (i) any and all liability arising out of the application or use of any product, (ii) any and all liability, including without limitation special, consequential or incidental damages, and (iii) any and all implied warranties, including warranties of fitness for particular purpose, non-infringement and merchantability.

Statements regarding the suitability of products for certain types of applications are based on Vishay's knowledge of typical requirements that are often placed on Vishay products in generic applications. Such statements are not binding statements about the suitability of products for a particular application. It is the customer's responsibility to validate that a particular product with the properties described in the product specification is suitable for use in a particular application. Parameters provided in datasheets and / or specifications may vary in different applications and performance may vary over time. All operating parameters, including typical parameters, must be validated for each customer application by the customer's technical experts. Product specifications do not expand or otherwise modify Vishay's terms and conditions of purchase, including but not limited to the warranty expressed therein.

Except as expressly indicated in writing, Vishay products are not designed for use in medical, life-saving, or life-sustaining applications or for any other application in which the failure of the Vishay product could result in personal injury or death. Customers using or selling Vishay products not expressly indicated for use in such applications do so at their own risk. Please contact authorized Vishay personnel to obtain written terms and conditions regarding products designed for such applications.

No license, express or implied, by estoppel or otherwise, to any intellectual property rights is granted by this document or by any conduct of Vishay. Product names and markings noted herein may be trademarks of their respective owners.