

## Analog Displacement Sensors for Transportation Applications



### FEATURES

- Conductive plastic potentiometer technology
- Use in engine compartment
- Hollow shaft coupling
- Wire outputs
- Device eliminating shaft alignment faults
- Material categorization: for definitions of compliance please see [www.vishay.com/doc?99912](http://www.vishay.com/doc?99912)



**RoHS**  
COMPLIANT

### QUICK REFERENCE DATA

Sensor type	ROTATIONAL, conductive plastic
Output type	Output by wires
Market appliance	Transportation
Dimensions	42 mm x 31.5 mm x 23.37 mm

### ELECTRICAL SPECIFICATIONS

PARAMETER	
Total electrical travel	94° ± 2°
Independent linearity standard	± 1.5 %
Total resistance (R <sub>n</sub> )	3.85 kΩ ± 20 %
Output smoothness	< 0.1 % (NFC 93255)
Power rating at +40 °C	0.5 W
Power rating at +125 °C	0.05 W
Wiper current limiting resistance (R <sub>p</sub> )	1.7 kΩ ± 20 %
Recommended wiper current	≤ 100 μA
Maximum wiper current	15 mA for 1 min
Recommended load impedance	≥ 100 R <sub>n</sub>

### MECHANICAL SPECIFICATIONS

PARAMETER	
Mechanical travel	128° ± 4°
Running torque	< 5 Ncm
Stop strength	30 Ncm
Maximum shaft alignment fault: hollow shaft Ø 8 - L = 9.5 mm. 6 mm on flat	0.2 mm
Protection class	IP 64 for 425 type sensor
	IP 66 for 427 type sensor
Mounting screw tightening torque	2.3 Nm maximum

### PERFORMANCE

PARAMETER	
Operating temperature range	-40 °C to +125 °C
Storage temperature range	-55 °C to +135 °C
Vibrations: use in engine compartment	Severity 10 Hz to 2000 Hz, 10 mm or 50 g
Life (on TET)	5M cycles
Micro-movements (dither stroke)	50M cycles

#### Note

- Nothing stated herein shall be construed as a guarantee of quality or durability.



SAP PART NUMBERING GUIDELINES - PMR427						
MODEL	TYPE	LEVER TYPE	VALUE	ANGLE	LEADS	PACKAGING
PMR4	27 = hollow shaft	H = hollow shaft	392 = 3K9	094	W = wire (for PMR420)	C = 20 pcs G = 100 pcs P = 500 pcs

CONNECTIONS
<b>Wire Outputs:</b> -40 °C to +105 °C (3 x 0.93 mm <sup>2</sup> , length 300 mm) <b>Sheathed Wire Outputs:</b> -40 °C to +125 °C optional

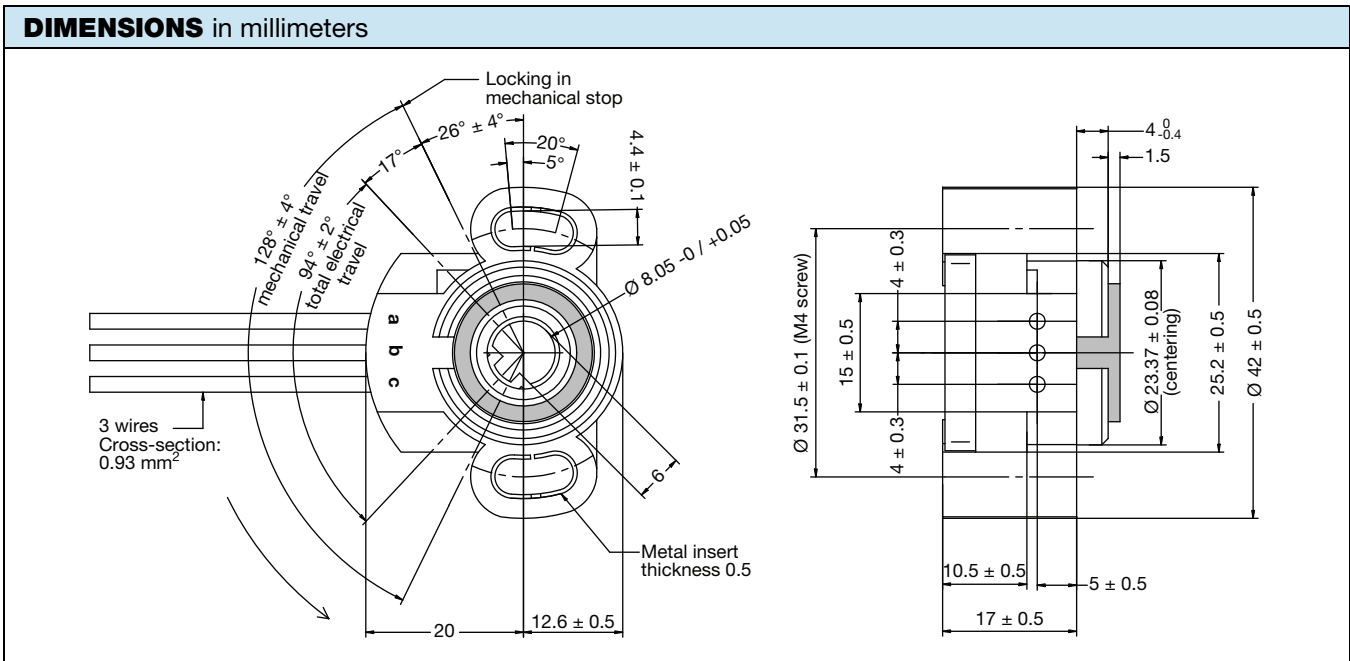

**ELECTRICAL DIAGRAM**

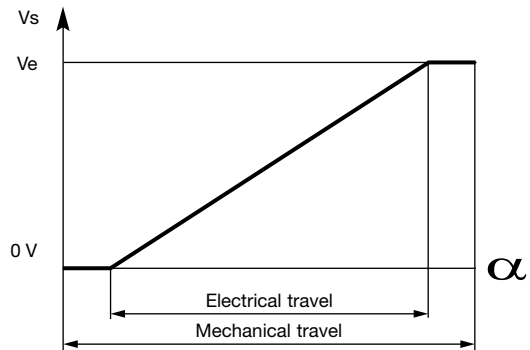
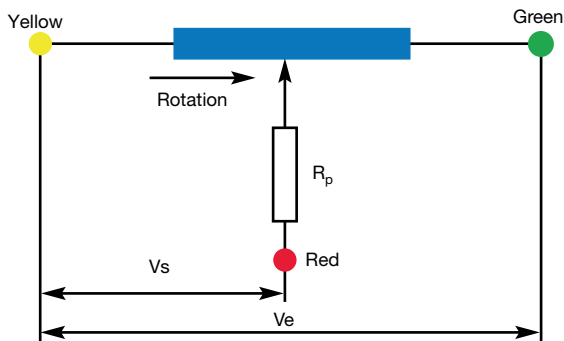

**OPTIONS** (on request)

- Other total electrical travel
- Other total resistance
- Other linearity
- No protection resistance (R<sub>p</sub>)
- High temperature sheathed wire outputs
- Specific connections



## Disclaimer

ALL PRODUCT, PRODUCT SPECIFICATIONS AND DATA ARE SUBJECT TO CHANGE WITHOUT NOTICE TO IMPROVE RELIABILITY, FUNCTION OR DESIGN OR OTHERWISE.

Vishay Intertechnology, Inc., its affiliates, agents, and employees, and all persons acting on its or their behalf (collectively, "Vishay"), disclaim any and all liability for any errors, inaccuracies or incompleteness contained in any datasheet or in any other disclosure relating to any product.

Vishay makes no warranty, representation or guarantee regarding the suitability of the products for any particular purpose or the continuing production of any product. To the maximum extent permitted by applicable law, Vishay disclaims (i) any and all liability arising out of the application or use of any product, (ii) any and all liability, including without limitation special, consequential or incidental damages, and (iii) any and all implied warranties, including warranties of fitness for particular purpose, non-infringement and merchantability.

Statements regarding the suitability of products for certain types of applications are based on Vishay's knowledge of typical requirements that are often placed on Vishay products in generic applications. Such statements are not binding statements about the suitability of products for a particular application. It is the customer's responsibility to validate that a particular product with the properties described in the product specification is suitable for use in a particular application. Parameters provided in datasheets and / or specifications may vary in different applications and performance may vary over time. All operating parameters, including typical parameters, must be validated for each customer application by the customer's technical experts. Product specifications do not expand or otherwise modify Vishay's terms and conditions of purchase, including but not limited to the warranty expressed therein.

Hyperlinks included in this datasheet may direct users to third-party websites. These links are provided as a convenience and for informational purposes only. Inclusion of these hyperlinks does not constitute an endorsement or an approval by Vishay of any of the products, services or opinions of the corporation, organization or individual associated with the third-party website. Vishay disclaims any and all liability and bears no responsibility for the accuracy, legality or content of the third-party website or for that of subsequent links.

Except as expressly indicated in writing, Vishay products are not designed for use in medical, life-saving, or life-sustaining applications or for any other application in which the failure of the Vishay product could result in personal injury or death. Customers using or selling Vishay products not expressly indicated for use in such applications do so at their own risk. Please contact authorized Vishay personnel to obtain written terms and conditions regarding products designed for such applications.

No license, express or implied, by estoppel or otherwise, to any intellectual property rights is granted by this document or by any conduct of Vishay. Product names and markings noted herein may be trademarks of their respective owners.