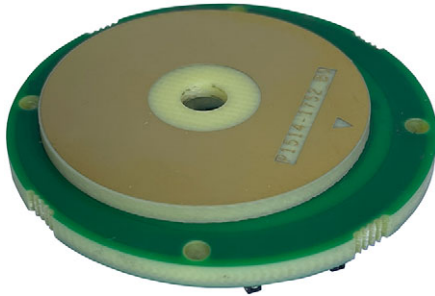

## Rotational Absolute Inductive Kit Encoder Version 45 mm Medium Precision Position Sensor

**RoHS  
COMPLIANT**

### FEATURES

- Off-axis rotational absolute inductive encoder
- Especially dedicated to motor drive, to robot's position and industrial motion control with accurate positioning
- Rotation speed up to 10 000 rpm
- High repeatability, high precision, high resolution, single turn
- Not sensitive to external magnetic fields (no Hall effect cells), electrical fields and temperature
- Not sensitive to moisture and pollution
- Especially dedicated for harsh conditions (vibrations, shocks, EMC...)
- Material categorization: for definitions of compliance please see [www.vishay.com/doc?99912](http://www.vishay.com/doc?99912)

### LINKS TO ADDITIONAL RESOURCES



3D Models



Infographics



Did You Know?

QUICK REFERENCE DATA	
Sensor type	ROTATIONAL, inductive technology
Output type	Connector Molex 5037630691 or pads
Market appliance	Industrial
Dimensions	Diameter 45 mm

ELECTRICAL SPECIFICATIONS	
PARAMETER	RAIK045I11318
Voltage power supply (on sensor connector)	5 V <sub>DC</sub> ± 0.5 V <sub>DC</sub>
Supply current at 5 V <sub>DC</sub>	≤ 12 mA
Output format	SPI, Sin Cos (on request, consult us about performances)
Useful electrical angle	360°
Accuracy at 25 °C	≥ 10 bits (0.35°) (typical value: 0.22°)
Typical derating over the temperature range (-40 °C to +105 °C)	± 0.16°
Repeatability	≥ 14 bits
Hysteresis	No hysteresis
Output noise (at 25 °C with airgap 0.4 mm)	< ± 6 LSB peak (typical: < ± 3 LSB)
Resolution	65 536 points (16 bits, ≈ 0.0055°)
Startup time	≤ 3 ms
Data latency time	Typ. 200 μs
Refresh rate	4.6 kHz
Maximum sample rate	≤ 30 kHz (at clock 1.4 MHz)

MECHANICAL SPECIFICATIONS	
PARAMETER	
Mechanical angle	360°
Maximum rotation speed	10 000 rpm (more on request)
Rotor weight	≤ 4.3 g
Stator weight	< 9.0 g

SAP PART NUMBERING GUIDELINES										
TYPE	MODEL	DESIGN	SIZE (mm)	TYPE	FUNCTION	ACCURACY (BITS)	RESOLUTION (BITS)	OUTPUT	PACKAGING	OPTION
R = rotational	AI	K = kit	045	I = industrial	1	10	16	F = SPI CCW	B = box	xxx = customized design
							UU	N = Sin Cos <sup>(1)</sup>		

**Notes**

- Connection by pads on request
- Analog output on request
- <sup>(1)</sup> On request

ACCESSORY	
External connector equipped with wires to obtain a wires output (see section "Accessories on Request")	ACCSRAIKWIRESOB073

PERFORMANCE	
PARAMETER	
Standard operating temperature range	-40 °C to +125 °C
Storage temperature range	-55 °C to +125 °C <sup>(1)</sup>
Environmental protection	Coating on PCB components side (on request)

**Note**

- <sup>(1)</sup> 125 °C for the pads variant; 105 °C for the connector variant

EMC PARAMETERS		
PARAMETER	STANDARD	LEVEL
Electrostatic discharge immunity (ESD)	61000-4-2 :2008	Level 1 (2 kV) - contact discharge (contact discharge valid only on the connector interface)

**Notes**

- Levels compliant with EN IEC 61326-1, industrial
- The sensor does not integrate protection against surges caused by overvoltages from switching and lightning transients (61000-4-5). It is recommended to use external protection if this standard is to be applied. To minimize the risk, we recommend that the power supply cable does not exceed 3 meters, and the data line does not exceed 30 meters

**OTHER INFORMATION**

**ATTENTION!**

Observe Precautions for Handling Electrostatic Sensitive Devices!



**Warning: the rotor and the stator must have the same serial number!**

- The sensor is delivered in an ESD packaging. To ensure safe handling, remove the sensor from its ESD bag only in an Electrostatic Protected Area (EPA)
- Do not damage the rotor disk surface
- Do not use cleaning product or chemical product
- Environmental protection: conformal coating or potting on request for use in heavy-duty environments (metallic particles, oils, greases, salt spray, moisture, corrosion...)



**SENSOR DIMENSIONS**

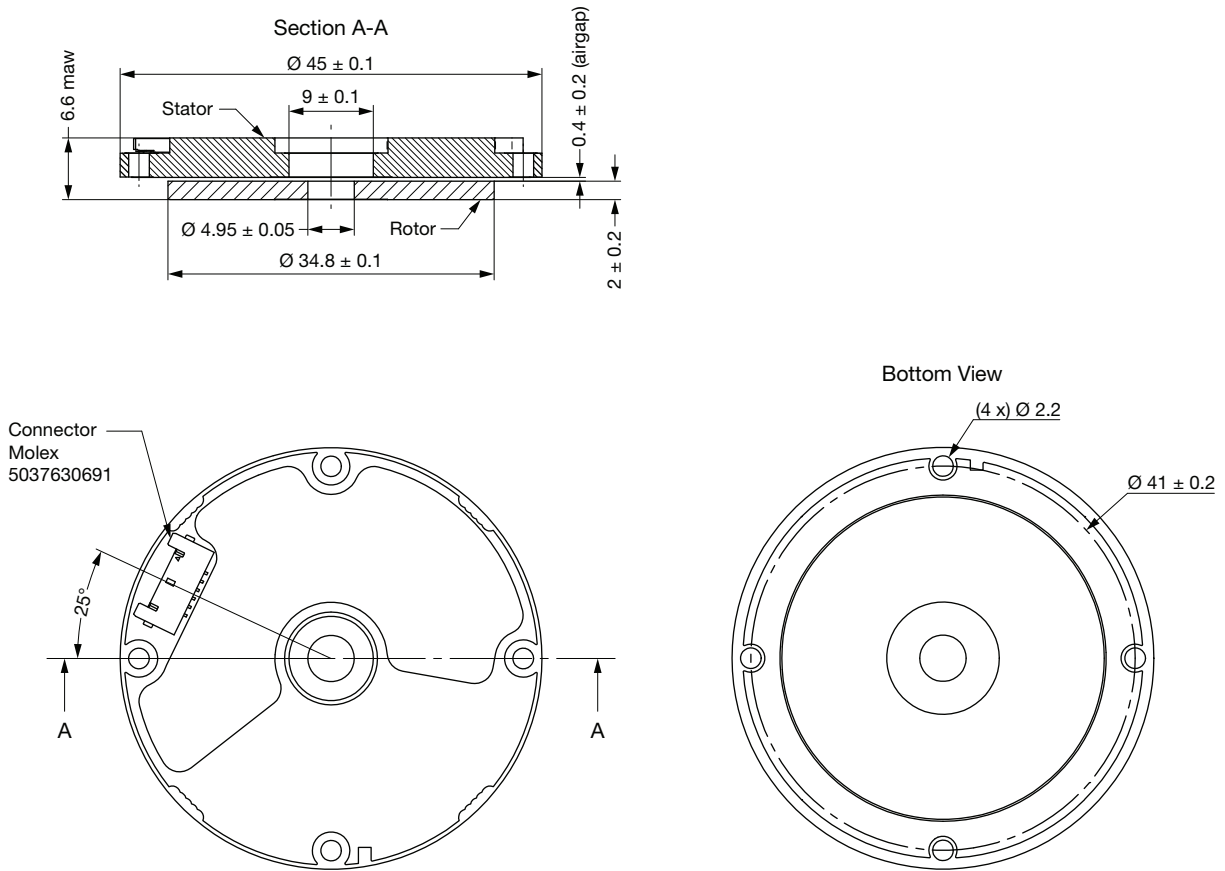

**MOUNTING CONDITIONS**

**GENERAL**

- Observe precautions for handling electrostatic sensitive devices
- Rotor mounting: the positioning of the rotor should be referenced to its internal diameter with respecting the tolerances given in the hereafter tab: diameter 5 g6
- Stator mounting: it is strongly recommended to center the position of the stator by the internal diameter as described in §1 with using a cone centering tool. If not possible, to center the stator by the external diameter with respecting the tolerances given in the hereafter tab: diameter 45 H7
- It is recommended to apply threadlocker to the screw depending on environmental and usage conditions



**1. RECOMMENDED EASIER ASSEMBLING**

With using a cone centering tool.

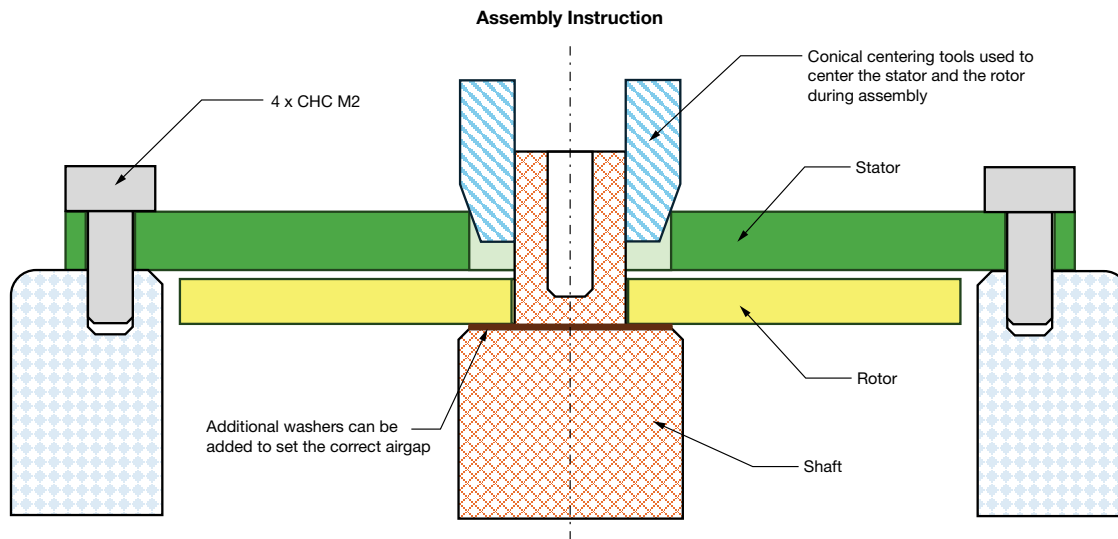

**Note**

- During assembly, do not fully tighten the fastening screws to allow the stator to move and align with the shaft using the centering tool. The final tightening should be carried out while holding the tool in place

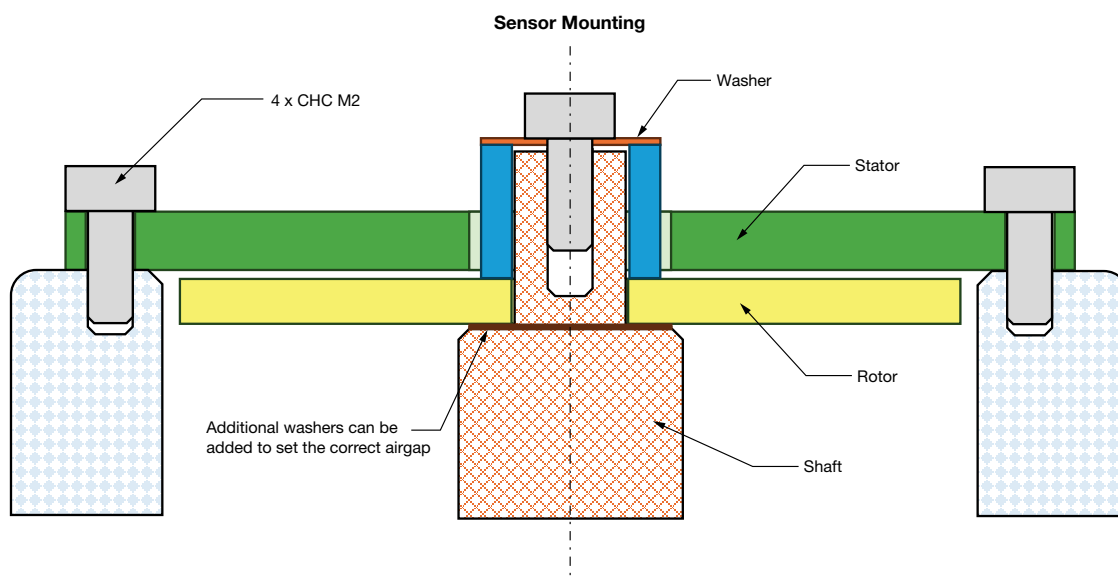

Fastening: M2 according to ISO 4762 (stainless steel A4 with recommended torque = 0.2 Nm ± 10 %

**2. ALTERNATIVE ASSEMBLING (if the customer cannot use a cone centering tool)**

To center the stator by the external diameter with respecting the tolerances given in the hereafter tab: diameter 45 H7.

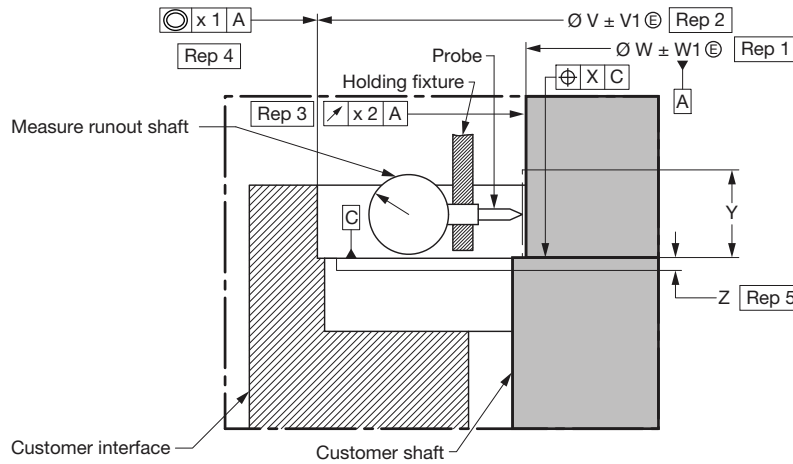
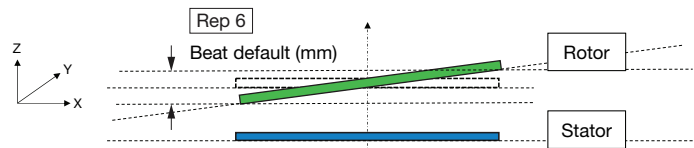

Fig. 1 - Mounting Detail



Rotor axis and stator axis are the same but the reference surfaces are not parallel

Fig. 2 - Beat

RECOMMENDED DIMENSIONS AND TOLERANCES OF CUSTOMER INTERFACES		
<b>Rep 1</b>	Customer shaft diameter for centering of the rotor (see Fig. 1)	Diameter $\varnothing$ 5 g6 (5 mm - 0.004 mm - 0.012 mm)
<b>Rep 2</b>	Customer interface diameter for centering of the stator (see Fig. 1)	Diameter $\varnothing$ 45 H7 (45 mm + 0.025 mm - 0.000 mm)
<b>Rep 3</b>	Diameter runout of the customer shaft for the rotor centering (included gap between customer shaft and inner rotor diameter) (see Fig. 1)	< 0.120 mm
<b>Rep 4</b>	Misalignment: concentricity of the stator centering diameter versus shaft centering diameter (included tolerances of customer holder and stator interface) (see Fig. 1)	< 0.150 mm
<b>Rep 5</b>	Position of the stator reference upper surface versus rotor reference bottom surface (see Fig. 1) (air-gap: the condition of previous line avoids to measure the air-gap)	0.4 mm $\pm$ 0.15 mm
<b>Rep 6</b>	Total beat included in the air-gap between ref. C (rotor) and ref. D (stator) (see Fig. 2)	< 0.2 mm

**Note**

- Values at room temperature

**COMMUNICATION INTERFACES**

SPI protocol

 Power supply signal ( $V_{CC}$ , GND) does not need to be twisted pair.

The SPI (Serial Peripheral Interface) is a four-wire bidirectional synchronous serial communications interface used for short-distance communications ( $\leq 30$  cm). This protocol is full duplex (communication in both directions simultaneously) and signals are 3.3 V LVTTTL (5 V tolerant). The master controller selects the slave with the  $\overline{CS}$  line, generates a clock signal on the SCLK line, sends commands on the MOSI line and receives data on the MISO line.

**CONNECTOR TYPES:**

Output connector mounted on the RAIK045: Molex 5037630691

Customer connector equipped of wires gauge 28 to plug:

- Female connector Molex 503764-0601
- Contacts Molex 503765-0098

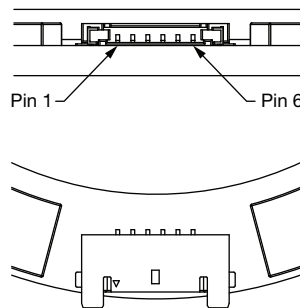
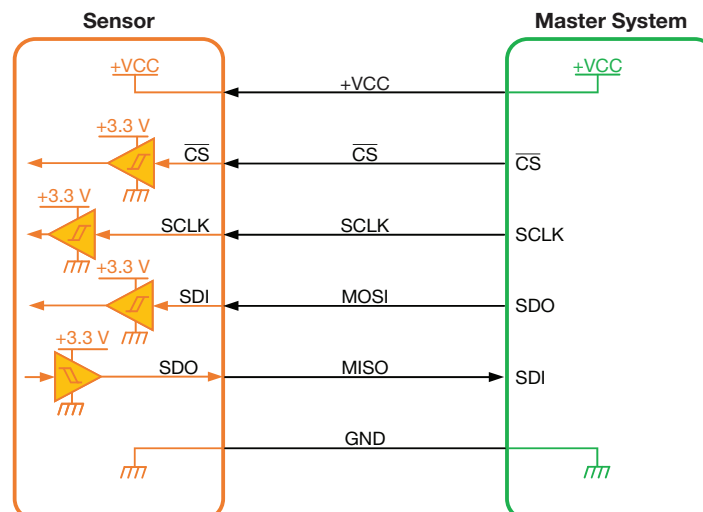

Fig. 3

SPI PINOUT				
PIN NO.	NAME	DESCRIPTION	TYPE	OPTIONAL: WIRE EQUIPPED CONNECTOR (P/N: ACCSRAIKWIRESOB073)
1	VCC	Power supply input	Power	Red
2	SCLK	SPI clock input	Input	Orange
3	$\overline{CS}$	SPI chip select input (active low)	Input	Yellow
4	MOSI	SPI data input (from master to slave)	Input	White
5	MISO	SPI data output (from slave to master)	Output	Green
6	GND	Ground	Power	Black

**Note**

- See section “Accessories on Request” for details on the wire equipped connector

**COMMUNICATION DIAGRAM**

**SPI OUTPUT FORMAT**
**SPI Frame**

Fig. 4

SPI PARAMETERS	
PARAMETER	INFORMATION
SPI compatible configuration	Direct connection (no daisy chain), single master, multiple slaves
SPI interface	3.3 V LVTTTL (inputs are 5 V tolerant)
SPI mode	Mode 0 (CPOL0, CPHA0) The output shift register is clocked on the rising edge of SPI_CLK
Inactive time ( $t_{inact}$ )	$\geq 500$ ns
Processing time ( $t_{fcd}$ )	$\geq 400$ ns (CS falling edge to CLK first rising edge)
Clock frequency ( $f_{clk} = 1/t_{clk}$ )	$100$ kHz $\leq f_{clock} \leq 1.4$ MHz
Propagation delay ( $t_{MISO\_delay}$ )	214 ns
Total number of bit (simple frame)	32
Data angle [15 : 0]	16 bits, binary code, MSB first (0 to 65 535)
Counter [3 : 0]	Incremental counter per each correctly received SPI frame
Status [3 : 0]	Bits 0 and 1: value = 0 Bit 2: position error Bit 3: SPI error
Simple frame error detection [7 : 0]	CRC, 8 bits polynomial $0x107 (X^8 + X^2 + X^1 + X^0)$ CRC start value "0xFF"

SPI COMMANDS			
R/W	CODE (HEX)	COMMAND	DETAILS
R	0x000000D1	Read angle	Data angle can be read on the next SPI frame

**ACCESSORIES ON REQUEST**

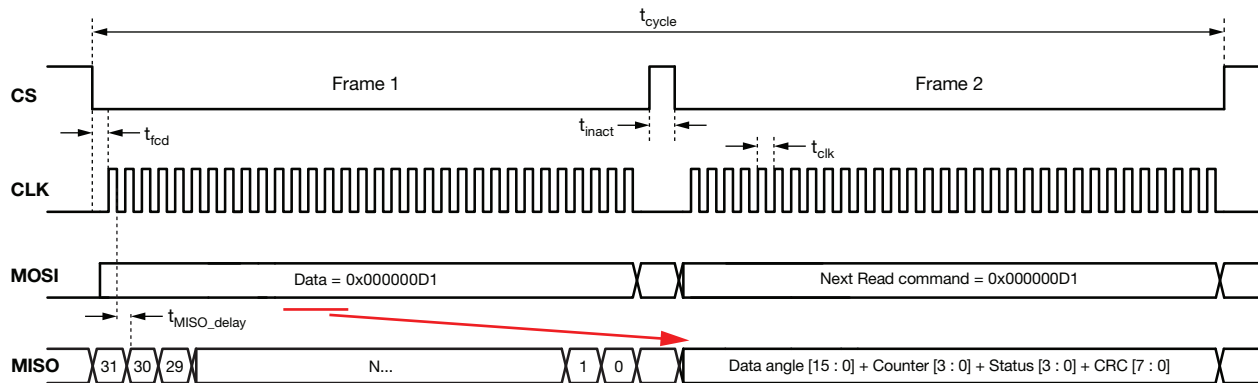
**EXTERNAL CONNECTOR EQUIPPED OF WIRES TO OBTAIN A WIRES OUTPUT (ACCSRAIKWIRESOB073)**

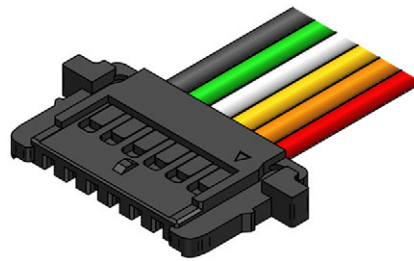
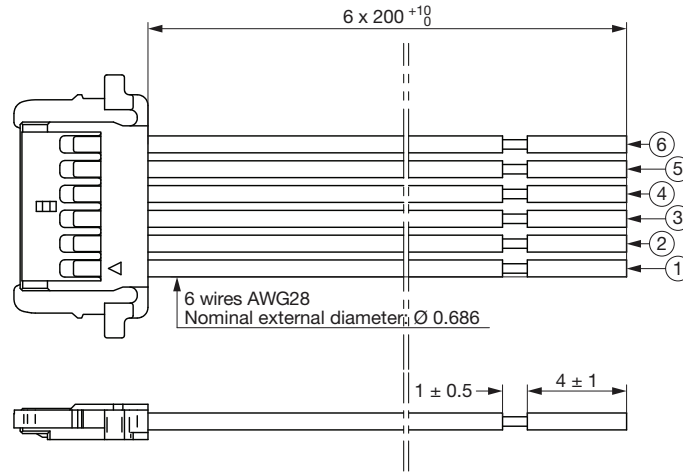

**Note**

- General tolerancing according to ISO 8015



## **Disclaimer**

ALL PRODUCT, PRODUCT SPECIFICATIONS AND DATA ARE SUBJECT TO CHANGE WITHOUT NOTICE TO IMPROVE RELIABILITY, FUNCTION OR DESIGN OR OTHERWISE.

Vishay Intertechnology, Inc., its affiliates, agents, and employees, and all persons acting on its or their behalf (collectively, "Vishay"), disclaim any and all liability for any errors, inaccuracies or incompleteness contained in any datasheet or in any other disclosure relating to any product.

Vishay makes no warranty, representation or guarantee regarding the suitability of the products for any particular purpose or the continuing production of any product. To the maximum extent permitted by applicable law, Vishay disclaims (i) any and all liability arising out of the application or use of any product, (ii) any and all liability, including without limitation special, consequential or incidental damages, and (iii) any and all implied warranties, including warranties of fitness for particular purpose, non-infringement and merchantability.

Statements regarding the suitability of products for certain types of applications are based on Vishay's knowledge of typical requirements that are often placed on Vishay products in generic applications. Such statements are not binding statements about the suitability of products for a particular application. It is the customer's responsibility to validate that a particular product with the properties described in the product specification is suitable for use in a particular application. Parameters provided in datasheets and / or specifications may vary in different applications and performance may vary over time. All operating parameters, including typical parameters, must be validated for each customer application by the customer's technical experts. Product specifications do not expand or otherwise modify Vishay's terms and conditions of purchase, including but not limited to the warranty expressed therein.

Hyperlinks included in this datasheet may direct users to third-party websites. These links are provided as a convenience and for informational purposes only. Inclusion of these hyperlinks does not constitute an endorsement or an approval by Vishay of any of the products, services or opinions of the corporation, organization or individual associated with the third-party website. Vishay disclaims any and all liability and bears no responsibility for the accuracy, legality or content of the third-party website or for that of subsequent links.

Vishay products are not designed for use in life-saving or life-sustaining applications or any application in which the failure of the Vishay product could result in personal injury or death unless specifically qualified in writing by Vishay. Customers using or selling Vishay products not expressly indicated for use in such applications do so at their own risk. Please contact authorized Vishay personnel to obtain written terms and conditions regarding products designed for such applications.

No license, express or implied, by estoppel or otherwise, to any intellectual property rights is granted by this document or by any conduct of Vishay. Product names and markings noted herein may be trademarks of their respective owners.