

Power Resistors Wire Thick Film Technology



FEATURES

- AEC-Q200 qualified (pending)
- Technology: thick film deposited on ceramic
- Cooled by auxiliary heatsink (not supplied)
- Cold system without external radiation
- High power 650 W at 85 °C bottom case temperature
- Non-inductive
- Low profile
- Easy assembly, self-calibrated pressure
- Internal temperature monitoring with a NTC thermistor
- Material categorization: for definitions of compliance please see www.vishay.com/doc?99912

RoHS
COMPLIANT

APPLICATIONS

- Precharge, discharge, and active discharge
- Power conversion and snubber

STANDARD ELECTRICAL SPECIFICATIONS

MODEL	RESISTANCE RANGE Ω	MAX. RATED POWER $BC_{85}^{\circ C}$ W	TOLERANCE ⁽¹⁾ \pm %	TEMPERATURE COEFFICIENT \pm ppm/°C	E-SERIES OHMIC VALUES
RPWA	6.2 to 1M	650	5, 10	150	E24

Note

- ⁽¹⁾ ± 2 % or ± 1 % on special request for limited resistance value and with reduction of maximum power and pulse rating (contact us for details)

MECHANICAL SPECIFICATIONS

UL 94 flame classifications	Material complies with the standard UL 94 V-0
Resistive element	Cermet
Substrate	Alumina
Encapsulation	Resin filled case
Cables	Cable type: FHL2G 0.5 mm ² (NTC) / 1.5 mm ² (power)

Note

- Custom cable lengths, terminal type, and termination available upon request: please contact us for configuration options

TECHNICAL SPECIFICATIONS

PARAMETER	RPWA 650
Operating temperature range resistor body	-55 °C to +155 °C
Nominal power at 85 °C bottom case temperature	650 W
Maximum operating voltage	1500 V _{DC} (1000 V _{AC}) (up to 6000 V _{DC} on request)
Dielectric strength V _{RMS} (50 Hz / 1 min)	4000 V (up to 7000 V on request)
Dielectric strength power resistor to NTC resistor	1500 V _{RMS} (50 Hz / 1 min)
Self-inductance (frequency 10 kHz)	≤ 40 nH, typical without cables (consult us for your specific cable length, e. g. < 0.7 μ H with two standard cables of 250 mm)
Insulation	≥ 10 G Ω at 1000 V _{DC}
Weight (max.)	80 g
NTC characteristics (option)	Vishay NTCS0603E3103FLT Vishay NTC is AEC-Q200 qualified Temperature cycling test -55 °C / +150 °C See "Resistance Value vs. Temperature" chart



PERFORMANCES (AEC-Q200 qualification pending)		
TESTS	CONDITIONS	REQUIREMENTS
High temperature exposure	MIL-STD-202 method 108 - 1000 h at T = 155 °C. Unpowered.	≤ ± (2 % + 0.1 Ω)
Temperature cycling	JESD22 method JA-104 - 1000 cycles (-40 °C to +125 °C)	≤ ± (2 % + 0.1 Ω)
Biased humidity	MIL-STD-202 method 103 / test cab of IEC 60068-2-78 - 1000 h 85 °C / 85 % RH, Powered to 1 W. (exception: 1 MΩ will be tested unpowered)	≤ ± (5 % + 0.1 Ω)
Operational life	MIL-STD-202 method 108 condition D Steady state T _A = 85 °C of bottom case at rated power 650 W 90' on / 30' off / 1000 h	≤ ± (5 % + 0.1 Ω)
Terminal strength (lead)	MIL-STD-202 method 211 - test leaded device lead integrity only Conditions: A (2.27 kg cables 0.5 mm ² , 4 kg cables 1.5 mm ²)	≤ ± (0.5 % + 0.1 Ω)
Mechanical shock	MIL-STD-202 method 213 /IEC 60068-2-29 test Eb: /Ea of IEC 60068-2-27	≤ ± (0.5 % + 0.1 Ω)
Vibration	MIL-STD-202 method 204 /Fc of IEC 60068-2-6	≤ ± (0.5 % + 0.1 Ω)
ESD	AEC-Q200-002 - 6 kV to 25 kV	≤ ± (0.5 % + 0.1 Ω)

Note

- All tests were done in Vishay MCB laboratory conditions

DISSIPATION

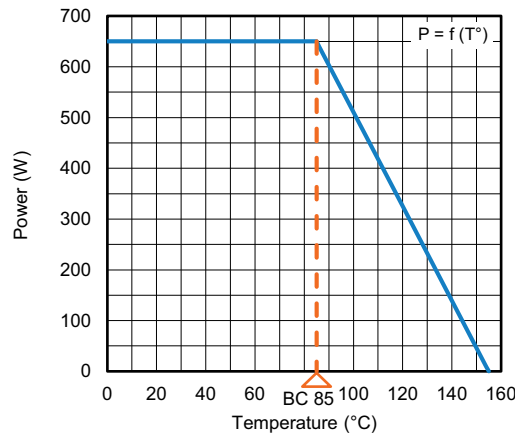

Permanent Applicable Power (W) as a Function of Bottom Case Temperature (°C)

ENERGY

Repetitive operation: 3.5 J / pulse t = 50 μs

Other t values: contact us

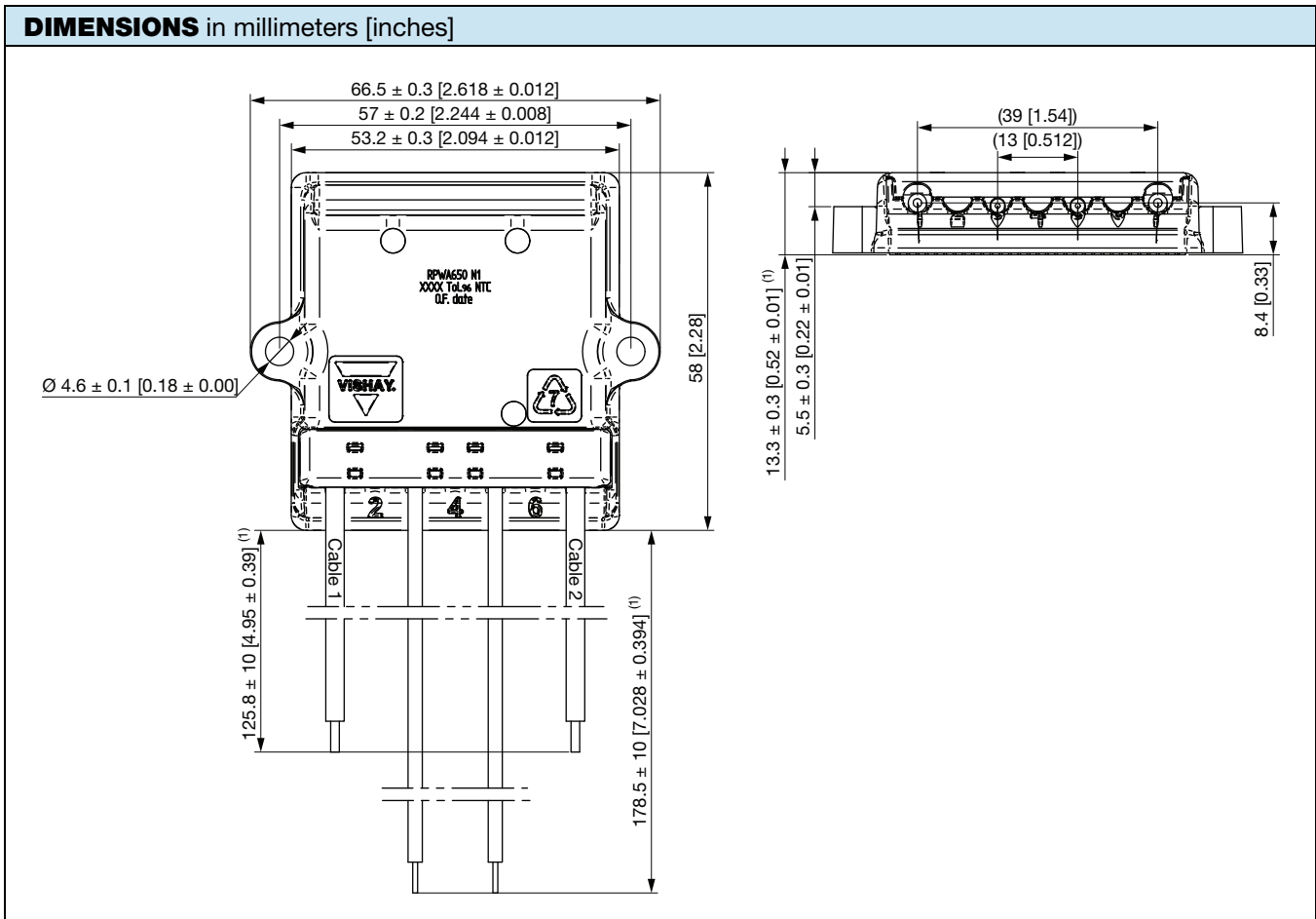

Note

⁽¹⁾ Under alumina

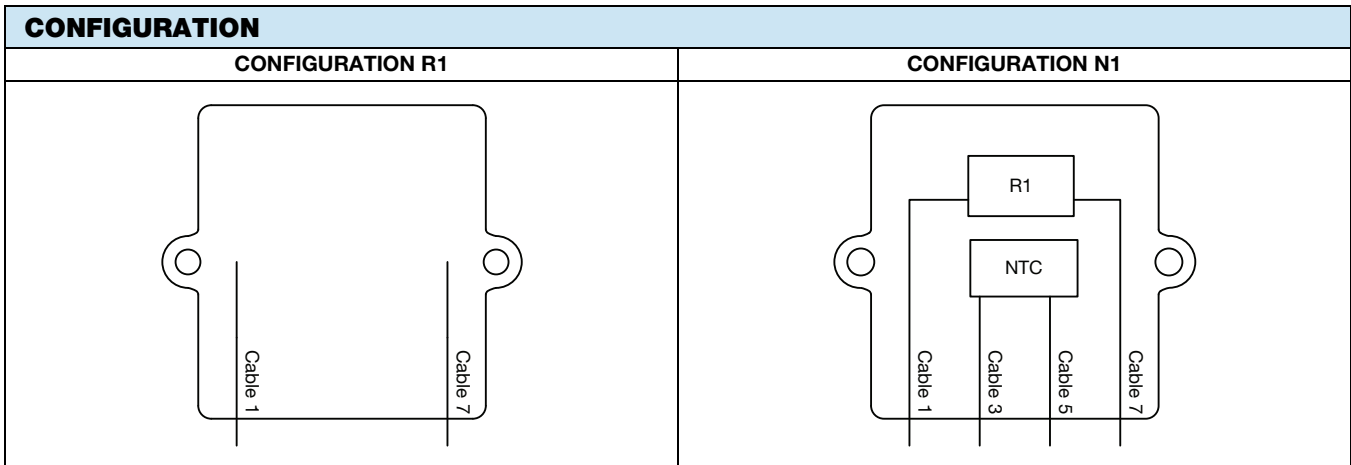

OPTIONS

- Other configuration upon request
- Thermal sensor

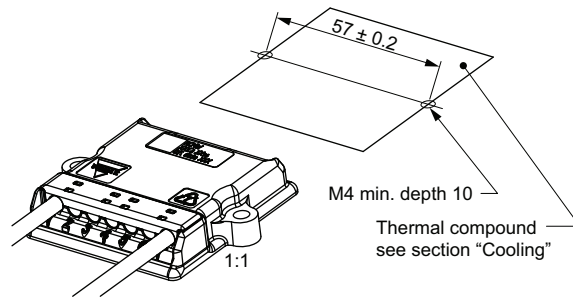
ASSEMBLY

 Tightening torque for mechanical mounting:
 $1.8 \text{ Nm} \pm 0.2 \text{ Nm}$
COOLING

The temperature of the heatsink may be maintained at the specified values with:

- Forced air ventilation or internal circulation of a liquid cooling
- Heatsink contact surface: $< \text{Ra } 6.3 \mu$
- Evenness defect: 0.05 mm max.
- Surface temperature gradient (isotherm): 20 °C max.
- Thermal compound not supplied (resistance $< 0.025 \text{ }^\circ\text{C/W} / 0.05 \text{ mm}$ preconized)
- Mounting recommendation: www.vishay.com/doc?32586

The user must select the thermal resistance of the heatsink according to the power applied

ORDERING INFORMATION						
RPWA	650	N1	XXXX	5 %	XXX	BO10
MODEL	STYLE	CONFIGURATION	RESISTANCE VALUE	TOLERANCE	CUSTOM DESIGN (optional on request)	PACKAGING
		Single resistor or resistor and NTC				

GLOBAL PART NUMBER INFORMATION																	
R	P	W	A	6	5	0	N	1	1	8	0	2	J	B	X	X	X
1							2		3			4	5	6			
1		2		3		4		5		6							
GLOBAL MODEL		CONFIGURATION		OHMIC VALUE		TOLERANCE		PACKAGING		INDUSTRIALIZATION NUMBER							
RPWA 650		R1: resistor only N1: resistor and NTC		The first three digits are significant figures and the last specifies the number of zeros to follow, R designates decimal point. 1802 = 18 kΩ		J = 5 % K = 10 %		B = box		3 specific digits (if applicable)							

EXAMPLE		
MODEL	DESCRIPTION	PART NUMBER
RPWA 650	RPWA 650 N1 6U20 5 % xxx BOxx	RPWA650N16R20JBxxx



Disclaimer

ALL PRODUCT, PRODUCT SPECIFICATIONS AND DATA ARE SUBJECT TO CHANGE WITHOUT NOTICE TO IMPROVE RELIABILITY, FUNCTION OR DESIGN OR OTHERWISE.

Vishay Intertechnology, Inc., its affiliates, agents, and employees, and all persons acting on its or their behalf (collectively, "Vishay"), disclaim any and all liability for any errors, inaccuracies or incompleteness contained in any datasheet or in any other disclosure relating to any product.

Vishay makes no warranty, representation or guarantee regarding the suitability of the products for any particular purpose or the continuing production of any product. To the maximum extent permitted by applicable law, Vishay disclaims (i) any and all liability arising out of the application or use of any product, (ii) any and all liability, including without limitation special, consequential or incidental damages, and (iii) any and all implied warranties, including warranties of fitness for particular purpose, non-infringement and merchantability.

Statements regarding the suitability of products for certain types of applications are based on Vishay's knowledge of typical requirements that are often placed on Vishay products in generic applications. Such statements are not binding statements about the suitability of products for a particular application. It is the customer's responsibility to validate that a particular product with the properties described in the product specification is suitable for use in a particular application. Parameters provided in datasheets and / or specifications may vary in different applications and performance may vary over time. All operating parameters, including typical parameters, must be validated for each customer application by the customer's technical experts. Product specifications do not expand or otherwise modify Vishay's terms and conditions of purchase, including but not limited to the warranty expressed therein.

Hyperlinks included in this datasheet may direct users to third-party websites. These links are provided as a convenience and for informational purposes only. Inclusion of these hyperlinks does not constitute an endorsement or an approval by Vishay of any of the products, services or opinions of the corporation, organization or individual associated with the third-party website. Vishay disclaims any and all liability and bears no responsibility for the accuracy, legality or content of the third-party website or for that of subsequent links.

Vishay products are not designed for use in life-saving or life-sustaining applications or any application in which the failure of the Vishay product could result in personal injury or death unless specifically qualified in writing by Vishay. Customers using or selling Vishay products not expressly indicated for use in such applications do so at their own risk. Please contact authorized Vishay personnel to obtain written terms and conditions regarding products designed for such applications.

No license, express or implied, by estoppel or otherwise, to any intellectual property rights is granted by this document or by any conduct of Vishay. Product names and markings noted herein may be trademarks of their respective owners.