

Inductors / Transformers Customizable, Surface-Mount Torodial, Kool-Mu[®], Powdered Iron and MPP Cores

Note

- Kool Mu[®] is a registered trademark of Spang & Company

FEATURES

- Toroidal design for minimal EMI radiation in DC/DC converter applications
- Designed to support the growing need for efficient DC/DC converters in battery operated equipment
- Two separate windings provide versatility by ability to connect windings in series or parallel
- Dielectric withstanding voltage: 500 V_{RMS}, 60 Hz, 5 s
- Operating temperature range: -40 °C to +125 °C
- Supplied on tape and reel and is designed to be pick and place compatible
- Custom versions and turns ratios available. Contact the factory with your specifications
- Material categorization: for definitions of compliance please see www.vishay.com/doc?99912

**RoHS
COMPLIANT**
STANDARD ELECTRICAL SPECIFICATIONS (in parallel)

MODEL	STD. IND. (μH)	IND. TOL.	ACTUAL IND. (LOC) (μH)	DCR (Ω)	RATED I _{DC} (40 °C) (A)	IND. AT I _{DC} (L _{BIAS}) (30 %)	
LPT3535ER1R0LK	1.0	± 15 %	0.800	0.005	6.42	0.48 at 7.05	Kool Mu [®] CORE (A)
LPT3535ER1R5LK	1.5	± 15 %	1.80	0.009	4.77	1.07 at 4.70	
LPT3535ER2R5LK	2.5	± 15 %	2.45	0.011	4.45	1.46 at 4.03	
LPT3535ER3R3LK	3.3	± 15 %	3.20	0.015	3.73	1.90 at 3.52	
LPT3535ER5R0LK	5.0	± 15 %	5.00	0.023	3.01	2.98 at 2.82	
LPT3535ER100LK	10	± 15 %	11.3	0.055	1.95	6.69 at 1.88	
LPT3535ER150LK	15	± 15 %	16.2	0.081	1.59	9.64 at 1.57	
LPT3535ER250LK	25	± 15 %	26.5	0.131	1.25	15.7 at 1.23	
LPT3535ER330LK	33	± 15 %	33.8	0.182	1.05	20.1 at 1.08	
LPT3535ER500LK	50	± 15 %	51.2	0.280	0.84	30.5 at 0.88	
LPT3535ER101LK	100	± 15 %	101	0.514	0.63	60.2 at 0.63	
LPT3535ER151LK	150	± 15 %	151	0.775	0.57	90.0 at 0.51	
LPT3535ER251LK	250	± 15 %	252	1.279	0.40	150.0 at 0.40	
LPT3535ER331LK	330	± 15 %	328	1.837	0.33	195.0 at 0.35	
LPT3535ER1R0LP	1.0	± 15 %	0.882	0.004	5.10	0.56 at 4.29	
LPT3535ER1R5LP	1.5	± 15 %	1.57	0.005	4.48	0.99 at 3.21	
LPT3535ER2R5LP	2.5	± 15 %	2.45	0.009	3.58	1.54 at 2.57	
LPT3535ER3R3LP	3.3	± 15 %	3.53	0.013	2.96	2.22 at 2.14	
LPT3535ER5R0LP	5.0	± 15 %	4.80	0.018	2.41	3.03 at 1.84	
LPT3535ER100LP	10	± 15 %	10.8	0.043	1.58	6.81 at 1.22	
LPT3535ER150LP	15	± 15 %	15.3	0.064	1.29	9.65 at 1.03	
LPT3535ER250LP	25	± 15 %	25.1	0.103	1.03	15.8 at 0.80	
LPT3535ER330LP	33	± 15 %	33.5	0.147	0.85	21.1 at 0.70	
LPT3535ER500LP	50	± 15 %	51.8	0.230	0.68	32.7 at 0.56	
LPT3535ER101LP	100	± 15 %	104	0.424	0.51	65.2 at 0.40	
LPT3535ER151LP	150	± 15 %	153	0.645	0.41	96.3 at 0.33	
LPT3535ER251LP	250	± 15 %	250	1.031	0.33	157.0 at 0.25	
LPT3535ER331LP	330	± 15 %	330	1.463	0.27	208.0 at 0.22	
LPT3535ER1R0LM	1.0	± 15 %	0.800	0.005	6.45	0.52 at 7.05	MPP (C)
LPT3535ER1R5LM	1.5	± 15 %	1.80	0.009	4.80	1.16 at 4.70	
LPT3535ER2R5LM	2.5	± 15 %	2.45	0.011	4.46	1.58 at 4.03	
LPT3535ER3R3LM	3.3	± 15 %	3.20	0.015	3.73	2.06 at 3.52	
LPT3535ER5R0LM	5.0	± 15 %	5.00	0.023	3.02	3.22 at 2.82	
LPT3535ER100LM	10	± 15 %	11.3	0.055	1.94	7.25 at 1.88	
LPT3535ER150LM	15	± 15 %	16.2	0.081	1.59	10.43 at 1.57	
LPT3535ER250LM	25	± 15 %	26.5	0.131	1.26	17.0 at 1.23	
LPT3535ER330LM	33	± 15 %	33.8	0.182	1.05	21.8 at 1.08	
LPT3535ER500LM	50	± 15 %	51.2	0.280	0.84	33.0 at 0.88	
LPT3535ER101LM	100	± 15 %	101	0.514	0.64	97.4 at 0.51	
LPT3535ER151LM	150	± 15 %	151	0.775	0.52	65.2 at 0.63	
LPT3535ER251LM	250	± 15 %	252	1.279	0.40	162.0 at 0.51	
LPT3535ER331LM	330	± 15 %	328	1.837	0.33	211.0 at 0.35	

DESCRIPTION						
LPT	3535	100 μH	± 15 %	A	ER	e2
MODEL	SIZE	INDUCTANCE VALUE	INDUCTANCE TOLERANCE	CORE / HEIGHT K = Kool Mu [®] (A) P = Powdered Iron (B) M = MPP (C)	PACKAGE CODE ER = reel	JEDEC [®] LEAD (Pb)-FREE STANDARD

GLOBAL PART NUMBER													
L	P	T	3	5	3	5	E	R	1	0	1	L	K
PRODUCT FAMILY			SIZE		PACKAGE CODE		INDUCTANCE VALUE			TOL.	CORE		

Note

- Series is also available with SnPb terminations by using package code RH for tape and reel (in place of ER)

DIMENSIONS in inches [millimeters]

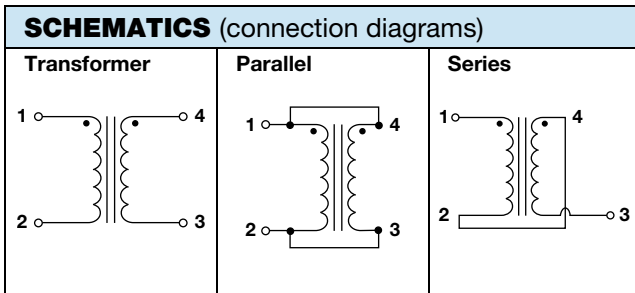
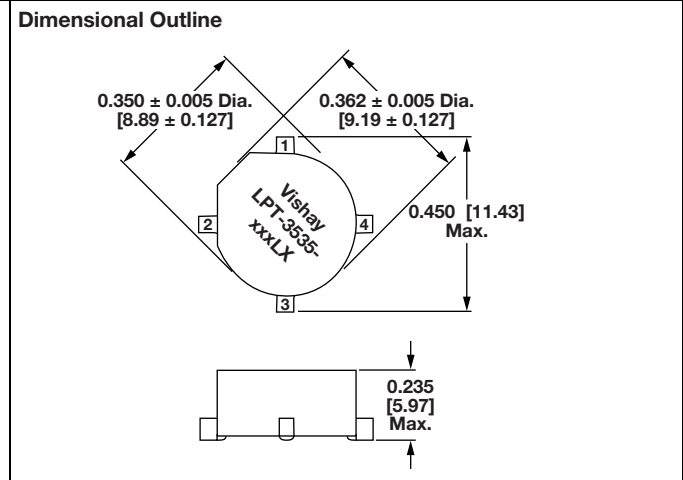
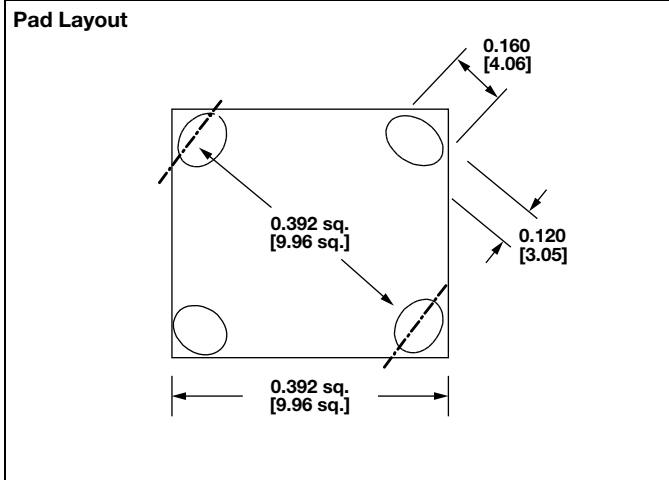

PART MARKING

- Vishay
- Model number
- Pin 1 identification

PACKAGING in inches [millimeters]

All embossed carrier tape packaging will be in compliance with the latest revision of EIA-481.	CARRIER TAPE WIDTH	PITCH	PARTS PER 13" [330.2] REEL
	0.945 [24.0]	0.630 [16.0]	600

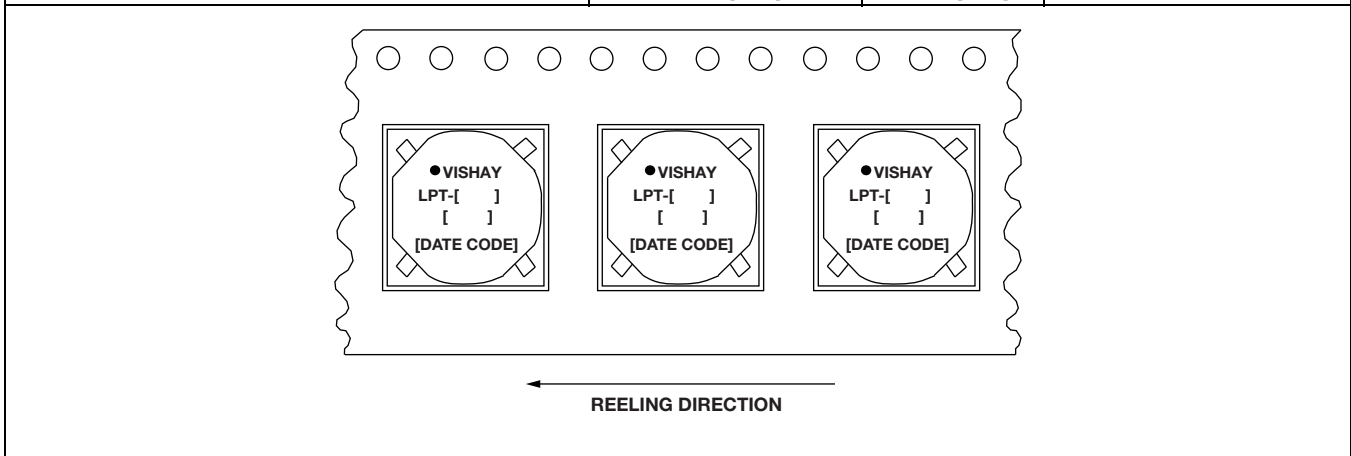



Disclaimer

ALL PRODUCT, PRODUCT SPECIFICATIONS AND DATA ARE SUBJECT TO CHANGE WITHOUT NOTICE TO IMPROVE RELIABILITY, FUNCTION OR DESIGN OR OTHERWISE.

Vishay Intertechnology, Inc., its affiliates, agents, and employees, and all persons acting on its or their behalf (collectively, "Vishay"), disclaim any and all liability for any errors, inaccuracies or incompleteness contained in any datasheet or in any other disclosure relating to any product.

Vishay makes no warranty, representation or guarantee regarding the suitability of the products for any particular purpose or the continuing production of any product. To the maximum extent permitted by applicable law, Vishay disclaims (i) any and all liability arising out of the application or use of any product, (ii) any and all liability, including without limitation special, consequential or incidental damages, and (iii) any and all implied warranties, including warranties of fitness for particular purpose, non-infringement and merchantability.

Statements regarding the suitability of products for certain types of applications are based on Vishay's knowledge of typical requirements that are often placed on Vishay products in generic applications. Such statements are not binding statements about the suitability of products for a particular application. It is the customer's responsibility to validate that a particular product with the properties described in the product specification is suitable for use in a particular application. Parameters provided in datasheets and / or specifications may vary in different applications and performance may vary over time. All operating parameters, including typical parameters, must be validated for each customer application by the customer's technical experts. Product specifications do not expand or otherwise modify Vishay's terms and conditions of purchase, including but not limited to the warranty expressed therein.

Hyperlinks included in this datasheet may direct users to third-party websites. These links are provided as a convenience and for informational purposes only. Inclusion of these hyperlinks does not constitute an endorsement or an approval by Vishay of any of the products, services or opinions of the corporation, organization or individual associated with the third-party website. Vishay disclaims any and all liability and bears no responsibility for the accuracy, legality or content of the third-party website or for that of subsequent links.

Vishay products are not designed for use in life-saving or life-sustaining applications or any application in which the failure of the Vishay product could result in personal injury or death unless specifically qualified in writing by Vishay. Customers using or selling Vishay products not expressly indicated for use in such applications do so at their own risk. Please contact authorized Vishay personnel to obtain written terms and conditions regarding products designed for such applications.

No license, express or implied, by estoppel or otherwise, to any intellectual property rights is granted by this document or by any conduct of Vishay. Product names and markings noted herein may be trademarks of their respective owners.