

Infrared Touch Panel with Controller

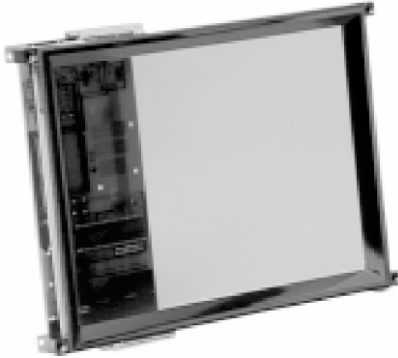

TIP products are infrared touch panels designed to fit most flat panel display technologies. The touch panels are a matrix of infrared diodes and detectors, scanning electronics, micro-processor controller, bezel/optical filter assembly and hardware to mount the touch panel and controller to the flat panel display. These touch panels are ideal for many applications including medical instrumentation, machine or process controls, point of sale devices, public information displays, banking and military.

Vishay Dale® TIP touch panels have a unique patented scanning I9ogic system that makes them virtually immune to most lighting environments.

Optional PC based software (TBDriver, a DOS mouse emulator; and TWDriver, a Windows® mouse emulator) provide simple touch panel integration.

Windows® is a registered trademark of the Microsoft Corporation.

FEATURES

- Fast response time
- Flexible operating modes
- User transparent
- Rugged construction
- Sealed for environmental resistance
- Immune to high or changing ambient light
- RS-232C interface
- Pre-assembled - no assembly or disassembly required to mount display

ELECTRICAL SPECIFICATIONS

Voltage: + 12 V_{DC} ± 5 %

Current: 400 mA typical

ENVIRONMENTAL SPECIFICATIONS

Operating Temperature: 0 °C to + 55 °C

Storage Temperature: - 55 °C to + 85 °C

Relative Humidity: 10 % to 90 % non-conditioning

INTERFACE

Type: RS-232C

Data Rate: 300 baud, 1200 baud, 9600 baud and auto baud

Word Format: 8 data bits, no parity, 1 start bit, 1 stop bit

ORDERING INFORMATION							
TIP	3216	FA			A	XXX	
MODEL	MATRIX	DISPLAY DESIGNATOR			FILTER ⁽¹⁾	DASH NUMBER (if required)	
TOUCH PANEL		DISPLAY					A = Non-polarized, gray B = Polarized, gray C = Non-polarized, amber D = Polarized, amber S = Special, contact factory
MATRIX	TOUCH POINTS	PIXELS	TECHNOLOGY	MANUFACTURER	PART NUMBER	DESIGNATOR	
3216	63 x 31	512 x 256	ELD	Finlux Planar	MD512.256 EL6648MSS	FA PA	
3220	63 x 39	640 x 400	ELD	Finlux Planar Sharp	MD640.400 EL8358HR LJ640U27	FB PB SA	
3224	63 x 47	640 x 480	ELD	Sharp	LJ64ZU49	SB	
3526	69 x 51	640 x 480	ELD	Planar	EL7768MS	PC	

Notes

⁽¹⁾ Other user specified filters will be designated as "S". Contact factory for availability. Any "S" filter designation will require a factory assigned dash number suffix. Filters A to D are plastic. Glass filters may be available on selected models.

- Many additional touch panel options available to fit color LCD's and other display technologies. Please contact factory for assistance.

DIMENSIONS in inches [millimeters]

TIP-3216 WITH FINLUX 512 x 256 DISPLAY

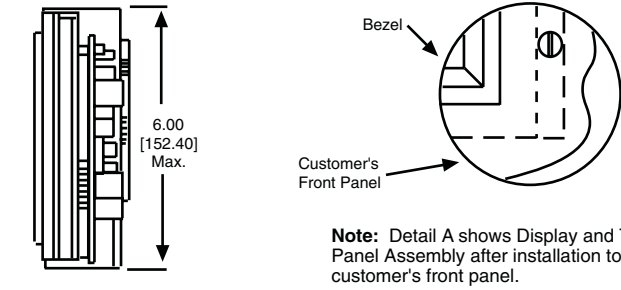
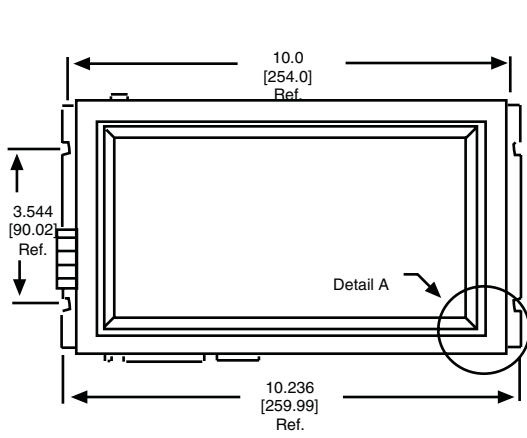

Note: Detail A shows Display and Touch Panel Assembly after installation to customer's front panel.

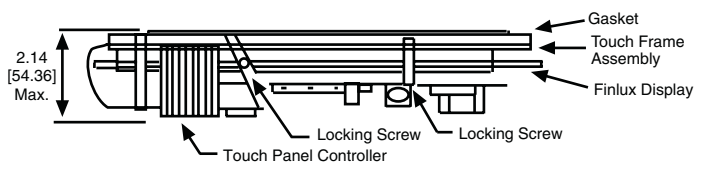

TIP-3220 WITH SHARP 640 x 400 DISPLAY

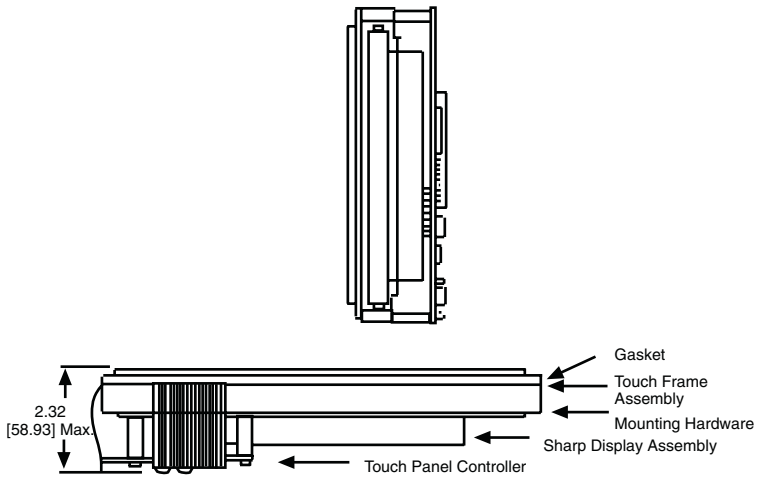
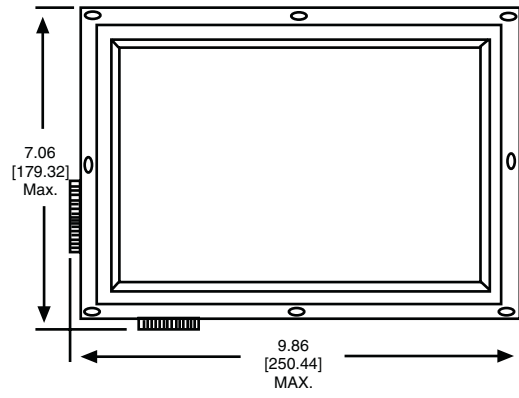

TIP-3220 WITH PLANAR 640 x 400 DISPLAY

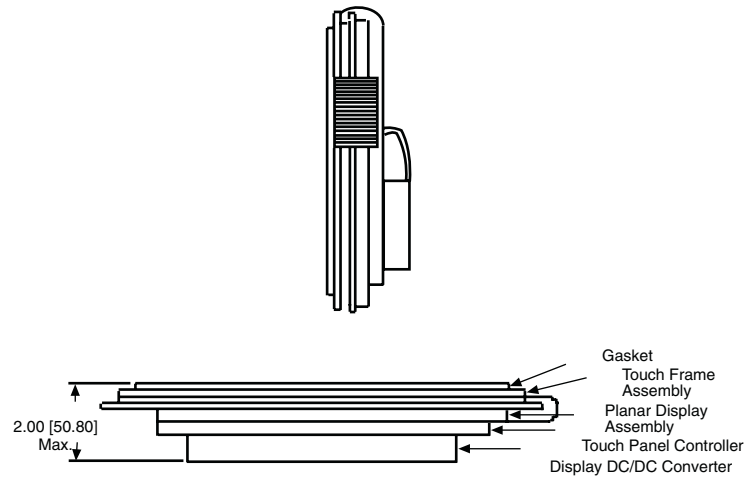
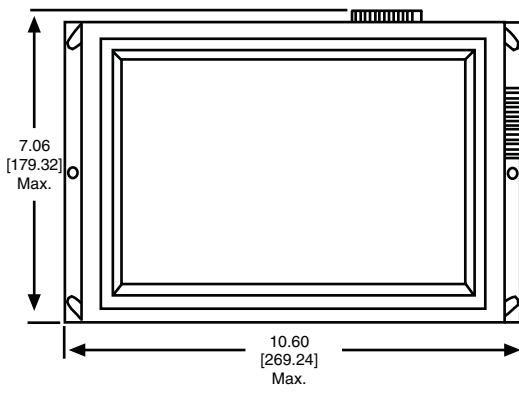

Note

- Contact factory for models not shown

GENERAL DESCRIPTION

Each Vishay Dale touch panel has infrared LED emitters and detectors along the X- and Y-axis, forming a grid of infrared light beams across the face of the display. The first two numbers of the TIP “matrix” number specify the number of vertical beams and the last two numbers specify the number of horizontal beams. The controller scans the emitter/detector pairs one at a time and determines whether both X and Y beams are blocked, indicating that a finger or stylus is present. (When beams are blocked on only one axis, they are ignored and not reported to the host.) The controller determines the coordinates of the touch point and reports them to the host computer. By interpolating a “virtual” beam between two physical beams, the number of touch points on each axis is effectively doubled. When an odd number of beams along either axis is blocked, the coordinate of the center physical beam is reported. When an even number of beams is blocked, the coordinate of the virtual beam in the center of the blocked beams is calculated and reported. The touch controller supports *enter*, *exit*, *continuous* and *tracking* report modes or combinations of these modes. The controller also has a beeper output. Hardware handshaking, software handshaking, baud rates and auto-baud features are jumper selected. The user initializes the desired report modes and requests reports when needed.

Several optical filters are standard to provide the most cost effective filter for each application. “Non-standard” filters may be specified as well. The filter increases the contrast ratio of the display and protects the display face and electronics.

Vishay Dale can assist in recommending the optimum filter based on years of experience as a display manufacturer. The perimeter of the filter is bonded to the bezel and a bezel to front panel gasket is included to provide a splash proof seal.

MATING CONNECTORS		
	VISHAY	OTHER
J1	280105-02	AMP 746285-1
J5, J6	280105-07	MOLEX 22-01-3037 housing, 08-50-0114 terminals
J4	280108-06	MOLEX 22-01-3037 housing, 08-50-0114 terminals

PIN CONNECTIONS			
J1 DATA CONNECTOR			
PIN	SIGNAL	PIN	SIGNAL
1	RD (to touch panel)	2	Ground
3	+ 12 (optional)	4	+ 12 (optional)
5	CTS	6	Reserved
7	RTS	8	Reserved
9	Ground	10	TD (from touch panel)
J5, J6 POWER CONNECTOR			
PIN	SIGNAL		
1	+ 12 V _{DC}		
2	Beeper signal (active low)		
J4 AUDIO FEED BACK CONNECTOR			
PIN	SIGNAL		
1	Ground		
2	Beeper signal (active low)		
3	+ 5 V _{DC}		

COMMAND SET (a bridged)	
11H	DC1, Ctl Q, XON software handshaking
13H	DC3, Ctl S, XOFF, Software handshaking
20H	Enable <i>exit</i> point mode
21H	Disable <i>exit</i> point mode (default)
22H	Enable <i>enter</i> point mode
23H	Disable <i>enter</i> point mode (default)
24H	Enable <i>continuous</i> mode/disable <i>tracking</i>
25H	Disable <i>continuous</i> mode (default) and <i>tracking</i>
26H	Enable touch panel
27H	Disable touch panel (default)
28H	Request Failed beam report
29H	Enable automatic report transfer
2AH	Disable automatic report transfer (default)
2BH	Request one coordinate report
2CH	Reset touch panel
2EH	Disable beeper (default)
2FxxH	Sound beep, xx = duration (00H to FFH)
34H	Enable <i>tracking</i> mode/disable <i>continuous</i>

TOUCH FRAME DIMENSIONS in inches [millimeters]

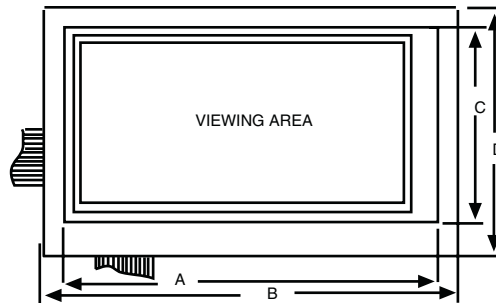

MODEL	B	C	D	VIEWING AREA
3216	9.608 [244.04]	4.86 [123.44]	5.67 [144.02]	7.9 x 4.1 [200.66 x 104.14]
3220	9.748 [247.60]	6.238 [158.45]	6.950 [176.53]	8.0 x 5.2 [203.20 x 132.08]
3224	9.680 [246.0]	6.687 [169.85]	7.086 [179.98]	7.8 x 5.9 [198.12 x 149.86]
3526	10.404 [264.26]	7.311 [185.70]	7.532 [191.31]	8.6 x 6.4 [218.44 x 162.56]



Disclaimer

ALL PRODUCT, PRODUCT SPECIFICATIONS AND DATA ARE SUBJECT TO CHANGE WITHOUT NOTICE TO IMPROVE RELIABILITY, FUNCTION OR DESIGN OR OTHERWISE.

Vishay Intertechnology, Inc., its affiliates, agents, and employees, and all persons acting on its or their behalf (collectively, "Vishay"), disclaim any and all liability for any errors, inaccuracies or incompleteness contained in any datasheet or in any other disclosure relating to any product.

Vishay makes no warranty, representation or guarantee regarding the suitability of the products for any particular purpose or the continuing production of any product. To the maximum extent permitted by applicable law, Vishay disclaims (i) any and all liability arising out of the application or use of any product, (ii) any and all liability, including without limitation special, consequential or incidental damages, and (iii) any and all implied warranties, including warranties of fitness for particular purpose, non-infringement and merchantability.

Statements regarding the suitability of products for certain types of applications are based on Vishay's knowledge of typical requirements that are often placed on Vishay products in generic applications. Such statements are not binding statements about the suitability of products for a particular application. It is the customer's responsibility to validate that a particular product with the properties described in the product specification is suitable for use in a particular application. Parameters provided in datasheets and / or specifications may vary in different applications and performance may vary over time. All operating parameters, including typical parameters, must be validated for each customer application by the customer's technical experts. Product specifications do not expand or otherwise modify Vishay's terms and conditions of purchase, including but not limited to the warranty expressed therein.

Except as expressly indicated in writing, Vishay products are not designed for use in medical, life-saving, or life-sustaining applications or for any other application in which the failure of the Vishay product could result in personal injury or death. Customers using or selling Vishay products not expressly indicated for use in such applications do so at their own risk. Please contact authorized Vishay personnel to obtain written terms and conditions regarding products designed for such applications.

No license, express or implied, by estoppel or otherwise, to any intellectual property rights is granted by this document or by any conduct of Vishay. Product names and markings noted herein may be trademarks of their respective owners.