



Wet Tantalum Hybrid Capacitors, High Energy, Ultra High Capacitance, -55 °C to +125 °C Operation



FEATURES

- High energy, very high capacitance design
- All tantalum, hermetically sealed case
- Utilizes Vishay-proven SuperTan® technology
- Terminations: radial leaded
- Approved to DLA land and maritime drawing 15010

PERFORMANCE CHARACTERISTICS

Operating Temperature:

-55 °C to +85 °C (to +125 °C with voltage derating)

Capacitance Tolerance:

at 120 Hz, +25 °C ± 20 % standard
± 10 % available as special

DC Leakage Current (DCL Max.):

at +25 °C: leakage current shall not exceed the values listed in the Standard Ratings table.

Life Test:

capacitors are capable of withstanding a 2000 h life test at a temperature of +85 °C at the applicable rated DC working voltage.

ORDERING INFORMATION				
15010	-01	M	L0	SM00
DLA DRAWING NUMBER	DASH NUMBER	CAPACITANCE TOLERANCE	OPTIONAL CENTER LEAD LENGTH	OPTIONAL STUD MOUNT
	See Standard Ratings table	K = ± 10 % ⁽¹⁾ M = ± 20 %	Blank = standard See TL table in Dimensions	Blank = no stud See SL table in Dimensions

Note

- Contact marketing for availability

DLA LAND AND MARITIME COLUMBUS, OHIO 43218-3990	DRAWING NUMBER 15010
--	-------------------------

DIMENSIONS in inches [millimeters]

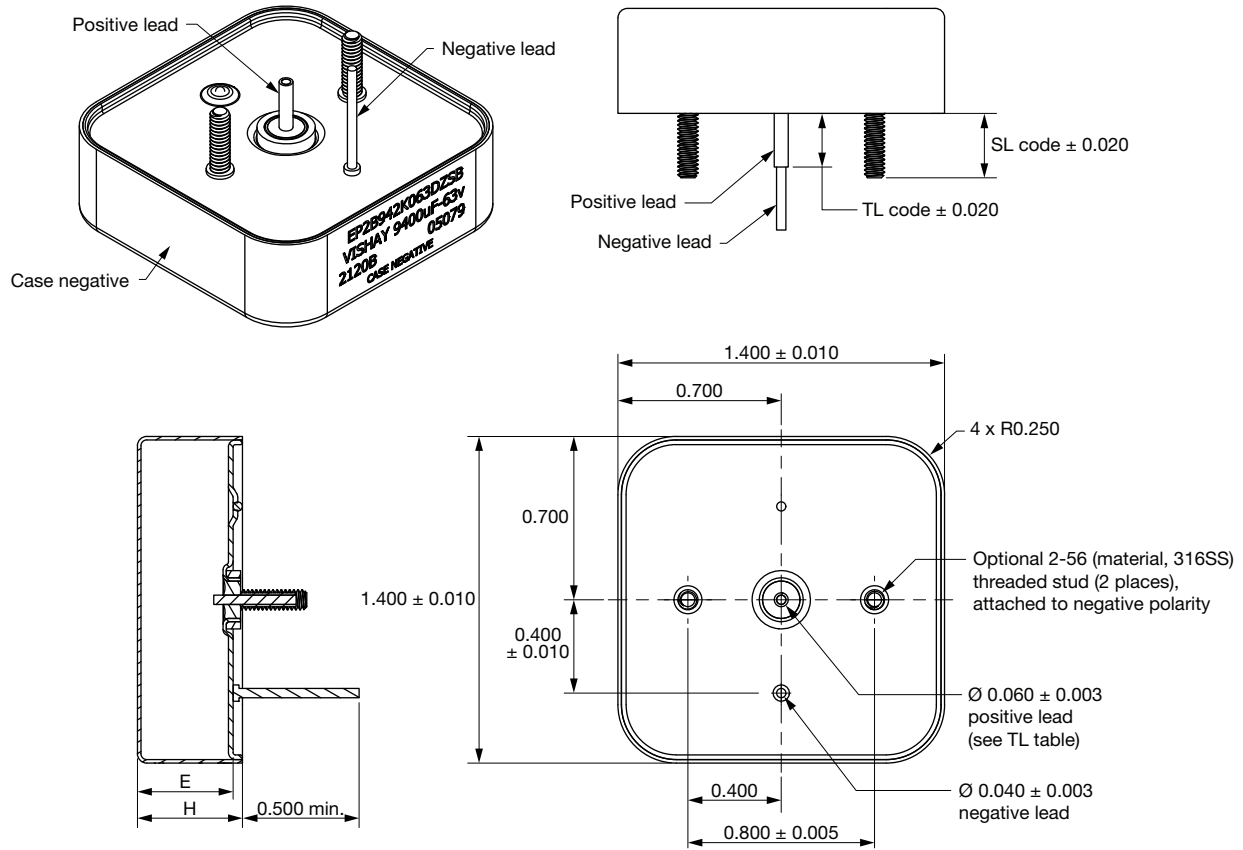

CASE SIZE	H	E (ref.)
A	0.312 ± 0.015 [7.92 ± 0.38]	0.272 [6.91]
B	0.450 ± 0.015 [11.43 ± 0.38]	0.410 [10.41]
C	0.600 ± 0.015 [15.24 ± 0.38]	0.560 [14.22]
D	0.755 ± 0.015 [19.18 ± 0.38]	0.715 [18.16]

POSITIVE TERMINAL LENGTH CODE [TL]	LENGTH
L0	0.125 [3.18]
L1	0.156 [3.96]
L2	0.188 [4.78]
L3	0.219 [5.56]
Blank	0.230 [5.84]
L4	0.250 [6.35]
L5	0.281 [7.14]
L6	0.313 [7.95]

MOUNTING STUDS LENGTH CODE [SL]	LENGTH
None	Blank
SM00	0.21 [5.33]
SM01	0.27 [6.86]
SM02	0.40 [10.16]
SM03	0.15 [3.81]
SM04	0.18 [4.57]
SM05	0.35 [8.89]



STANDARD RATINGS						
CAPACITANCE (μF)	CASE CODE	PART NUMBER	MAX. ESR AT +25 °C MAX. 1 kHz (Ω)	MAX. DCL AT +25 °C (μA)	WEIGHT (g)	
25 V_{DC} AT +85 °C; 15 V_{DC} AT +125 °C						
24 000 ⁽¹⁾	A	15010-09	0.030	150	-	
30 000 ⁽¹⁾	A	15010-xx	0.030	200	55	
48 000 ⁽¹⁾	B	15010-10	0.020	250	80	
72 000 ⁽¹⁾	C	15010-11	0.015	350	108	
35 V_{DC} AT +85 °C; 21 V_{DC} AT +125 °C						
32 000 ⁽¹⁾	B	15010-14	0.020	250	80	
48 000 ⁽¹⁾	C	15010-15	0.015	350	108	
50 V_{DC} AT +85 °C; 30 V_{DC} AT +125 °C						
11 000 ⁽¹⁾	A	15010-17	0.050	150	-	
22 000 ⁽¹⁾	B	15010-18	0.025	250	80	
33 000 ⁽¹⁾	C	15010-19	0.017	350	108	
44 000 ⁽¹⁾	D	15010-20	0.015	450	160	
60 V_{DC} AT +85 °C; 38 V_{DC} AT +125 °C						
12 600	B	15010-52	0.025	150	89	
19 000	C	15010-51	0.017	250	115	
63 V_{DC} AT +85 °C; 40 V_{DC} AT +125 °C						
9400	B	15010-22	0.025	150	86	
11 000	B	15010-53	0.025	150	90	
14 000	C	15010-23	0.017	200	115	
18 000	C	15010-54	0.020	250	120	
80 V_{DC} AT +85 °C; 50 V_{DC} AT +125 °C						
3000 ⁽¹⁾	A	15010-25	0.055	100	-	
4000 ⁽¹⁾	A	15010-xx	0.055	100	60	
6000 ⁽¹⁾	B	15010-26	0.027	150	86	
9000 ⁽¹⁾	B	15010-xx	0.030	200	92	
9000	C	15010-27	0.018	200	115	
100 V_{DC} AT +85 °C; 65 V_{DC} AT +125 °C						
2200 ⁽¹⁾	A	15010-29	0.065	100	-	
3000	A	15010-55	0.065	125	65	
4400 ⁽¹⁾	B	15010-30	0.030	150	86	
6600 ⁽¹⁾	C	15010-31	0.020	200	115	
110 V_{DC} AT +85 °C; 66 V_{DC} AT +125 °C						
2000 ⁽¹⁾	A	15010-37	0.085	100	60	
4000 ⁽¹⁾	B	15010-38	0.040	150	95	
6000 ⁽¹⁾	C	15010-39	0.027	200	128	
8000 ⁽¹⁾	D	15010-40	0.020	250	150	
125 V_{DC} AT +85 °C; 85 V_{DC} AT +125 °C						
1500 ⁽¹⁾	A	15010-33	0.060	50	60	
2000 ⁽¹⁾	A	15010-xx	0.100	100	63	
3600 ⁽¹⁾	B	15010-xx	0.050	150	95	
5600 ⁽¹⁾	C	15010-xx	0.035	250	135	

Note

⁽¹⁾ Preliminary rating, specification subject to change. Contact marketing for availability

CHECK DLA 15010 DRAWING FOR CURRENT DLA-APPROVED RATINGS



PERFORMANCE CHARACTERISTICS OF HIGH ENERGY CAPACITORS

ELECTRICAL PERFORMANCE CHARACTERISTICS	
ITEM	PERFORMANCE CHARACTERISTICS
Operating temperature range	-55 °C to +85 °C (to +125 °C with voltage derating)
Capacitor tolerance	± 20 % at 120 Hz
ESR	Limits per Standard Ratings table
DC leakage current (DCL max.)	At 25 °C the leakage current shall not exceed values listed in the Standard Rating table
Reverse voltage	No continuous reverse voltage permitted
Surge voltage	The test shall be at 1000 cycles at surge voltage (110 % of rated) at 85 °C. A cycle consists of a 30 s charge and a 330 s discharge through 1000 Ω resistor.
Life test	2000 h at +85 °C (at rated voltage) and 125 °C (at derated voltage)

ENVIRONMENTAL CHARACTERISTICS		
ITEM	TEST AND CONDITIONS	COMMENTS
Seal	MIL-STD-202, method 112 C/IIIa	The capacitor shall be hermetically sealed such that the case does not leak electrolyte or vent any gas when exposed to a vacuum.
Moisture resistance	MIL-STD-202, method 106	6 V polarity
Barometric pressure (reduced) / altitude	MIL-STD-202, method 105 C, test condition D	100 000 feet test

MECHANICAL PERFORMANCE CHARACTERISTICS		
ITEM	TEST METHOD	CONDITION
Thermal shock	MIL-STD-202, method 107 G	Test condition A
Shock	MIL-STD-202, method 213 B	Test condition G 11 ms, 50 g
Vibration - high frequency	MIL-STD-202, method 204 D	Test condition D 12 sweeps/axis, 20 g peak
Vibration - random	MIL-STD-202, method 214	Test condition II, letter E 1.5 h/axis, 19.64 g
Resistance to solder heat	MIL-STD-202, method 210 F	The capacitor must withstand solder dipping of the terminals at 260 °C for 10 s. The capacitor must not be visibly damaged, and the electrical characteristics must not be affected.
Solderability	MIL-STD-202, method 208	ANSI/J-STD-002, test A
Terminal strength	MIL-STD-202, method 211 A	The capacitor terminals must withstand a 5 pound pull test for 5 s to 10 s. The capacitor must not be visibly damaged, and the electrical characteristics must not be affected.
Resistance to solvents	MIL-STD-202, method 215 J	The capacitor shall be permanently and legibly marked on the circumference of the case. The markings shall be resistant to solvents.
Fungus resistance		The capacitor materials shall not support fungus growth and shall not be a nutrient to fungus.
Weight (mass)		See Standard Ratings table



High Energy Mounting FAQs

Capacitors mounted using leads only are not recommended for applications experiencing mechanical shock or vibration. Mounting studs can be provided and/or staking compounds should be used in high vibration environments. With the large mass of this type of component, secure mounting to the printed circuit board (PCB) is crucial, and combining methods is often preferred.

- **Mounting studs:** provide the strongest hold, especially in vibration environments. Vishay offers 2-56 316SS studs and spacers (to fill the gap) as standard options.
- **Epoxy staking:** even with studs, we recommend epoxy staking the capacitor to the PCB for maximum vibration resistance. In some cases, potting the cavity between the PCB and the capacitor body might be necessary. For the most demanding shock/vibration applications, full potting may be required.

RECOMMENDATIONS

- When using the stud option, use the (supplied) spacer to fill the gap between the PCB and the top of the capacitor. This spacer protrudes slightly above the capacitor top. Tighten the nuts on the studs only $\frac{1}{2}$ to $\frac{3}{4}$ turn beyond the initial point of contact, equivalent to 24 to 28 in-oz torque maximum. Maximum pre-load tension is about 15 pounds. Lock washers are not recommended. Use an adhesive locknut conforming to MIL-S-22473E, grade A - red.
- Handle the capacitor with care to avoid damaging the positive terminal Glass-to-Metal Seal (GTMS), which is a critical component for sealing and electrical performance. The tube should not be trimmed or bent; different tube lengths are available to meet your dimensional needs. Any force (lateral, axial, or torque) applied to the tube could cause damage, so it is important to minimize any mechanical shock to this area.

SOLDERING RECOMMENDATIONS

- The capacitor rim is designed to directly mate with the PCB. “No-clean” flux is recommended for soldering. Post solder cleaning is not required for electrical or mechanical performance when “no-clean” flux is used and properly processed.
- Follow standard ANSI J-STD 001 through-hole soldering methods.

LEAD TRIMMING

- If negative lead trimming is necessary, handle the leads with care.
- Cutting the positive terminal is strictly prohibited as it may result in “OPEN” failure mode.
- Leads are available from 0.1" to 0.313" (measured from the capacitor rim).

ADDITIONAL NOTES

- Consider these guidelines as recommendations for optimal performance and component longevity.
- Specific application requirements may necessitate adjustments to these guidelines.



Disclaimer

ALL PRODUCT, PRODUCT SPECIFICATIONS AND DATA ARE SUBJECT TO CHANGE WITHOUT NOTICE TO IMPROVE RELIABILITY, FUNCTION OR DESIGN OR OTHERWISE.

Vishay Intertechnology, Inc., its affiliates, agents, and employees, and all persons acting on its or their behalf (collectively, "Vishay"), disclaim any and all liability for any errors, inaccuracies or incompleteness contained in any datasheet or in any other disclosure relating to any product.

Vishay makes no warranty, representation or guarantee regarding the suitability of the products for any particular purpose or the continuing production of any product. To the maximum extent permitted by applicable law, Vishay disclaims (i) any and all liability arising out of the application or use of any product, (ii) any and all liability, including without limitation special, consequential or incidental damages, and (iii) any and all implied warranties, including warranties of fitness for particular purpose, non-infringement and merchantability.

Statements regarding the suitability of products for certain types of applications are based on Vishay's knowledge of typical requirements that are often placed on Vishay products in generic applications. Such statements are not binding statements about the suitability of products for a particular application. It is the customer's responsibility to validate that a particular product with the properties described in the product specification is suitable for use in a particular application. Parameters provided in datasheets and / or specifications may vary in different applications and performance may vary over time. All operating parameters, including typical parameters, must be validated for each customer application by the customer's technical experts. Product specifications do not expand or otherwise modify Vishay's terms and conditions of purchase, including but not limited to the warranty expressed therein.

Hyperlinks included in this datasheet may direct users to third-party websites. These links are provided as a convenience and for informational purposes only. Inclusion of these hyperlinks does not constitute an endorsement or an approval by Vishay of any of the products, services or opinions of the corporation, organization or individual associated with the third-party website. Vishay disclaims any and all liability and bears no responsibility for the accuracy, legality or content of the third-party website or for that of subsequent links.

Vishay products are not designed for use in life-saving or life-sustaining applications or any application in which the failure of the Vishay product could result in personal injury or death unless specifically qualified in writing by Vishay. Customers using or selling Vishay products not expressly indicated for use in such applications do so at their own risk. Please contact authorized Vishay personnel to obtain written terms and conditions regarding products designed for such applications.

No license, express or implied, by estoppel or otherwise, to any intellectual property rights is granted by this document or by any conduct of Vishay. Product names and markings noted herein may be trademarks of their respective owners.