



SuperTan® Wet Tantalum Capacitors With Hermetic Seal



LINKS TO ADDITIONAL RESOURCES



Vishay ST represents a major breakthrough in wet tantalum capacitor technology. Its unique cathode system provides the highest capacitance per unit volume. The design facilitates a doubling of capacitance, lower ESR and higher ripple current rating compared with conventional wet tantalum products. Moreover, the ST has the capacitance stability of a solid tantalum capacitor and there are no circuit impedance restrictions.

The ST is housed in an all tantalum, hermetically sealed case and is manufactured to withstand hazardous environments. The ST is used widely in the defense and aerospace industries and whenever there is a space problem.

PERFORMANCE CHARACTERISTICS

Operating Temperature: -55 °C to +85 °C
(to +125 °C with voltage derating)

Capacitance Tolerance: at 120 Hz, +25 °C.
± 20 % standard. ± 10 % available as special.

FEATURES

- Very high capacitance
- 10 µF to 2200 µF
- 25 V_{DC} to 125 V_{DC}
- Very low ESR
- High ripple current
- All tantalum case
- Hermetically sealed
- Low DCL
- Axial through-hole terminations: standard tin / lead (Sn / Pb), 100 % tin (RoHS-compliant) available
- Material categorization: for definitions of compliance please see www.vishay.com/doc?99912

Note

* This datasheet provides information about parts that are RoHS-compliant and / or parts that are non RoHS-compliant. For example, parts with lead (Pb) terminations are not RoHS-compliant. Please see the information / tables in this datasheet for details

APPLICATION NOTES

- No continuous reverse voltage permissible.
- The peak of the applied AC ripple and the applied DC voltage must not exceed the DC voltage rating of the capacitor.
- Ripple current ratings by part number at 85 °C and 40 kHz are included in the table. Ripple current correction factors for other temperatures and frequencies are given on the next page.
- Transient reverse voltage surges are acceptable under the following conditions:
the peak reverse voltage does not exceed 1.5 V and the peak current times the duration of the reverse transient does not exceed 0.05 As. In addition, the repetition frequency of the reverse voltage surge is less than 10 Hz.

ORDERING INFORMATION						
ST	220	100	T4	M	I ⁽¹⁾	E3 ⁽²⁾
TYPE	CAPACITANCE µF	DC VOLTAGE RATING AT +85 °C	CASE CODE	CAPACITANCE TOLERANCE	INSULATING SLEEVE	TERMINATION AND PACKAGING
				M = ± 20 % K = ± 10 %	I = insulated X = uninsulated	E3 = 100 % tin termination (RoHS-compliant) Blank = SnPb termination (standard design) J = SMD, outside bend, tin / lead K = SMD, outside bend, 100 % tin L = SMD, inside bend, tin / lead M = SMD, inside bend, 100 % tin

Notes

- Packaging: The use of formed plastic trays for packing bulk components is standard. Tape and reel cannot be used due to unit weight
- (1) Sleeve on J, K, L, M terminations shall be Kapton only
- (2) J, K, L, M are available in T4. For all other case sizes, check with marketing



AXIAL DIMENSIONS in inches [millimeters]

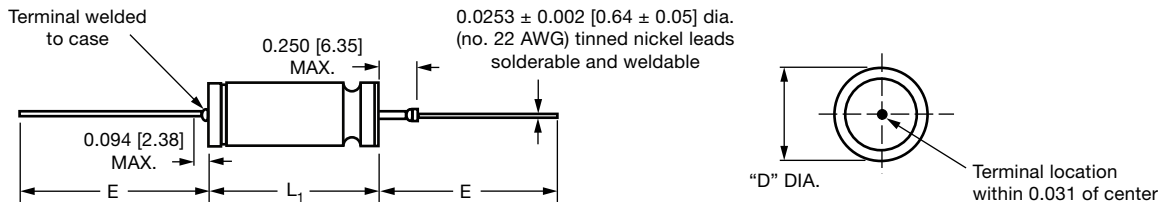

CASE CODE	D ± 0.016 [0.41]	MAX. INSULATED (DIA.)	L ₁ + 0.031 / - 0.016 [+ 0.79 / - 0.41] UNINSULATED	E ± 0.250 [6.3] MAX.
T1	0.188 [4.78]	0.219 [5.56]	0.453 [11.51]	1.500 [38.10]
T2	0.281 [7.14]	0.312 [7.92]	0.641 [16.28]	2.250 [57.15]
L2	0.281 [7.14]	0.312 [7.92]	1.008 [25.60]	2.250 [57.15]
T3	0.375 [9.52]	0.406 [10.31]	0.766 [19.46]	2.250 [57.15]
T4	0.375 [9.52]	0.406 [10.31]	1.062 [26.97]	2.250 [57.15]

Notes

- Material at egress is tantalum
- Insulation sleeving will lap over the ends of the capacitor case
- Approx. weight:
T1: 2.3 g, T2: 5.7 g,
T3: 9.4 g, T4: 14.8 g

SMD PRODUCT DIMENSIONS in inches [millimeters]

Styles J, K

Term. code	Solder type
J	SnPb
K	100 % tin (RoHS-compliant)

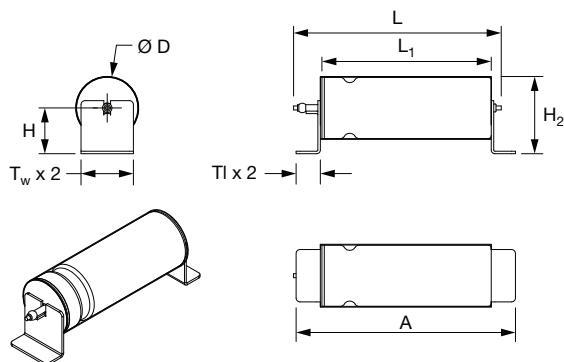

Styles L, M

Term. code	Solder type
L	SnPb
M	100 % tin (RoHS-compliant)

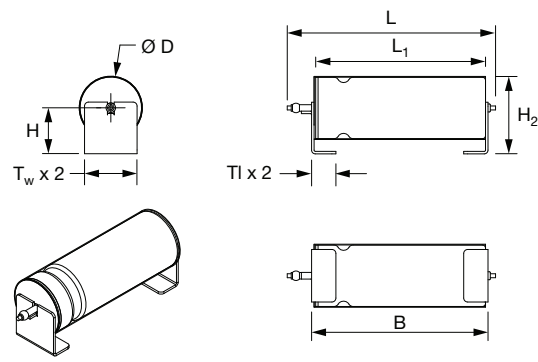

CASE CODE	A (max.)	B (max.)	TI (max.)	H (max.)	T _w ± 0.008	H ₂ (max.)	L (max.)	L ₁	D (max.)
T1	0.773 [19.6]	0.513 [13.0]	0.157 [4.0]	0.177 [4.5]	0.158 [4.0]	0.296 [7.5]	0.705 [17.9]	0.469 + 0.031 / - 0.016 [11.91 + 0.79 / - 0.41]	0.228 [5.8]
T2	1.001 [25.4]	0.720 [18.3]	0.157 [4.0]	0.212 [5.4]	0.217 [5.5]	0.374 [9.5]	0.903 [22.9]	0.668 + 0.012 / - 0.12 [16.97 + 0.30 / - 0.30]	0.316 [8.0]
L2	1.354 [34.4]	1.074 [27.3]	0.157 [4.0]	0.212 [5.4]	0.217 [5.5]	0.374 [9.5]	1.257 [31.9]	1.022 + 0.012 / - 0.12 [25.96 + 0.30 / - 0.30]	0.316 [8.0]
T3	1.143 [29]	0.858 [21.8]	0.157 [4.0]	0.280 [7.1]	0.331 [8.4]	0.492 [12.5]	1.051 [26.7]	0.806 + 0.012 / - 0.12 [20.47 + 0.30 / - 0.30]	0.397 [10.1]
T4	1.432 [36.4]	1.140 [29.0]	0.157 [4.0]	0.295 [7.5]	0.331 [8.4]	0.492 [12.5]	1.343 [34.1]	1.062 + 0.031 / - 0.016 [26.97 + 0.79 / - 0.41]	0.397 [10.1]

Note

- Use appropriate adhesive between capacitor body and the board for improved mechanical strength



RATINGS AND CASE CODES							
µF	25 V	30 V	50 V	60 V	75 V	100 V	125 V
10							T1
15						T1	
33					T1		
47				T1			T2
68			T1			T2	
82							T3
90							L2
100		T1					T3
110					T2		
120	T1					L2	
150				T2		T3	T4
220			T2			T4	
250					L2		
330					T3		
370				L2			
390				T3			
450			L2				
470		T2	T3		T4		
560	T2			T4			
680		T4	T4				
950		L2					
1000		T3		T4			
1100	L2						
1200	T3						
1500		T4					
1800	T4						
2200	T4						



STANDARD RATINGS										
CAPACITANCE AT 25 °C AND 120 Hz (μ F)	CASE CODE	MAX. ESR 120 Hz (Ω)	MAX. DCL AT		MAX. IMP. AT -55 °C AND 120 Hz (Ω)	MAX. CAPACITANCE CHANGE AT			AC RIPPLE 85 °C 40 kHz (mA) RMS	PART NUMBER (1)
			+25 °C (μ A)	+85 °C/ +125 °C (μ A)		-55 °C (%)	+85 °C (%)	+125 °C (%)		
25 V_{DC} AT 85 °C; 15 V_{DC} AT 125 °C										
120	T1	1.3	1	5	25	-42	+8	+12	1250	ST120-25T1MI
560	T2	0.83	2	10	12	-65	+10	+15	2100	ST560-25T2MI
1100	L2	0.5	3	25	7	-60	+20	+45	3200	ST1100-25L2MI
1200	T3	0.65	5	20	7	-70	+12	+18	2600	ST1200-25T3MI
1800	T4	0.5	6	25	7	-72	+12	+20	3100	ST1800-25T4MI
2200	T4	0.5	10	80	10	-90	+30	+50	3200	ST2200-25T4MI
30 V_{DC} AT 85 °C; 20 V_{DC} AT 125 °C										
100	T1	1.3	1	5	25	-38	+8	+12	1200	ST100-30TMI
470	T2	0.85	2	10	15	-65	+10	+18	1800	ST470-30T2MI
680	T4	0.7	5	40	8	-58	+10	+20	2750	ST680-30T4MI
950	L2	0.5	5	30	7	-55	+18	+35	3200	ST950-30L2MI
1000	T3	0.7	7	25	7	-70	+10	+18	2500	ST1000-30T3MI
1500	T4	0.6	12	35	6	-72	+10	+20	3000	ST1500-30T4MI
50 V_{DC} AT 85 °C; 30 V_{DC} AT 125 °C										
68	T1	1.5	1	5	35	-25	+8	+15	1050	ST68-50T1MI
220	T2	0.9	2	10	17.5	-50	+8	+15	1800	ST220-50T2MI
450	L2	0.6	3	25	7.5	-45	+12	+30	2900	ST450-50L2MI
470	T3	0.75	3	25	10	-45	+8	+15	2100	ST470-50T3MI
680	T4	0.7	5	40	8	-58	+10	+20	2750	ST680-50T4MI
60 V_{DC} AT 85 °C; 40 V_{DC} AT 125 °C										
47	T1	2.0	1	5	44	-25	+8	+12	1050	ST47-60T1MI
150	T2	1.1	2	10	20	-40	+8	+15	1800	ST150-60T2MI
370	L2	0.6	3	25	9	-33	+9	+20	2900	ST370-60L2MI
390	T3	0.9	3	25	15	-45	+8	+15	2100	ST390-60T3MI
560	T4	0.8	5	40	10	-58	+8	+15	2750	ST560-60T4MI
1000	T4	1.0	12	90	20	-90	+30	+50	3200	ST1000-60T4MI
75 V_{DC} AT 85 °C; 50 V_{DC} AT 125 °C										
33	T1	2.5	1	5	66	-25	+5	+9	1050	ST33-75T1MI
110	T2	1.3	2	10	24	-35	+6	+10	1650	ST110-75T2MI
250	L2	0.8	5	30	12	-30	+6	+15	2500	ST250-75L2MI
330	T3	1.0	3	30	12	-45	+6	+10	2100	ST330-75T3MI
470	T4	0.9	5	50	12	-50	+6	+10	2750	ST470-75T4MI
100 V_{DC} AT 85 °C; 65 V_{DC} AT 125 °C										
15	T1	3.5	1	5	125	-18	+3	+10	1050	ST15-100T1MI
68	T2	2.1	2	10	37	-30	+4	+12	1650	ST68-100T2MI
120	L2	1.0	3	25	20.5	-30	+4	+12	2200	ST120-100L2MI
150	T3	1.6	3	25	22	-35	+6	+12	2100	ST150-100T3MI
220	T4	1.2	5	50	15	-40	+6	+12	2750	ST220-100T4MI
125 V_{DC} AT 85 °C; 85 V_{DC} AT 125 °C										
10	T1	5.5	1	5	175	-15	+3	+10	1050	ST10-125T1MI
47	T2	2.3	2	10	47	-25	+5	+12	1650	ST47-125T2MI
90	L2	1.3	5	25	25	-22	+4	+15	2000	ST90-125L2MI
82	T3	1.8	3	25	40	-35	+5	+12	1950	ST82-125T3MI
100	T3	1.8	3	25	35	-35	+5	+12	2100	ST100-125T3MI
150	T4	1.6	5	50	20	-35	+6	+12	2750	ST150-125T4MI

Note

- (1) Part numbers shown are for units with $\pm 20\%$ capacitance tolerance and insulated capacitors.
 For units with $\pm 10\%$ capacitance tolerance change the letter "M" to "K".
 For units without insulation, substitute "X" for "I"



RIPPLE CURRENT MULTIPLIERS VS. FREQUENCY, TEMPERATURE, AND APPLIES PEAK VOLTAGE																									
FREQUENCY OF APPLIED RIPPLE CURRENT		120 Hz				800 Hz				1 kHz				10 kHz				40 kHz				100 kHz			
AMBIENT STILL AIR TEMP. IN °C		≤ 55	85	105	125	≤ 55	85	105	125	≤ 55	85	105	125	≤ 55	85	105	125	≤ 55	85	105	125	≤ 55	85	105	125
% of 85 °C rated peak voltage	100 %	0.60	0.39	-	-	0.71	0.43	-	-	0.72	0.46	-	-	0.88	0.55	-	-	1.0	0.63	-	-	1.1	0.69	-	-
	90 %	0.60	0.46	-	-	0.71	0.55	-	-	0.72	0.55	-	-	0.88	0.67	-	-	1.0	0.77	-	-	1.1	0.85	-	-
	80 %	0.60	0.52	0.35	-	0.71	0.62	0.42	-	0.72	0.62	0.42	-	0.88	0.76	0.52	-	1.0	0.87	0.59	-	1.1	0.96	0.65	-
	70 %	0.60	0.58	0.44	-	0.71	0.69	0.52	-	0.72	0.70	0.52	-	0.88	0.85	0.64	-	1.0	0.97	0.73	-	1.1	1.07	0.80	-
	66 2/3 %	0.60	0.60	0.46	0.27	0.71	0.71	0.55	0.32	0.72	0.72	0.55	0.32	0.88	0.88	0.68	0.40	1.0	1.0	0.77	0.45	1.1	1.1	0.85	0.50

TYPICAL PERFORMANCE CHARACTERISTICS OF ST CAPACITORS

ELECTRICAL CHARACTERISTICS	
ITEM	PERFORMANCE CHARACTERISTICS
Operating temperature range	-55 °C to +85 °C (to +125 °C with voltage derating)
Capacitor tolerance	± 20 %, ± 10 % at 120 Hz, at +25 °C
Capacitor change by temperature	Limit per Standard Ratings table
ESR	Limit per Standard Ratings table, at +25 °C, 120 Hz
Impedance	Limit per Standard Ratings table, at -55 °C, 120 Hz
DCL (leakage current)	Limit per Standard Ratings table
AC ripple current	Limit per Standard Ratings table, at +85 °C and 40 kHz
Reverse voltage	There shall be no continuous reverse voltage. Transient reverse voltage surges are acceptable under the following conditions: a) The peak reverse voltage is equal to or less than 1.5 V and the product of the peak current times the duration of the reverse transient is 0.05 As or less b) The repetition rate of the reverse voltage surges is less than 10 Hz
Surge voltage	Surge voltage shall be in accordance with MIL-PRF-39006 and Table II of DSCC93026. The DC rated surge voltage is the maximum voltage to which the capacitors can be subjected under any conditions including transients and peak ripple at the highest line voltage. The DC surge voltage is 115 % of rated DC voltage.

PERFORMANCE CHARACTERISTICS	
ITEM	PERFORMANCE CHARACTERISTICS
Life testing	Capacitors shall be capable of withstanding a 2000 h life test at a temperature +85 °C at rated voltage, or a 2000 h life test at 125 °C test at derated voltage. After the test, the capacitors shall meet the following requirements: a) DC leakage at 85 °C and 125 °C shall not exceed 125 % of the specified value b) DC leakage at 25 °C shall not exceed the specified value c) Capacitance shall be within +10 %, -20 % of initial value d) ESR shall not exceed 200 % of the specified value



ENVIRONMENTAL CHARACTERISTICS		
ITEM	CONDITION	COMMENTS
Seal	MIL-PRF-39006	When the capacitors are tested as specified in MIL-PRF-39006, there shall be no evidence of leakage.
Moisture resistance	MIL-PRF-39006	Moisture resistance shall be in accordance with MIL-PRF-39006. Number of cycles: 10 continuous cycles
Barometric pressure (reduced)	MIL-STD-202, method 105, condition E	Altitude 150 000 feet

MECHANICAL CHARACTERISTICS		
ITEM	TEST METHOD	CONDITION
Shock (specified pulse)	MIL-STD-202, method 213	Test condition I (100 g)
Vibration, high frequency	MIL-STD-202, method 204	Test condition D (20 g peak)
Thermal shock	MIL-STD-202, method 107	Test condition A, 30 cycles
Solderability	MIL-STD-202, method 208	ANSI/J-STD-002, test A Solderability shall be in accordance with MIL-PRF-39006.
Terminal strength	MIL-STD-202, method 211	Terminal strength shall be in accordance with MIL-PRF-39006.
Resistance to solder heat	MIL-STD-202, method 210	Test condition C The capacitors shall meet the requirements of MIL-PRF-39006.
Terminals	MIL-STD-1276	Terminals shall be as specified in MIL-STD-1276. The length and diameter of the terminals shall be as specified in Dimensions table. All terminals shall be permanently secured internally and externally, as applicable. All external joints shall be welded.
Marking	MIL-STD-1285	Marking of capacitors conforms to method I of MIL-STD-1285 and include capacitance (in μF), capacitance tolerance letter, rated voltage, date code, lot symbol and Vishay trademark.

SELECTOR GUIDES	
Tantalum Selector Guide	www.vishay.com/doc?49054
Parameter Comparison Guide	www.vishay.com/doc?42088



Disclaimer

ALL PRODUCT, PRODUCT SPECIFICATIONS AND DATA ARE SUBJECT TO CHANGE WITHOUT NOTICE TO IMPROVE RELIABILITY, FUNCTION OR DESIGN OR OTHERWISE.

Vishay Intertechnology, Inc., its affiliates, agents, and employees, and all persons acting on its or their behalf (collectively, "Vishay"), disclaim any and all liability for any errors, inaccuracies or incompleteness contained in any datasheet or in any other disclosure relating to any product.

Vishay makes no warranty, representation or guarantee regarding the suitability of the products for any particular purpose or the continuing production of any product. To the maximum extent permitted by applicable law, Vishay disclaims (i) any and all liability arising out of the application or use of any product, (ii) any and all liability, including without limitation special, consequential or incidental damages, and (iii) any and all implied warranties, including warranties of fitness for particular purpose, non-infringement and merchantability.

Statements regarding the suitability of products for certain types of applications are based on Vishay's knowledge of typical requirements that are often placed on Vishay products in generic applications. Such statements are not binding statements about the suitability of products for a particular application. It is the customer's responsibility to validate that a particular product with the properties described in the product specification is suitable for use in a particular application. Parameters provided in datasheets and / or specifications may vary in different applications and performance may vary over time. All operating parameters, including typical parameters, must be validated for each customer application by the customer's technical experts. Product specifications do not expand or otherwise modify Vishay's terms and conditions of purchase, including but not limited to the warranty expressed therein.

Hyperlinks included in this datasheet may direct users to third-party websites. These links are provided as a convenience and for informational purposes only. Inclusion of these hyperlinks does not constitute an endorsement or an approval by Vishay of any of the products, services or opinions of the corporation, organization or individual associated with the third-party website. Vishay disclaims any and all liability and bears no responsibility for the accuracy, legality or content of the third-party website or for that of subsequent links.

Vishay products are not designed for use in life-saving or life-sustaining applications or any application in which the failure of the Vishay product could result in personal injury or death unless specifically qualified in writing by Vishay. Customers using or selling Vishay products not expressly indicated for use in such applications do so at their own risk. Please contact authorized Vishay personnel to obtain written terms and conditions regarding products designed for such applications.

No license, express or implied, by estoppel or otherwise, to any intellectual property rights is granted by this document or by any conduct of Vishay. Product names and markings noted herein may be trademarks of their respective owners.