

SuperTan[®] Extended (STE) Capacitors, Wet Tantalum Capacitors With Hermetic Seal

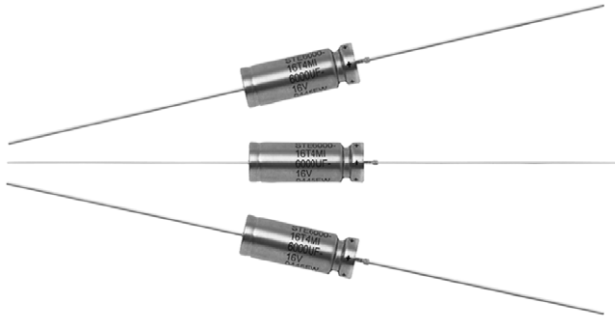

FEATURES

Vishay SuperTan[®] Extended (STE) represents a major breakthrough in wet tantalum capacitor technology. Its unique cathode system, also used in the ST, provides the highest capacitance per unit volume available. The STE combines the inherent reliability of wet tantalum with the capacitance stability of solid tantalum, and there are no circuit impedance restrictions. The range is exceptionally well suited for low voltage filtering and energy storage applications. Ideal for designs targeting the military and aerospace industry.



The SuperTan[®] Extended (STE) is housed in an all tantalum, hermetically sealed case and is manufactured to withstand high stress and hazardous environments.

- Axial through-hole terminations: standard tin / lead (Sn / Pb), 100 % tin (RoHS-compliant) available
- Material categorization: for definitions of compliance please see www.vishay.com/doc?99912

Note

* This datasheet provides information about parts that are RoHS-compliant and / or parts that are non RoHS-compliant. For example, parts with lead (Pb) terminations are not RoHS-compliant. Please see the information / tables in this datasheet for details

PERFORMANCE CHARACTERISTICS

Operating Temperature: -55 °C to +85 °C
(to +125 °C with voltage derating)

Capacitance Tolerance: at 120 Hz, +25 °C.
± 20 % standard. ± 10 % available as special.

DC Leakage Current (DCL Max.): at +25 °C and above: leakage current shall not exceed the values listed in the Standard Ratings tables.

Life Test: capacitors are capable of withstanding a 2000 h life test at a temperature of +85 °C at the applicable rated DC working voltage.

ORDERING INFORMATION

STE	6000	16	T4	M	I	E3
TYPE	CAPACITANCE µF	DC VOLTAGE RATING AT +85 °C	CASE SIZE	CAPACITANCE TOLERANCE	INSULATING SLEEVE	RoHS COMPLIANT
				M = ± 20 % K = ± 10 %	I = insulated X = uninsulated	E3 = 100 % tin termination (RoHS compliant) Blank = SnPb termination (standard design)

Note

- Packaging: the use of formed plastic trays for packaging this type of axial lead component is standard. Tape and reel is not recommended due to the unit weight.

DIMENSIONS in inches [millimeters]				
CASE CODE	D ± 0.016 [0.41]	MAX. INSULATED (DIA.)	L ₁ + 0.031 / - 0.016 [+ 0.79 / - 0.41] UNINSULATED	E ± 0.250 [6.35] MAX.
T1	0.188 [4.78]	0.219 [5.56]	0.453 [11.51]	1.500 [38.10]
T2	0.281 [7.14]	0.312 [7.92]	0.641 [16.28]	2.250 [57.15]
T3	0.375 [9.52]	0.406 [10.31]	0.766 [19.46]	2.250 [57.15]
T4	0.375 [9.52]	0.406 [10.31]	1.062 [26.97]	2.250 [57.15]

Notes

- Material at egress is tantalum
- Insulation sleeving will lap over the ends of the capacitor case
- Approx. weight:
T1: 2.3 g, T2: 5.7 g
T3: 9.4 g, T4: 14.8 g

STANDARD RATINGS												
CAPACITANCE (μF)	VOLTAGE	CASE CODE	PART NUMBER (1)	MAX. ESR AT +25 °C 120 Hz (Ω)	TYP. ESR AT +25 °C 1 kHz (Ω)	MAX. DCL AT +25 °C (μA)	+85 °C / +125 °C (μA)	MAX. CAPACITANCE CHANGE AT -55 °C (%)	+85 °C (%)	+125 °C (%)	MAX. IMP. AT -55 °C 120 Hz (Ω)	AC RIPPLE 85 °C 40 kHz mA RMS
10 V_{DC} AT +85 °C; 7 V_{DC} AT +125 °C												
680	10	T1	<i>Preliminary value, contact marketing</i>									
2000	10	T2	<i>Preliminary value, contact marketing</i>									
4700	10	T3	STE4700-10T3MI	0.35	< 0.200	16	100	-80	10	20	3.50	4000
10 000	10	T4	STE10000-10T4MI	0.25	< 0.100	25	150	-85	20	35	3.00	5000
16 V_{DC} AT +85 °C; 11 V_{DC} AT +125 °C												
430	16	T1	<i>Preliminary value, contact marketing</i>									
1200	16	T2	<i>Preliminary value, contact marketing</i>									
3300	16	T3	STE3300-16T3MI	0.35	< 0.200	16	100	-80	10	15	3.50	4000
6000	16	T4	STE6000-16T4MI	0.30	< 0.150	25	150	-80	15	20	3.00	4500
25 V_{DC} AT +85 °C; 15 V_{DC} AT +125 °C												
270	25	T1	<i>Preliminary value, contact marketing</i>									
1000	25	T2	<i>Preliminary value, contact marketing</i>									
2200	25	T3	<i>Preliminary value, contact marketing</i>									
4000	25	T4	STE4000-25T4MI	0.35	< 0.150	25	125	-80	15	20	5.00	4250
30 V_{DC} AT +85 °C; 20 V_{DC} AT +125 °C												
220	30	T1	<i>Preliminary value, contact marketing</i>									
820	30	T2	STE820-30T2MI	1.00	< 0.600	3.5	18	-75	12	20	20.00	1650
1800	30	T3	<i>Preliminary value, contact marketing</i>									
3300	30	T4	STE3300-30T4MI	0.35	< 0.200	25	125	-80	20	25	4.00	2750
35 V_{DC} AT +85 °C; 22 V_{DC} AT +125 °C												
180	35	T1	<i>Preliminary value, contact marketing</i>									
680	35	T2	STE680-35T2MI	0.95	< 0.500	5	25	-75	16	20	16.00	2500
1500	35	T3	<i>Preliminary value, contact marketing</i>									
2800	35	T4	STE2800-35T4MI	0.35	< 0.200	25	125	-80	20	30	4.50	4000

Notes

- Part numbers shown are for units with ± 20 % capacitance tolerance and insulated capacitors. For units with ± 10 % capacitance tolerance change the letter "M" to "K". For units without insulation, substitute "X" with "I" at the end of the part number. For RoHS-compliant add the "E3" for suffix
- Requires export license for shipments outside the US. Contact marketing for availability



STANDARD RATINGS													
CAPACITANCE (μ F)	VOLTAGE	CASE CODE	PART NUMBER (1)	MAX. ESR AT	TYP. ESR AT	MAX. DCL AT		MAX. CAPACITANCE CHANGE AT			MAX. IMP. AT	AC RIPPLE	
				+25 °C 120 Hz (Ω)	+25 °C 1 kHz (Ω)	+25 °C (μ A)	+85 °C / +125 °C (μ A)	-55 °C (%)	+85 °C (%)	+125 °C (%)	-55 °C 120 Hz (Ω)	85 °C 40 kHz mA RMS	
50 V_{DC} AT +85 °C; 30 V_{DC} AT +125 °C													
110	50	T1	STE110-50T1MI	1.60	< 1.000	2	7.5	-40	10	15	40.00	1500	
470	50	T2	STE470-50T2MI	0.90	< 0.600	5	50	-60	8	12	12.00	2000	
520	50	T2	STE520-50T2MI	1.00	< 0.600	3	15	-80	12	18	20.00	1700	
900	50	T3	STE900-50T3MI	0.90	< 0.300	15	125	-75	20	20	10.00	2500	
1500	50	T3	STE1500-50T3MI	1.00	< 0.300	25	130	-85	25	30	8.00	2400	
1500	50	T4	STE1500-50T4MI	0.35	< 0.215	15	110	-70	20	20	6.00	3500	
2200	50	T4	STE2200-50T4MI	0.60	< 0.400	25	125	-80	25	30	4.50	3000	
60 V_{DC} AT +85 °C; 40 V_{DC} AT +125 °C													
68	60	T1	STE68-60T1MI	1.50	< 0.600	1.5	7.5	-30	10	12	40.00	1400	
220	60	T2	<i>Preliminary value, contact marketing</i>										
560	60	T3	STE560-60T3MI	0.90	< 0.300	20	120	-70	12	15	10.00	2500	
1000	60	T4	STE1000-60T4MI	0.50	< 0.300	20	120	-40	10	15	5.50	3500	
1800	60	T4 (2)	STE1800-60T4MI	0.50	< 0.300	25	250	-75	25	25	6.00	3000	
75 V_{DC} AT +85 °C; 50 V_{DC} AT +125 °C													
56	75	T1	STE56-75T1MI	1.60	< 0.800	1.5	7.5	-30	8	10	40.00	1750	
180	75	T2	STE180-75T2MI	1.50	< 0.500	5	25	-35	15	20	30.00	2000	
470	75	T3	STE470-75T3MI	0.60	< 0.325	25	100	-45	10	25	10.00	3000	
750	75	T4	STE750-75T4MI	0.50	< 0.400	20	120	-35	10	15	6.50	3500	
1200	75	T4 (2)	STE1200-75T4MI	0.80	< 0.350	25	250	-75	25	35	8.00	2750	
100 V_{DC} AT +85 °C; 65 V_{DC} AT +125 °C													
22	100	T1	STE22-100T1MI	3.00	< 1.500	1	5	-15	4	10	100.00	1200	
86	100	T2	<i>Preliminary value, contact marketing</i>										
220	100	T3	STE220-100T3MI	1.40	< 0.200	5	25	-55	10	15	18.00	2500	
400	100	T4	STE400-100T4MI	0.70	< 0.400	10	120	-40	6	12	15.00	3000	
125 V_{DC} AT +85 °C; 85 V_{DC} AT +125 °C													
18	125	T1	<i>Preliminary value, contact marketing</i>										
56	125	T2	<i>Preliminary value, contact marketing</i>										
150	125	T3	<i>Preliminary value, contact marketing</i>										
240	125	T4	STE240-125T4MI	0.80	< 0.600	15	150	-35	6	12	20.00	2500	

Notes

- (1) Part numbers shown are for units with $\pm 20\%$ capacitance tolerance and insulated capacitors. For units with $\pm 10\%$ capacitance tolerance change the letter "M" to "K". For units without insulation, substitute "X" with "I" at the end of the part number. For RoHS-compliant add the "E3" for suffix
- (2) Requires export license for shipments outside the US. Contact marketing for availability



TYPICAL PERFORMANCE CHARACTERISTICS OF STE CAPACITORS

ELECTRICAL CHARACTERISTICS	
ITEM	PERFORMANCE CHARACTERISTICS
Operating temperature range	-55 °C to +85 °C (to +125 °C with voltage derating)
Capacitor tolerance	± 20 %, ± 10 % at 120 Hz, at +25 °C
Capacitor change by temperature	Limit per Standard Ratings table
ESR	Limit per Standard Ratings table, at +25 °C, 120 Hz
Impedance	Limit per Standard Ratings table, at -55 °C, 120 Hz
DCL (leakage current)	Limit per Standard Ratings table
AC ripple current	Limit per Standard Ratings table, at +85 °C and 40 kHz
Reverse voltage	There shall be no continuous reverse voltage. Transient reverse voltage surges are acceptable under the following conditions: a) The peak reverse voltage is equal to or less than 1.5 V and the product of the peak current times the duration of the reverse transient is 0.05 As or less b) The repetition rate of the reverse voltage surges is less than 10 Hz
Surge voltage	Surge voltage shall be in accordance with MIL-PRF-39006 and Table I of DLA 10004. The DC rated surge voltage is the maximum voltage to which the capacitors can be subjected under any conditions including transients and peak ripple at the highest line voltage. The DC surge voltage is 115 % of rated DC voltage.

PERFORMANCE CHARACTERISTICS	
ITEM	PERFORMANCE CHARACTERISTICS
Life testing	Capacitors shall be capable of withstanding a 2000 h life test at a temperature +85 °C at rated voltage, or a 2000 h life test at 125 °C test at derated voltage. After the test, the capacitors shall meet the following requirements: a) DC leakage at 85 °C and 125 °C shall not exceed 125 % of the specified value b) DC leakage at 25 °C shall not exceed the specified value c) Capacitance shall be within +10 %, -20 % of initial value d) ESR shall not exceed 200 % of the specified value

ENVIRONMENTAL CHARACTERISTICS		
ITEM	CONDITION	COMMENTS
Seal	MIL-PRF-39006	When the capacitors are tested as specified in MIL-PRF-39006, there shall be no evidence of leakage.
Moisture resistance	MIL-PRF-39006	Moisture resistance shall be in accordance with MIL-PRF-39006. Number of cycles: 10 continuous cycles
Barometric pressure (reduced)	MIL-STD-202, method 105, condition E	Altitude 150 000 feet



MECHANICAL CHARACTERISTICS		
ITEM	CONDITION	COMMENTS
Shock (specified pulse)	MIL-STD-202, method 213, condition I (100 g)	The capacitors shall meet the requirements of MIL-PRF-39006.
Vibration, high frequency	MIL-STD-202, method 204, condition D (20 g peak)	The capacitors shall meet the requirements of MIL-PRF-39006.
Thermal shock	MIL-STD-202, method 107, condition A	Thermal shock shall be in accordance with MIL-PRF-39006 when tested for 30 cycles.
Solderability	MIL-STD-202, method 208, ANSI/J-STD-002, test A	Solderability shall be in accordance with MIL-PRF-39006.
Terminal strength	MIL-STD-202, method 211	Terminal strength shall be in accordance with MIL-PRF-39006.
Resistance to solder heat	MIL-STD-202, method 210, condition C	The capacitors shall meet the requirements of MIL-PRF-39006.
Terminals	MIL-STD-1276	Terminals shall be as specified in MIL-STD-1276. The length and diameter of the terminals shall be as specified in Dimensions table. All terminals shall be permanently secured internally and externally, as applicable. All external joints shall be welded.
Marking	MIL-STD-1285	Marking of capacitors conforms to method I of MIL-STD-1285 and include capacitance (in μF), capacitance tolerance letter, rated voltage, date code, lot symbol and Vishay trademark.

SELECTOR GUIDES	
Tantalum Selector Guide	www.vishay.com/doc?49054
Parameter Comparison Guide	www.vishay.com/doc?42088



Disclaimer

ALL PRODUCT, PRODUCT SPECIFICATIONS AND DATA ARE SUBJECT TO CHANGE WITHOUT NOTICE TO IMPROVE RELIABILITY, FUNCTION OR DESIGN OR OTHERWISE.

Vishay Intertechnology, Inc., its affiliates, agents, and employees, and all persons acting on its or their behalf (collectively, "Vishay"), disclaim any and all liability for any errors, inaccuracies or incompleteness contained in any datasheet or in any other disclosure relating to any product.

Vishay makes no warranty, representation or guarantee regarding the suitability of the products for any particular purpose or the continuing production of any product. To the maximum extent permitted by applicable law, Vishay disclaims (i) any and all liability arising out of the application or use of any product, (ii) any and all liability, including without limitation special, consequential or incidental damages, and (iii) any and all implied warranties, including warranties of fitness for particular purpose, non-infringement and merchantability.

Statements regarding the suitability of products for certain types of applications are based on Vishay's knowledge of typical requirements that are often placed on Vishay products in generic applications. Such statements are not binding statements about the suitability of products for a particular application. It is the customer's responsibility to validate that a particular product with the properties described in the product specification is suitable for use in a particular application. Parameters provided in datasheets and / or specifications may vary in different applications and performance may vary over time. All operating parameters, including typical parameters, must be validated for each customer application by the customer's technical experts. Product specifications do not expand or otherwise modify Vishay's terms and conditions of purchase, including but not limited to the warranty expressed therein.

Except as expressly indicated in writing, Vishay products are not designed for use in medical, life-saving, or life-sustaining applications or for any other application in which the failure of the Vishay product could result in personal injury or death. Customers using or selling Vishay products not expressly indicated for use in such applications do so at their own risk. Please contact authorized Vishay personnel to obtain written terms and conditions regarding products designed for such applications.

No license, express or implied, by estoppel or otherwise, to any intellectual property rights is granted by this document or by any conduct of Vishay. Product names and markings noted herein may be trademarks of their respective owners.