

Power Metal Strip® Resistors Optimized for Current Sensing

KEY BENEFITS

Vishay's Power Metal Strip® resistors are optimized for current sensing in a wide range of electronic systems. Their low ohmic resistance, in combination with low TCR and low thermal EMF, makes Power Metal Strip products the resistors of choice for high current and high power applications in all market segments.

- Resistance from 0.000015 Ω to 1 Ω
- Resistance tolerance down to 0.1 %
- Very low inductance of < 5 nH
- Low thermal EMF down to < 1 $\mu\text{V}/^\circ\text{C}$
- Lead (Pb)-free available
- Low TCR metal resistive element (< 20 ppm/ $^\circ\text{C}$)
- Operating temperature range of -65°C to $+275^\circ\text{C}$

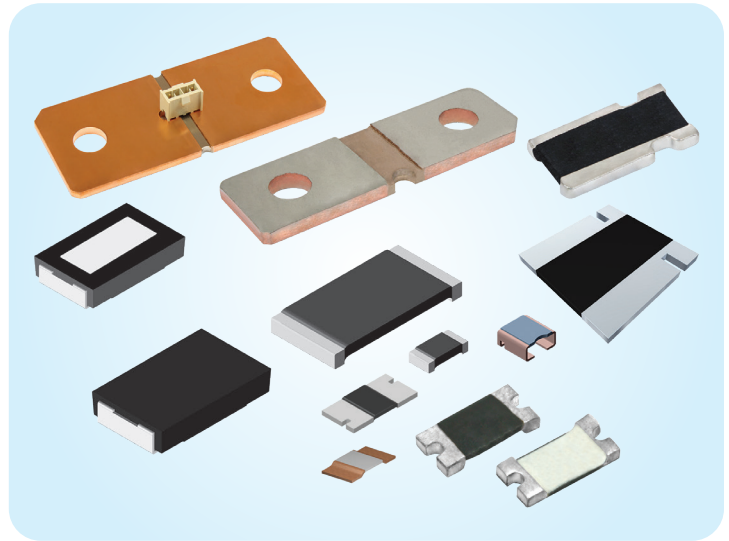

RESOURCES

- Technical note: Components and Methods for Current Measurement <https://www.vishay.com/doc?30304>
- For technical questions contact ww2bresistors@vishay.com
- Sales contacts: www.vishay.com/doc?99914



The DNA of tech.®

Power Metal Strip® Resistors

Vishay Dale

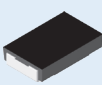

Product	Power Rating P70 °C	Maximum Current	Features	Dimensions	Applications
High Current, Standard, Power Metal Strip® Resistors					
WSK1216 	8 W	200 A	<ul style="list-style-type: none"> 0.0002 Ω to 0.002 Ω ± 1.0 % Low TCR element (< 20 ppm/°C) High power 4-terminal 	Available in standard 1216 size L = 0.150 in [3.81 mm] W = 0.122 in [3.1 mm] H = 0.075 in [1.9 mm]	<ul style="list-style-type: none"> DC/DC converters in switching power supplies Inverter controls for LDC motor drives Automotive controls for EHPS / EPS / EPaS
WSK1206 	0.25 W	5 A	<ul style="list-style-type: none"> 0.01 Ω to 0.05 Ω ± 0.1 % / ± 1.0 % Low TCR element (< 20 ppm/°C) High power 4-terminal 	Available in standard 1206 size L = 0.126 in [3.20 mm] W = 0.063 in [1.60 mm] H = 0.025 in [0.635 mm]	<ul style="list-style-type: none"> DC/DC converters in switching power supplies VRMs in notebooks / desktop PCs Instrumentation Automotive controls for body and powertrains
WSK1206...18 	0.5 W	7 A	<ul style="list-style-type: none"> 0.01 Ω to 0.05 Ω ± 0.1 % / ± 1.0 % Low TCR element (< 20 ppm/°C) High power 4-terminal 	Available in standard 1206 size L = 0.126 in [3.20 mm] W = 0.063 in [1.60 mm] H = 0.025 in [0.635 mm]	<ul style="list-style-type: none"> DC/DC converters in switching power supplies VRMs in notebooks / desktop PCs Instrumentation Automotive controls for body and powertrains
WSK2512 	1 W	45 A	<ul style="list-style-type: none"> 0.0005 Ω to 0.2 Ω ± 0.1 % / ± 1.0 % Low TCR element (< 20 ppm/°C) 4-terminal 	Available in standard 2512 size L = 0.250 in [6.35 mm] W = 0.125 in [3.18 mm] H = 0.025 in [0.635 mm]	<ul style="list-style-type: none"> DC/DC converters in switching power supplies VRMs in notebooks / desktop PCs Instrumentation Automotive controls for body and powertrains
WSKP0612 	5 W	100 A	<ul style="list-style-type: none"> 0.0005 Ω to 0.005 Ω ± 1.0 % / ± 5.0 % Low TCR element (< 20 ppm/°C) High power 4-terminal 	Available in standard 0612 size L = 0.060 in [1.50 mm] W = 0.120 in [3.05 mm] H = 0.018 in [0.457 mm]	<ul style="list-style-type: none"> DC/DC converters in switching power supplies VRMs in notebooks / desktop PCs Instrumentation Automotive controls for body and powertrains
WSR2  WSR3	2 W 3 W	45 A 55 A	<ul style="list-style-type: none"> 0.001 Ω to 1.0 Ω ± 0.5 % / ± 1.0 % Molded high temperature encapsulation Low TCR element (< 20 ppm/°C) 	Available in standard 4527 size L = 0.455 in [11.56 mm] W = 0.275 in [6.98 mm] H = 0.095 in [2.41 mm]	<ul style="list-style-type: none"> DC/DC converters in switching power supplies VRMs in notebooks / desktop PCs Instrumentation Automotive controls for body and powertrains
WSR 5 	5 W	22 A	<ul style="list-style-type: none"> 0.01 Ω to 0.3 Ω ± 0.5 % / ± 1.0 % High power Molded high temperature encapsulation Low TCR element (< 20 ppm/°C) 	Available in standard 4527 size L = 0.455 in [11.56 mm] W = 0.275 in [6.98 mm] H = 0.095 in [2.41 mm]	<ul style="list-style-type: none"> DC/DC converters in switching power supplies VRMs in notebooks / desktop PCs Instrumentation Automotive controls for body and powertrains



The DNA of tech.®

Power Metal Strip® Resistors

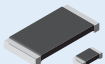
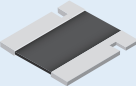
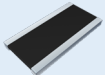
Vishay Dale

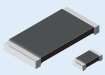
Product	Power Rating P70 °C	Maximum Current	Features	Dimensions	Applications
WSL...9 Jumper 	8 W	200 A	<ul style="list-style-type: none"> 0.0002 Ω to 0.00025 Ω Tolerance Z for jumper All-copper construction 	Available in standard 0603, 0805, 1206, 2010, and 2512 sizes	<ul style="list-style-type: none"> Automotive controls for body and powertrains Inverter controls for LDC motor drives Instrumentation
WSL 3637 	3 W	55 A	<ul style="list-style-type: none"> 0.001 Ω to 0.01 Ω ± 0.5 % / ± 0.1 % 4-terminal Excellent frequency response to 50 MHz Low TCR resistance NiCr element (< 20 ppm/°C) 	Available in standard 3637 size	<ul style="list-style-type: none"> Automotive controls for body and powertrains Inverter controls for LDC motor drives Instrumentation
WSL Wide terminal 	2 W	52 A	<ul style="list-style-type: none"> 0.00075 Ω to 0.006 Ω Sizes 0612 & 1020 ± 0.5 % / ± 1.0 % / ± 5.0 % High power to footprint size, cooler terminal at same power level 	Available in standard 0612 and 1020 sizes	<ul style="list-style-type: none"> Automotive controls for body and powertrains Inverter controls for LDC motor drives Instrumentation
WSLF3222 	12 W	200 A	<ul style="list-style-type: none"> 0.00015 Ω to 0.0005 Ω ± 1.0 % / ± 5.0 % Very high power 	L = 0.311 in [7.9 mm] W = 0.220 in [5.6 mm] H = see datasheet	<ul style="list-style-type: none"> DC/DC converters in switching power supplies Inverter controls for LDC motor drives Automotive controls for EHPS / EPS / EPaS
WSLF1206 	5 W	129 A	<ul style="list-style-type: none"> 0.0003 Ω to 0.003 Ω ± 1.0 % High power 	Available in standard 1206 size L = 0.32 in [8.1 mm] W = 0.065 in [1.65 mm] H = see datasheet	<ul style="list-style-type: none"> DC/DC converters in switching power supplies Inverter controls for LDC motor drives Automotive controls for EHPS / EPS / EPaS
WSLF 	10 W	183 A	<ul style="list-style-type: none"> 0.0003 Ω to 0.004 Ω ± 1.0 % / ± 5.0 % Low TCR resistance element (< 20 ppm/°C) 	Available in standard 2512 size L = 0.250 in [6.35 mm] W = 0.120 in [3.02 mm] H = 0.045 in [1.14 mm]	<ul style="list-style-type: none"> DC/DC converters in switching power supplies Inverter controls for LDC motor drives Automotive controls for EHPS / EPS / EPaS
WSLP 	3 W	77 A	<ul style="list-style-type: none"> 0.0005 Ω to 0.1 Ω ± 0.5 % / ± 1.0 % Power Metal Strip construction Sulfur resistance Very high power 	Available in standard 0603, 0805, 1206, 2010, and 2512 sizes	<ul style="list-style-type: none"> Automotive controls for body and powertrains Inverter controls for LDC motor drives Instrumentation





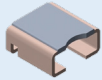
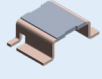
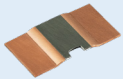
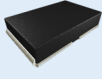
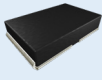



The DNA of tech.®

Product	Power Rating P70 °C	Maximum Current	Features	Dimensions	Applications
WSLP2726 	12 W	245 A	<ul style="list-style-type: none"> 0.0002 Ω to 0.005 Ω, ± 1.0 % 4-terminal Low TCR resistance element (< 20 ppm/°C) 	Available in standard 2726 size L = 0.272 in [6.90 mm] W = 0.260 in [6.60 mm] H = 0.117 in [3.00 mm]	<ul style="list-style-type: none"> DC/DC converters in switching power supplies Instrumentation Automotive controls for EHPS / EPS / EPaS
WSLP4026 	12 W	245 A	<ul style="list-style-type: none"> 0.0002 Ω to 0.005 Ω ± 1.0 % / ± 5.0 % 4-terminal Low TCR resistance element (< 20 ppm/°C) 	Available in standard 4026 size L = 0.400 in [10.10 mm] W = 0.260 in [6.60 mm] H = see datasheet	<ul style="list-style-type: none"> DC/DC converters in switching power supplies Instrumentation Automotive controls for EHPS / EPS / EPaS
WSLP3921 	9 W	300 A	<ul style="list-style-type: none"> 0.0001 Ω to 0.004 Ω ± 1.0 %, ± 5.0 % High power 	Available in standard 3921 size L = 0.394 in [10.0 mm] W = 0.205 in [5.20 mm] H = see datasheet	<ul style="list-style-type: none"> DC/DC converters in switching power supplies Inverter controls for LDC motor drives Automotive controls for EHPS / EPS / EPaS
	WSLP5931	15 W	387 A	<ul style="list-style-type: none"> 0.0001 Ω to 0.003 Ω ± 1.0 %, ± 5.0 % High power 	
WSHM2818 	7 W	84 A	<ul style="list-style-type: none"> 0.001 Ω to 0.2 Ω ± 0.5 % / ± 1.0 % Improved thermal management Low TCR resistance element (< 20 ppm/°C) 	Available in standard 2818 size L = 0.280 in [7.1 mm] W = 0.180 in [4.6 mm] H = 0.059 in [1.5 mm]	<ul style="list-style-type: none"> DC/DC converters in switching power supplies Inverter controls for LDC motor drives Automotive controls for EHPS / EPS / EPaS
WSHP2818 	10 W	100 A	<ul style="list-style-type: none"> 0.001 Ω to 0.010 Ω ± 0.5 % / ± 1.0 % Improved thermal management Low TCR resistance element (< 20 ppm/°C) 	Available in standard 2818 size L = 0.280 in [7.1 mm] W = 0.180 in [4.6 mm] H = 0.059 in [1.5 mm]	<ul style="list-style-type: none"> DC/DC converters in switching power supplies Inverter controls for LDC motor drives Automotive controls for EHPS / EPS / EPaS



The DNA of tech.®

Product	Power Rating P70 °C	Maximum Current	Features	Dimensions	Applications
High-Current, Custom, Power Metal Strip® Resistors					
WSBS5216-14 	12 W	346 A	<ul style="list-style-type: none"> • 100 $\mu\Omega$ • $\pm 5\%$ • 12 W power • Plated terminals 	<ul style="list-style-type: none"> • L = 2.047 in [52.0 mm] • W = 0.630 in [16.0 mm] • H = 0.118 in [3.0 mm] 	<ul style="list-style-type: none"> • Automotive / industrial battery monitor shunts • Power supplies
WSBS8518 	36 W	848 A	<ul style="list-style-type: none"> • 50 $\mu\Omega$, 100$\mu\Omega$, 125 $\mu\Omega$, and 250 $\mu\Omega$ • $\pm 5\%$ • 36 W power 	<ul style="list-style-type: none"> • L = 3.346 in [85.0 mm] • W = 0.708 in [18.0 mm] • H = 0.118 in [3.0 mm] 	
WSBS8518-14 	36 W	848 A	<ul style="list-style-type: none"> • 50 $\mu\Omega$, 100$\mu\Omega$, 125 $\mu\Omega$, and 250 $\mu\Omega$ • $\pm 5\%$ • 36 W power • Plated terminals 	<ul style="list-style-type: none"> • L = 3.346 in [85.0 mm] • W = 0.708 in [18.0 mm] • H = 0.118 in [3.0 mm] 	
WSBS8518-20 	36 W	848 A	<ul style="list-style-type: none"> • 50 $\mu\Omega$, 100$\mu\Omega$, 125 $\mu\Omega$, and 250 $\mu\Omega$ • $\pm 5\%$ • 36 W power • 2 sense pins for increased accuracy 	<ul style="list-style-type: none"> • L = 3.346 in [85.0 mm] • W = 0.708 in [18.0 mm] • H = 0.118 in [3.0 mm] 	
WSBE8518 series 	36 W	1095 A	<ul style="list-style-type: none"> • 30 $\mu\Omega$, 50 $\mu\Omega$, and 100 $\mu\Omega$ • $\pm 5\%$ • 36 W power • 2-pin or 3-pin connector • Low TCR (down to 10 ppm/°C) • Plated terminals optional 	<ul style="list-style-type: none"> • L = 3.346 in [85.0 mm] • W = 0.708 in [18.0 mm] • H = 0.118 in [3.0 mm] 	
WSBE8536 series 	50 W	1825 A	<ul style="list-style-type: none"> • 15 $\mu\Omega$, 25 $\mu\Omega$, and 50 $\mu\Omega$ • $\pm 5\%$ • 50 W power • 2-pin or 3-pin connector • Low TCR (down to 10 ppm/°C) • Plated terminals optional 	<ul style="list-style-type: none"> • L = 3.346 in [85.0 mm] • W = 1.416 in [36.0 mm] • H = 0.118 in [3.0 mm] 	



The DNA of tech.®

Additional Resources:

Power Metal Strip Customization:

http://www.vishay.com/docs/48163/capabilities_and_options_powermetalstrip_vmn-ms7460-1709.pdf

Power Metal Strip Products:

<https://www.vishay.com/resistors-fixed/power-metal-strip/>

Pulse Capability:

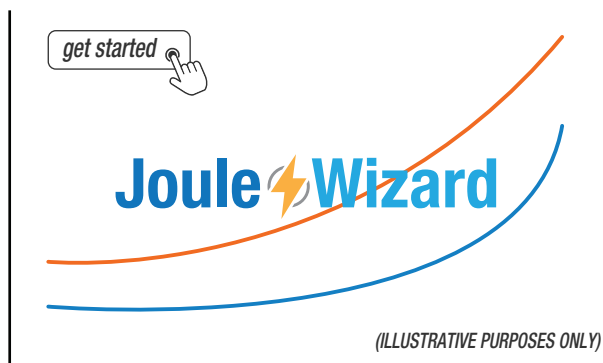

<http://www.vishay.com/en/resistors/joulewizard/>

Selector Guide

Overview of Automotive Grade Products www.vishay.com/doc?49924

Technical Notes

- SMD Current Sense: AEC-Q200 vs. Vishay Qualification www.vishay.com/doc?30416
- MIL-PRF vs. AEC-Q200: Do You Know What You Are Getting? www.vishay.com/doc?11000

White Paper

- Thermal Management for Surface-Mount Devices www.vishay.com/doc?30380
- Temperature Coefficient of Resistance for Current Sensing: www.vishay.com/doc?30405



The DNA of tech.®

Applications

Current sensing Power Metal Strip resistors allow control circuitry to monitor the level of current in a circuit by translating current into a voltage that can be easily measured. The devices work by resisting the current flow in a circuit to a calibrated level, thus allowing a voltage drop to be detected and monitored by control circuitry. The low resistance of Power Metal Strip devices allows this function to be carried out with exceptional accuracy.

Current shunting is another application suitable for the low ohmic Power Metal Strip resistor technology. When shunting, a resistor is used to divert most of the current in an electric circuit. Power shunts are used for electric motor starting, braking, and speed control. Loading, neutral grounding, preheating, and capacitor loading are applications in which a resistor shunts large amounts of current. A two- or four-terminal resistor with low ohmic resistance and high current capability is the best solution for a shunt.

Current sensing and shunting are functions common to all market segments with many applications. Automotive electronics, industrial and medical equipment, mobile telecom, and notebook computers are among the diverse environments in which Power Metal Strip resistors deliver exceptional performance.

Brushless DC Motor Control

The use of brushless DC motors is increasing in motion control applications. The motor's high efficiency and small size are important for automotive, industrial, military, aircraft, and communications equipment.

Automotive engine fan controls utilize brushless DC motors to improve engine temperature management. Accurate air flow and temperature control in the engine compartment are needed to allow the engine to run at a constant higher temperature for better fuel efficiency and lower emissions. The brushless DC motor cools the engine block or radiator to reduce temperature variation while high power current sense resistors are used for fan speed control.

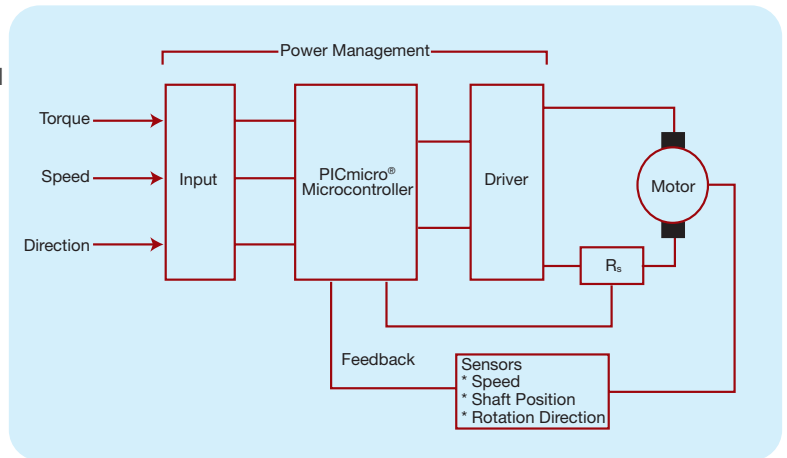

Figure A
(DC Motor Current Monitoring)

Electric power steering and electric vehicle traction drives also use brushless DC motors. A current sense resistor is used to control the peak value of the motor winding current (load current). This is an application that requires low inductance and high current capabilities (see Figure A).

Current sensing resistors are also used in the feedback circuit as replacements for Hall effect sensors. Figure B shows the use of current sense resistor "Rs" in an H-bridge motor control.

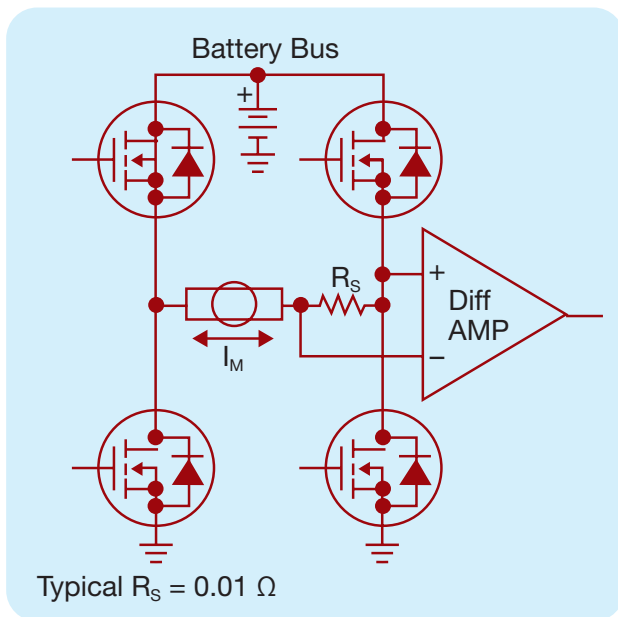

Figure B
(H-Bridge Current Monitoring)

Automotive Battery Management

Accurate current sensing is becoming an increasingly important capability as the demands being placed on automotive batteries are growing. Electrical hydraulic power steering (EHPS) / electric power steering (EPS) / electric power-assisted steering (EPAS), electronic-hydraulic braking, electric and hybrid vehicles, and power doors all require the battery to provide additional current above and beyond what the alternator can deliver. For proper battery management, a low ohmic current sensing resistor is used to sense the amount of current flowing into the vehicle's electrical system. The current sensing resistor must be capable of handling high currents (up to 1000 A) while offering a low temperature coefficient of resistance, low thermal EMF, and high stability in extreme environments. Resistance values of 50 $\mu\Omega$ to 125 $\mu\Omega$ are typically required for these applications. Figure C illustrates the use of a current sense resistor in a high current battery management circuit.

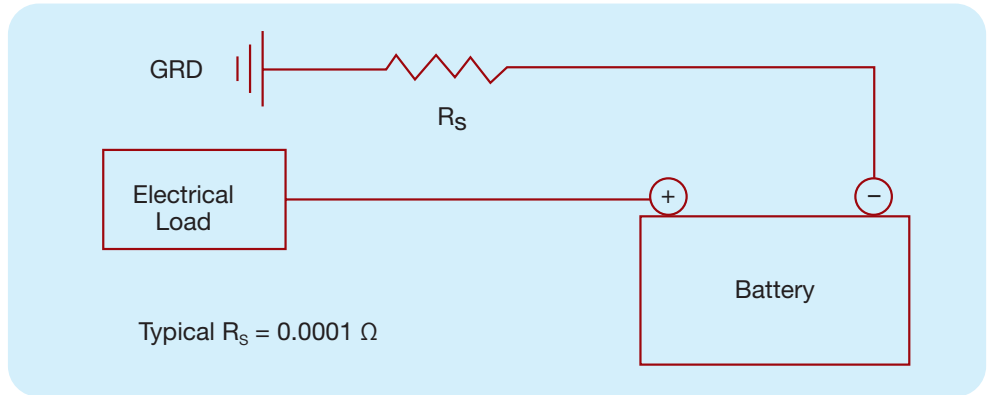

Figure C
(Automotive Battery Sensor)

Utility Power Meters Shunt

The utility industry is seeing a new generation of multifunction power meters. The new meters are more accurate in measuring and reporting actual utility usage and peak usage times, providing the power company with more accurate data to determine customer usage and to adjust billing terms.

In this application, a current sense resistor supports the microcontroller to determine power usage. A current shunt converts the current through the meter to a small, millivolt-level voltage. The voltage across the shunt must remain small to minimize the power dissipation by the shunt. A shunt with a resistance of 100 $\mu\Omega$ will provide a signal of 20 mV and dissipate 1 W of power at 100 A.

Figure D shows the current channel of an electric meter using a current shunt to convert the load current to a millivolt-level voltage.

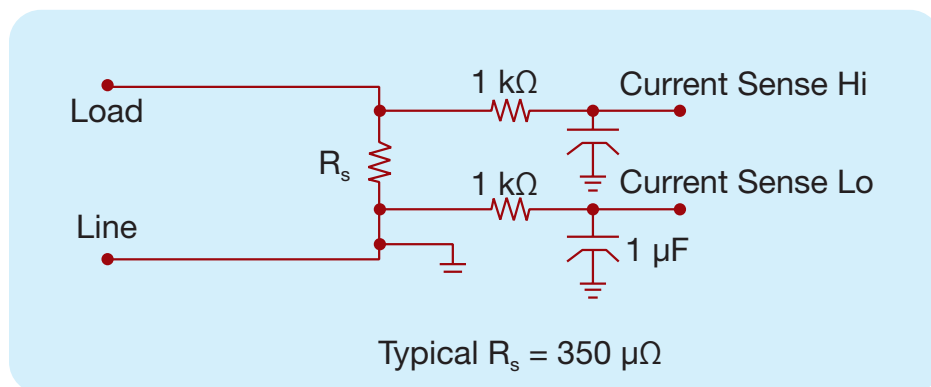

Figure D
(Current Channel of an Electric Meter)